

p 11- simultaneous receivers.
" 10⁸ turn
p 12- 20 year design life
" - stainless

CALTECH/MIT PROJECT
FOR A
LASER INTERFEROMETER
GRAVITATIONAL WAVE
OBSERVATORY

CALIFORNIA INSTITUTE OF TECHNOLOGY
MASSACHUSETTS INSTITUTE OF TECHNOLOGY

December 1987
LIGO-M870001-00-M

100

100

100

100

100

100

100

100

100

100

100

100

100

100

100

100

100

Renewal Proposal
to the
National Science Foundation

**CALTECH/MIT PROJECT
FOR A
LASER INTERFEROMETER
GRAVITATIONAL WAVE OBSERVATORY**

Rochus E. Vogt
Principal Investigator and Project Director
California Institute of Technology

Ronald W. P. Drever
Co-investigator
California Institute of Technology

Kip S. Thorne
Co-investigator
California Institute of Technology

Rainer Weiss
Co-investigator
Massachusetts Institute of Technology

100-100000-100000

100-100000-100000

100-100000-100000

100-100000-100000

100-100000-100000

100-100000-100000

100-100000-100000

100-100000-100000

100-100000-100000

100-100000-100000

100-100000-100000

100-100000-100000

100-100000-100000

100-100000-100000

100-100000-100000

100-100000-100000

100-100000-100000

100-100000-100000

100-100000-100000

100-100000-100000

100-100000-100000

100-100000-100000

100-100000-100000

100-100000-100000

100-100000-100000

100-100000-100000

100-100000-100000

100-100000-100000

100-100000-100000

SIX

100-100000-100000

100-100000-100000

100-100000-100000

100-100000-100000

100-100000-100000

COVER SHEET FOR PROPOSALS TO THE NATIONAL SCIENCE FOUNDATION

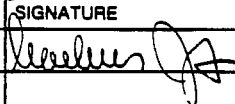
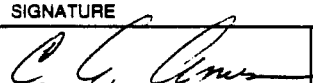
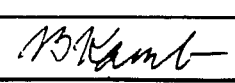
FOR CONSIDERATION BY NSF ORGANIZATIONAL UNIT <small>(Indicate the most specific unit known, i.e. program, division, etc.)</small>		PROGRAM ANNOUNCEMENT/SOLICITATION NO./CLOSING DATE	
Gravitational Physics/Division of Physics			
SUBMITTING INSTITUTION CODE <small>(If known)</small>	FOR RENEWAL <input checked="" type="checkbox"/> CONTINUING AWARD <input checked="" type="checkbox"/> ACCOMPLISHMENT BASED RENEWAL <input type="checkbox"/> REQUEST. LIST PREVIOUS AWARD NO.:	IS THIS PROPOSAL BEING SUBMITTED TO ANOTHER FEDERAL AGENCY? Yes ___ No <u>X</u> IF YES, LIST ACRONYM(S)	
	PHY-8504136		
NAME OF SUBMITTING ORGANIZATION TO WHICH AWARD SHOULD BE MADE (INCLUDE BRANCH/CAMPUS/OTHER COMPONENTS)			
California Institute of Technology			
ADDRESS OF ORGANIZATION (INCLUDE ZIP CODE)			
Pasadena, CA 91125			
IS SUBMITTING ORGANIZATION: <input type="checkbox"/> For-Profit Organization; <input type="checkbox"/> Small Business; <input type="checkbox"/> Minority Business; <input type="checkbox"/> Woman-Owned Business			
TITLE OF PROPOSED PROJECT			
Caltech/MIT Project for a Laser Interferometer Gravitational Wave Observatory			
REQUESTED AMOUNT	PROPOSED DURATION	DESIRED STARTING DATE	
\$18,118,396	Three (3) Years	1 June 1988	
CHECK APPROPRIATE BOX(ES) IF THIS PROPOSAL INCLUDES ANY OF THE ITEMS LISTED BELOW:			
<input type="checkbox"/> Animal Welfare <input type="checkbox"/> National Environmental Policy Act <input type="checkbox"/> International Cooperative Activity <input type="checkbox"/> Endangered Species <input type="checkbox"/> Research Involving Recombinant DNA Molecules <input type="checkbox"/> Research Opportunity Award <input type="checkbox"/> Human Subjects <input type="checkbox"/> Historical Sites <input type="checkbox"/> Facilitation Award for Handicapped <input type="checkbox"/> Marine Mammal Protection <input type="checkbox"/> Interdisciplinary <input type="checkbox"/> Proprietary and Privileged Information <input type="checkbox"/> Pollution Control			
PI/PD DEPARTMENT	PI/PD ORGANIZATION	PI/PD PHONE NO. & ELECTRONIC MAIL	
Division of Physics, Mathematics & Astronomy	California Institute of Technology	(818)-356-3800 vogt@caltech.edu	
PI/PD NAME/TITLE	SOCIAL SECURITY NO.*	HIGHEST DEGREE & YEAR	SIGNATURE
Director, LIGO; Rochus E. Vogt Prof. of Physics	345-30-2172	Ph. D. - 1961	
ADDITIONAL PI/PD (TYPED)			
ADDITIONAL PI/PD (TYPED)			
ADDITIONAL PI/PD (TYPED)			
ADDITIONAL PI/PD (TYPED)			
For NSF Use:			
AUTHORIZED ORGANIZATIONAL REP.	SIGNATURE	DATE	TELEPHONE NO.
NAME/TITLE (TYPED) C. A. Ames Deputy Deputy Director of Finance/ Controller		12/14/87	818-356-6712
OTHER ENDORSEMENT (optional)			
NAME/TITLE (TYPED) W. Barclay Kamb Vice President and Provost		14 Dec 87	(818)-356-6336

*Submission of social security numbers is voluntary and will not affect the organization's eligibility for an award. However, they are an integral part of the NSF information system and assist in processing the proposal. SSN solicited under NSF Act of 1950, as amended.

Table of Contents

PROJECT SUMMARY	1
I. INTRODUCTION	2
II. SCIENCE	4
A. The Physics of Gravitational Waves and Interferometric Detectors	4
B. Scientific Payoff from the LIGO Project	6
C. Estimates of the Strengths of the Waves at Earth and Comparison with Anticipated LIGO Sensitivities	6
D. Other Methods of Detecting Gravitational Waves	8
III. HISTORY OF THE PROJECT	9
IV. LIGO CONCEPT AND LONG-RANGE PLANS	11
A. Essential Features of the LIGO	11
B. Plans and Schedules for the Entire LIGO Project	12
V. RESULTS FROM PRIOR NSF SUPPORT	14
A. Prototype Receivers	15
B. Development of Capabilities for LIGO Receivers	25
C. LIGO: Large Baseline System Development	30
D. Collaborative Efforts	32
E. Recent Bibliography	34
F. Relation of Completed to Proposed Work	36
VI. PROPOSED WORK	37
A. Receiver Development	37
B. Buildup of Experimental Facilities	51
C. Conceptual Design for the LIGO	53
D. Sites	53
E. Vacuum Prototype	53
F. Preliminary Engineering Design and Cost Definition	54
G. Proposal for Construction	56
VII. ORGANIZATION AND MANAGEMENT	58
VIII. BUDGET	63
Discussion and Residual Funds Statement	63
Level-of-Effort Summary Tables	65
Proposal Budget in NSF Format	69
Budget Explanation Pages	73
Current and Pending Support	82
IX. REFERENCES	
X. VITAE	
XI. PUBLICATIONS	
APPENDIX A, THE PHYSICS OF GRAVITATIONAL WAVES, AND COMPARISON OF SOURCE STRENGTHS WITH DETECTOR SENSITIVITIES	
APPENDIX B, LIGO CONCEPT	
APPENDIX C, NATIONAL AND INTERNATIONAL COOPERATION	
APPENDIX D, SUMMARY OF NOVEMBER 1986 NSF REVIEW	
APPENDIX E, OTHER PROGRAMS IN GRAVITY-WAVE OBSERVATIONS	
APPENDIX F, PRELIMINARY DESIGN OF A LIGO FABRY-PEROT RECEIVER	
APPENDIX G, PRELIMINARY DESIGN OF A LIGO DELAY-LINE RECEIVER	
APPENDIX H, TECHNICAL DETAILS OF THE PROTOTYPE INTERFEROMETERS	
APPENDIX I, DATA ANALYSIS DEVELOPMENT	
APPENDIX J, OTHER LIGO EXPERIMENTS AND TECHNOLOGY APPLICATIONS	

I. INTRODUCTION

Laser interferometer gravity wave receivers have been developed to the stage where it is possible to design full-scale instruments with sensitivities in the range of anticipated astrophysical signals. This proposal requests support for a three year program of research and development towards the establishment of a laser interferometer gravitational wave observatory (LIGO). The research and development activities leading up to this proposal were accomplished under separate NSF grants, with R. W. P. Drever (Caltech) and R. Weiss (M.I.T.) serving as Principal Investigators, respectively. Work since September 1987 has been performed with R. E. Vogt serving as Project Director, and R. W. P. Drever and R. Weiss acting as leaders of their respective science teams. Future operations under the new management structure are discussed in Part VII.

Important scientific results in the areas of basic physics and in astronomy and astrophysics are expected from the LIGO. Theoretical astrophysics now gives estimates of the strength of waves from supernovae and other stellar collapses to neutron stars, stellar implosions that form black holes, pulsars, coalescing neutron-star or black-hole binaries, rotating neutron stars, gravitational-spindown neutron stars, and other burst, periodic, and stochastic sources. These estimates indicate that there is a significant, though not high, chance that waves will be detected with the initial LIGO receivers. Detection is highly probable at the sensitivities of expected advanced receivers.

The LIGO project, a joint undertaking of the California Institute of Technology and the Massachusetts Institute of Technology, is based on more than a decade of research and development of laser interferometer gravitational wave receivers.

The National Science Foundation has supported Caltech and MIT for a number of years in their research on interferometric receivers and in their initial design studies of a LIGO. Funds from this proposal will carry these designs to the point where an accurate cost estimate can be made. This will lead in 1989 to a proposal to the NSF for the final engineering design and construction.

Receiver development during the next three years will be directed toward a design for the full-scale system. Higher sensitivity and extended frequency coverage will be pursued. In addition, the engineering of components and controls for the reliable operation required in the LIGO will begin. Fabrication and tests of large mirrors and analyses and tests of other features required for the full-sized system will be conducted. The conceptual design of the LIGO will be completed and functional requirements defined. These will form the basis for a Preliminary Engineering Design and Cost Definition of the LIGO vacuum facilities, the architectural and civil engineering work at specific sites, the receivers, and the data and instrumentation systems. This work will be done by an engineering firm. The design and cost estimate from this contracted work will then be used in the proposal for construction of the LIGO.

The LIGO will consist of a pair of cross-correlated receivers located far apart within the continental United States and housed in L-shaped vacuum systems; the arms of each system will be about 4 kilometers in length (Figure I-1). The two receivers, together with their electronics and data analysis system, make up a gravitational wave "detector." Cross-correlation of receivers at two sites will secure the identification of gravity waves.

PROJECT SUMMARY

This proposal requests support for a three year program of research and development towards the establishment of a laser interferometer gravitational wave observatory (LIGO) with sensitivities in the domain of theoretical expectations for gravity waves. This joint undertaking of the California Institute of Technology and the Massachusetts Institute of Technology is based on more than a decade of research and development of laser interferometer gravitational wave receivers. We propose to continue research and development of gravity wave receivers towards ever higher sensitivities and towards the design of operational full scale LIGO receivers. We will continue feasibility demonstrations and tests of critical components for the LIGO. We will complete the conceptual design of the LIGO, consisting of L-shaped interferometer receiver systems with 4 km sides at two cross correlated sites. We will undertake a Preliminary Design and Cost Definition task, leading to a proposal to NSF in 1989 for construction of the LIGO. The ultimate objectives of the LIGO program include (i) tests of Einstein's General Theory of Relativity, in particular, measurements of the graviton rest mass and spin, tests of general relativity in the domain of highly non-linear, dynamic gravity, and (ii) the opening of a window to the universe radically different from electromagnetic, cosmic-ray, or neutrino astronomy.

II. SCIENCE

This section presents in brief the scientific justification and goals of the LIGO Project. For greater detail on these issues and for references to the literature see Appendix A.

A. The Physics of Gravitational Waves and Interferometric Detectors

Gravitational waves are predicted by general relativity theory and by all other relativistic theories of gravity, and all the theories agree, in rough order of magnitude, on the strengths of the waves to be expected from astrophysical sources. However, the theories disagree on a wave's propagation speed (from which one can infer the rest mass of the graviton) and on its polarization properties (from which one can infer the graviton's spin). In general relativity the propagation speed is the same as light (the graviton has zero rest mass), and the wave's force field is transverse to its propagation direction and has quadrupolar symmetry (the graviton has spin two). The two polarization states of general relativity's wave are called + ("plus") and × ("cross") and are characterized by two dimensionless fields h_+ and h_\times .

A *laser interferometer gravitational wave receiver* ("interferometric receiver"; also called an "antenna"), in its simplest conceptual variant, consists of three masses that hang by wires from overhead supports at the corner and ends of an "L" (Figure II-1a). A gravitational wave pushes the masses back and forth relative to each other, changing the difference $L_x - L_y$ in the length of the receiver's two arms by an amount ΔL that is proportional to arm length, L , and to a linear combination of h_+ and h_\times :

$$\frac{\Delta L}{L} = [1/2(1 + \cos^2 \theta) \cos 2\phi]h_+ + [\cos \theta \sin 2\phi]h_\times \equiv h. \quad (1)$$

Here (θ, ϕ) is the wave's propagation direction. By laser interferometry one directly reads out $\Delta L/L$ and from its time evolution, the combination, called h , of $h_+(t)$ and $h_\times(t)$ in equation (1).

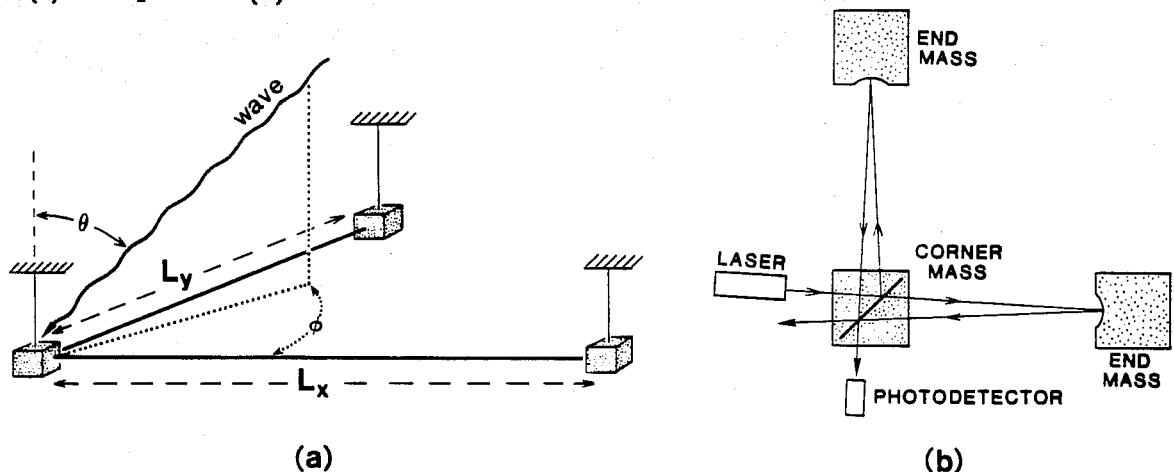

Figure II-1 Schematic diagram of a laser interferometer gravitational wave detector.

Laser interferometry in its simplest theoretical variant is performed as follows: Light from a laser shines on a beamsplitting mirror that rides on the central mass (Figure II-1b). The beam splitter directs half the light toward each of the two end masses,

The "observatory", consisting of the receivers and facilities at both sites, shall be under one management to optimize design tradeoffs, provide for simultaneous start-up, and assure a high live time. The LIGO will be designed as a facility with expandability to support multiple detectors of ever-increasing sensitivity as receiver technology develops.

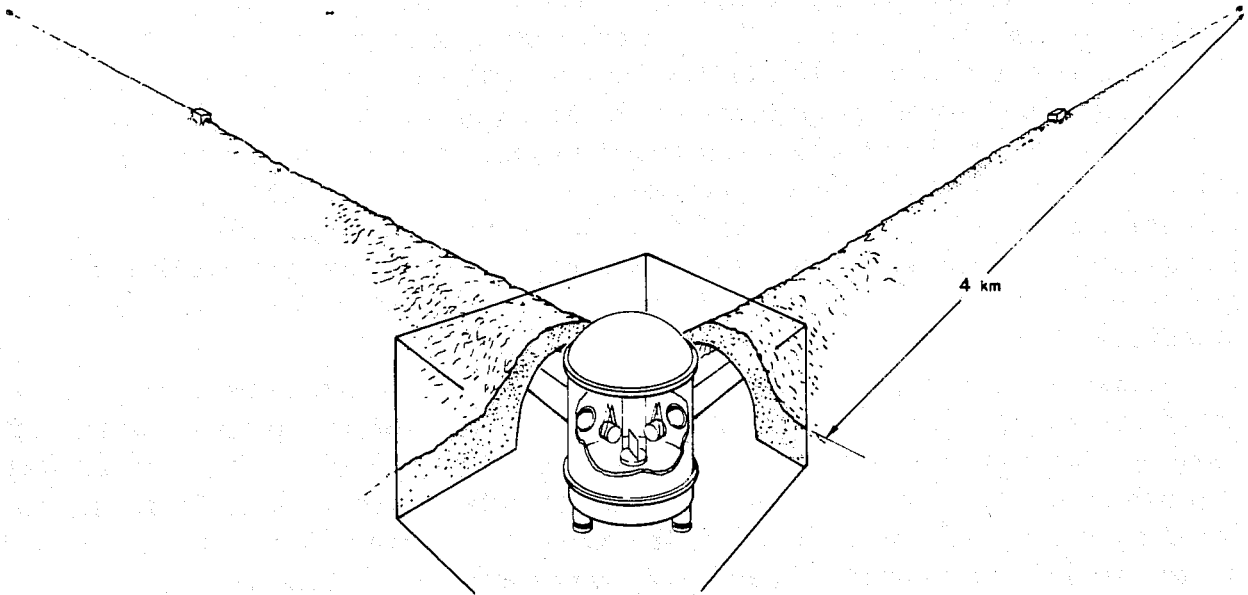

Figure I-1 Artist's conception of a LIGO receiver installed at one of the two sites.

The LIGO facilities will accommodate gravitational wave searches and receiver development concurrently. After shakedown, the LIGO will be used in a national program for gravitational astronomy, open to all qualified participants. It is expected that a world-wide network of gravitational wave detectors will eventually be built up around the LIGO. Such a network, not unlike the VLBA in radio astronomy, will be necessary for extraction of the full information carried by gravitational waves.

carried by electromagnetic; and our present electromagnetically-based understanding of the universe is inadequate to predict with confidence the strengths of the gravitational waves bathing the earth. Obversely, if gravitational waves can be detected and studied, they may create a revolution in our view of the universe comparable to that wrought by radio astronomy.

B. Scientific Payoff from the LIGO Project

From the above discussion and the further details in Appendix A we cull the following list of scientific payoffs that might come from the LIGO Project. The Project is being designed and managed, so far as possible, in such a way as to maximize the likelihood that some or most of these payoffs will be achieved.

Possible Payoffs for Physics

- The verification of the existence of gravitational waves.
- Measurement of the rest mass and spin of the graviton: do they agree with general relativity's predictions, $m = 0$ and $s = 2$?
- Verification (by comparing theoretical and observed wave forms) that black holes exist and that their dynamics are as predicted by general relativity. Thereby test general relativity for the first time in the domain of highly nonlinear, dynamic gravity.

Some Possible Payoffs for Astronomy and Astrophysics

- Open up a new window onto the universe, a window that is almost certain to bring surprises and that may bring a revolution comparable to that which came from the radio window in the 1950s and 60s.
- Study the behavior of neutron stars in highly dynamical situations. Thereby extract information about the uncertain physics that governs neutron stars.
- Use the waves from binary coalescences as "standard candles" for the determination of the Hubble expansion rate and deceleration parameter of the universe (see App. A).
- Detect primordial gravitational waves from the big bang, and from them extract information about the initial conditions and earliest stages of evolution of the universe.

C. Estimates of the Strengths of the Waves at Earth and Comparison with Anticipated LIGO Sensitivities.

Whether these payoffs can be achieved will depend on whether detectors in the LIGO can reach the required sensitivities. Figure II-2 gives some indication of the prospects for this by comparing the wave strengths from various hypothesized burst sources with several benchmarks for detector sensitivity. (For the details underlying Figure II-2, and for similar figures for periodic and stochastic waves, see Appendix A.)

The most certain of the sources is coalescence of neutron-star binaries: Estimates based on pulsar statistics in our own galaxy suggest that to see 3 such events per year one should look out to 100_{-40}^{+100} Mpc distance. (See Appendix A for further details on this and all sources). For supernovae the event rate is known to be roughly one each 40 years in our own galaxy and several per year in Virgo, but the amount of radiation

and mirrors on those masses return beams to the splitter where they are recombined. The gravity-wave-induced change ΔL in the arm length difference produces a relative phase shift in the recombining beams, and thence a shift in how much of the light goes into the photodetector of Figure II-1b versus how much goes back toward the laser. The photodetector output therefore varies in direct proportion to ΔL and thus proportionally to the combination of $h_+(t)$ and $h_\times(t)$ appearing in equation (1). In realistic variants of such a detector (Part V and Appendices F, G, H, below), the ΔL -induced phase shift is increased by placing mirrors on the corner mass as well as the ends, and then bouncing the light back and forth many times in each arm (“delay-line interferometric receiver”) or operating each arm as a giant Fabry-Perot cavity (“Fabry-Perot interferometric receiver”).

Since ΔL is proportional to L , the longer are the arms L , the greater will be the relative phase shift for the beams that propagate down the arms, and the more sensitive will be this interferometric receiver. That is why we are planning to upgrade from our present prototype receivers with $L \leq 40$ meters to a full-scale LIGO with $L = 4$ kilometers.

By cross correlating the outputs of several receivers with different orientations and different locations on earth, i.e., by using them as a single detector, one can read out the full information carried by the wave: the direction (θ, ϕ) of its source and the time evolution of its two *wave forms* $h_+(t)$ and $h_\times(t)$. One can also read out the spatial pattern of the forces that act on the detector’s masses and from it infer the wave’s polarization properties and thence the graviton’s spin. If the wave’s source is also seen with electromagnetic telescopes (optical, radio, X-ray, ...), e.g. if it is a supernova, then by measuring the delay between the electromagnetic and gravitational signals one can determine whether photons and gravitons propagate at the same speed and thus have zero rest mass.

The gravitational wave forms $h_+(t)$ and $h_\times(t)$ carry detailed information about their sources; and because the strongest sources in the LIGO’s huge frequency band ($10 \text{ Hz} \lesssim f \lesssim 10^4 \text{ Hz}$) are likely to be neutron stars and black holes, the wave forms can bring us detailed information about the dynamical behaviors of these objects in violent events such as their births and collisions; cf. Figure A-3 in Appendix A. A stochastic background of gravitational waves from the big bang could bring us detailed information about the earliest moments of the universe; and coalescing, compact binary stars could act as standard candles for measuring the large-scale structure of the universe today; see Appendix A for details.

Gravitational and electromagnetic waves differ greatly: Gravitational waves should be emitted by coherent bulk motions of matter (e.g. collapsing stellar cores) and coherent, nonlinear vibrations of spacetime curvature (e.g. collisions of black holes). By contrast, astronomical electromagnetic waves are usually incoherent superpositions of emission from individual atoms, molecules, and charged particles. Gravitational waves are emitted most strongly in regions of spacetime where gravity is relativistically strong, whereas electromagnetic waves come almost entirely from weak-gravity regions, since strong-gravity regions tend to be obscured by surrounding matter. Because of these differences, the information carried by gravitational waves is almost “orthogonal” to that

D. Other Methods of Detecting Gravitational Waves

The above discussion provides a basis for comparing the LIGO project with other methods of detecting gravitational waves (for a more detailed comparison and for references to the literature see Appendix E):

There is a rich potential for gravitational wave astronomy at frequencies below the LIGO's 10 Hz cutoff; but such frequencies probably cannot be reached with earth-based detectors. The best long-term promise in this band lies with interferometric detectors in space, which will rely in considerable measure on experience with the LIGO.

In the LIGO's frequency band, earth-based bar detectors have been under development since the early 1960s, a decade longer than interferometric detectors. Room temperature bars achieved an h -sensitivity for bursts of 3×10^{-17} in the mid 1970s (before the Caltech and MIT interferometric efforts began); and by cooling to 4K, they (Stanford and Rome/CERN) are now at 1×10^{-18} , a factor 3 better than our present 40-meter prototype. For the foreseeable future, bars will remain an important component of the world's gravitational wave research effort and they may well improve into the vicinity of 10^{-20} , adequate for detection of rare events in our own galaxy or the Magellanic clouds, but inadequate for extragalactic astronomy, the realm of large event rates.

Bar detectors cannot be lengthened to kilometer scales, with an accompanying large sensitivity improvement (recall: $\Delta L \sim hL$), because they rely on sound waves (speed ~ 1 meter per millisecond) for coupling their two ends, rather than light (speed 300 kilometers per millisecond). As a result, it is unlikely they will reach the LIGO's projected sensitivity region, $\sim 10^{-21}$ to $\sim 10^{-23}$ (the realm of extragalactic astronomy); cf. Figure II-2. Also, bar detectors have difficulty achieving large band width, and correspondingly can extract only limited information from any waves they discover. At present their bandwidths are $\Delta f/f \sim 0.01$ at $f \simeq 900$ Hz, and there is hope in the future of reaching $\Delta f/f \sim 0.2$. By contrast, the present prototype interferometers have $f_{\max}/f_{\min} \sim 10$, and the LIGO is projected to have $f_{\max}/f_{\min} \sim 1000$ (figure II-2) — adequate for essentially full information extraction.

emitted is very uncertain. For black hole births, both the wave-emission efficiency and the distance to which one must look are highly uncertain.

The upper solid curve and stippled region in Figure II-2 indicate the present sensitivity of our 40-meter prototype. The middle thick curve and stippling indicate the sensitivity of an early detector that might operate in the LIGO (see Equation A.21, Appendix A).

Once the first detector has been operated near the sensitivity of the middle curve, there will follow in the LIGO a succession of ever improving detectors, continually pushing the sensitivity level downward (to smaller h) and leftward (to lower frequencies f). As a rough measure of where this might lead after a few years, we have drawn a lower sensitivity region corresponding to a "Possible Advanced Detector" (see Equation A.23, Appendix A). The only limit of principle on detector sensitivities in the LIGO is the "quantum limit" (dashed line)—and with cleverness, ways of circumventing it might be found.

By comparing the source strengths and benchmark sensitivities in Figure II-2 and in the periodic and stochastic figures A-4b,c (Appendix A), one sees that (i) *There are nonnegligible possibilities for wave detection with the first detector in the LIGO.* (ii) *Detection is probable at the sensitivity level of the advanced detector.* (iii) *The first detection is most likely to occur, not in the initial detector in the LIGO but rather in a subsequent one, as the sensitivity and frequency are being pushed downward from the middle curve toward the bottom curve of Figure II-2.*

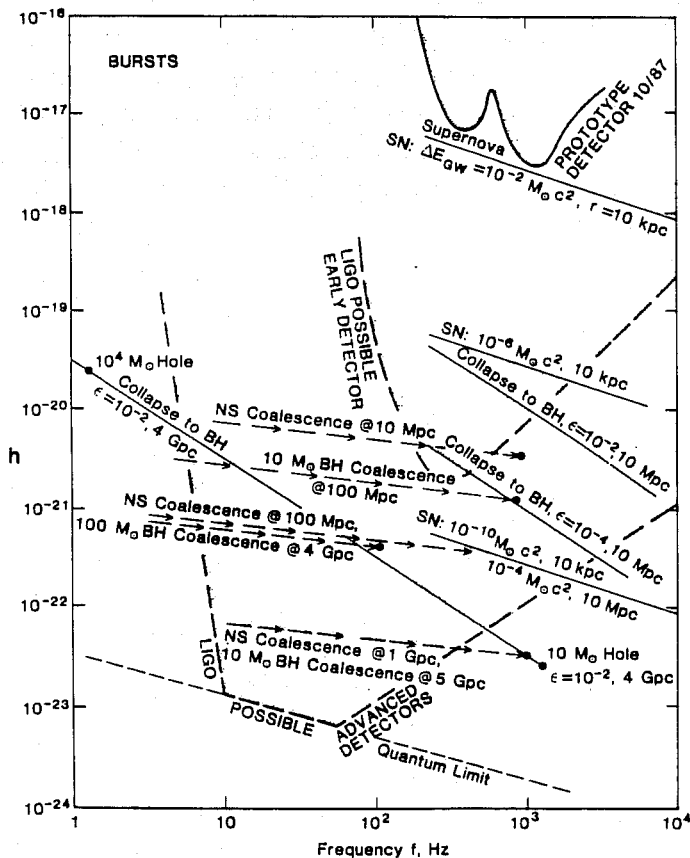

Figure II-2 The estimated wave strengths for various sources of gravitational-wave bursts (thin solid curves and arrows); and benchmark sensitivities for interferometric detectors today and in the proposed LIGO (thick curves and stippling above them). For analogous figures on periodic and stochastic gravitational waves and for the details underlying this figure see Appendix A. Abbreviations: SN—supernova; NS—neutron star; BH—black hole; $M_{\odot} c^2$ —one solar rest mass (units for energy carried by the waves); ϵ —the fraction of the mass of a black hole emitted in the waves. The assumed distances to the sources include 10 kpc—10 kiloparsecs (center of our galaxy); 10 Mpc—10 megaparsecs (Virgo cluster of galaxies); 4 Gpc—4 gigaparsecs (the edge of the observable universe). For each detector the bottom curve is the sensitivity at unity signal-to-noise for a wave with optimal direction and polarisation (the conditions under which detector sensitivity is normally quoted); and the top of the stippled region is the sensitivity for 90% confidence of detection of very rare events, e.g., once per month or year, with random source direction and polarisation.

III. HISTORY OF THE PROJECT

The LIGO project is based upon a significant body of research and technical development over a period of almost 30 years.

After Weber's pioneering work on bar detectors for gravitational waves in the 1960's [III-1], other groups began to develop gravity-wave detectors. In the late 60's, the idea of interferometric detectors was conceived independently by Weber, Weiss, and others. The basic design for a delay line variant of an interferometric receiver was described and the dominant noise sources were quantified in 1972 by Weiss [III-2]. The first operation of an interferometric receiver was conducted by Moss, Miller, and Forward in 1971-72 [III-3].

In the early 1970's, many groups, including Drever at Glasgow and others at Stanford, LSU, IBM, Bell Labs, Rochester, Munich, Rome, and Moscow began research with bar detectors. Several of these groups have continued a strong program of research with successive detectors. A switch from bar detectors to interferometers was made by the Munich group under Billing in 1975 and the Glasgow group under Drever in 1977. A year later, Drever at Glasgow introduced the concept of the Fabry-Perot variant of an interferometric receiver [III-4].

In 1979 Drever started experimental gravity-wave research at Caltech. In the same year the National Science Foundation convened the Deslattes Committee which recommended strong funding of the gravity-wave field, including new interferometer projects at Caltech (Drever) and at MIT (Weiss). MIT pursued a delay-line or Michelson interferometer development, while Drever continued development of Fabry-Perot receivers.

In 1981, Weiss at MIT, with the firms of Stone & Webster and A.D. Little, began a detailed study of the design and costs of a large-scale Laser Interferometer Gravitational-wave Observatory, or LIGO [III-5]. A presentation by Drever, Thorne, and Weiss in 1983 to the NSF Advisory Committee for Physics led to its strong endorsement of the LIGO concept. In 1984, Caltech and MIT formally joined in a project for the design, construction and operation of the LIGO facility, under Drever, Thorne, and Weiss as a steering committee. In the same year the National Science Board approved project planning and feasibility studies. Further studies of design and cost were undertaken with the Caltech Jet Propulsion Laboratory in this period.

In 1986, the NAS Physics Survey strongly endorsed the LIGO for ground-based research in gravity [III-6]. Concurrently, the International Society of General Relativity and Gravitation strongly endorsed the LIGO.

In November, 1986 an NSF sponsored Workshop was convened at Cambridge, Massachusetts to review the state of developments in the field with particular attention to plans for the LIGO Project. The Workshop was attended by 55 international participants and a report of the meeting was prepared by an eight-member panel from disciplines other than experimental gravity. The report was highly supportive of the program and endorsed a vigorous pursuit of its goals. The Summary of this January, 1987 report to the NSF by the Panel on Interferometric Observatories for Gravitational Waves is included in this proposal in Appendix D. Two recommendations of the Panel have already been implemented: management of the project has been transferred from the steering committee to a Project Director, Rochus E. Vogt, and a choice has been made of the type of receiver (Fabry-Perot) to be used in the initial operations with the LIGO.

7. *A minimum lifetime of the facilities of 20 years.* Since the facilities will become a working physics laboratory and astronomical observatory with a rich spectrum of investigations, we must plan for a long life. Experience in other fields suggests 20 years as a reasonable minimum. In its mature phase (after the early gravitational-wave searches) the LIGO will be operated by Caltech and MIT as a facility open to investigations by experimenters from other institutions, capable of supporting several simultaneous investigations (see the discussion of national and international cooperation in Appendix C).

8. *Adequate support instrumentation.*

These essential features are incorporated into the conceptual design of the LIGO, currently under development. That design includes: (i) a selection of sites based on scientific, geophysical, and logistic considerations (the tentatively chosen sites are Edwards AFB, California and Columbia, Maine); (ii) stainless steel vacuum tubes and instrumentation chambers; (iii) enclosure of the vacuum tubes in a housing (e.g., a culvert) and insulation with an earthen berm. For details see Appendix B.

B. Plans and Schedules for the Entire LIGO Project

The LIGO Project will be accomplished in three phases: (i) completion of the conceptual design, the subject of current activity; (ii) a preliminary engineering design and cost definition phase to be supported by an industrial contractor, the subject of this proposal; and (iii) a detailed engineering design and construction phase, to be the subject of a future proposal. Our schedule is shown in Figure IV-1.

The current phase, completion of the conceptual design, will proceed while this proposal is being considered by the National Science Foundation. It is based largely on an earlier feasibility study by MIT/A. D. Little/Stone & Webster, and subsequent trade-off studies supported by the Caltech Jet Propulsion Laboratory. The focus of this activity, described in more detail in Part VI of this proposal, will be to complete the design requirements and baseline definition of the LIGO facilities, to complete those site studies necessary to support the preliminary engineering design (including final selection of primary and backup sites), and to prepare a Request for Proposal for the Preliminary Engineering Design and Cost Definition effort. These activities should be complete by the end of June, 1988.

Upon NSF's approval of funding for the second phase (this proposal) and completion of our preparations, we will solicit competitive proposals for a Preliminary Engineering Design and Cost Definition of the LIGO facilities. This will result in a negotiated Fixed Price Level-of-Effort contract with an experienced architectural and engineering firm to perform engineering design to the level of detail necessary to produce a reliable estimate of the costs of the LIGO facilities (see Part VI). The results of this intensive nine month effort will lead to the preparation of a proposal to the National Science Foundation for the construction the LIGO, which we expect to submit in September, 1989. During the six month interval required for NSF review of the construction proposal, we will complete preparations for the procurement and implementation of contracts for the final engineering design data (construction documents) and construction activities. NSF's final approval for the LIGO is expected in Spring 1990 on the basis of the construction proposal.

IV. LIGO CONCEPT AND LONG-RANGE PLANS

A. Essential Features of the LIGO

The LIGO design will be guided by two goals: (i) maximizing the probability of detecting gravitational waves; and (ii) extracting maximum information from the waves. These goals dictate the following essential features of the LIGO design. (Here we justify each feature only briefly; for more detail see Appendix B).

1. *Two widely separated sites under common management.* The unequivocal detection of gravitational wave bursts amidst instrumental and environmental noise requires cross correlation of two receivers at widely separated sites. Common management is essential to guarantee that two receivers of nearly equal sensitivity are on line simultaneously at two sites, with a high live time.

2. *Arm lengths of order 4 kilometers at each site.* A high probability of discovering waves (e.g., a high confidence of reaching the most reliably understood source, neutron-star binaries in distant galaxies) requires sensitivities near those of the "possible advanced detectors" of Figure II-2. Such sensitivities can be achieved only with arm lengths of the order $L \approx 4$ km. Because event rates scale as (h -sensitivity)⁻³, a reduction of L to 1 km, for example, would reduce by 64 the event rate and substantially reduce the probability of detection.

3. *The ability to operate simultaneously several receiver systems at each site.* The operation of successive generations of continually improving receivers in the LIGO, pushing downward toward the "advanced detector levels" of Figure II-2, will require the ability to develop new, more advanced receiver pairs simultaneously with gravity-wave searches by the best existing receiver pair. This will be possible only if each site can support several systems simultaneously, with a minimum of mutual interference.

4. *The capability for receivers of two different arm lengths.* The rate of spurious, instrumentally and environmentally induced events at each site may be so high that extensive local vetoes are needed in addition to cross correlation between sites. Simultaneous operation of a 2 km and a 4 km receiver at each site provides a powerful veto, since real events must have signals proportional to arm length. Dual arm lengths will also be important for diagnostic studies of local noise.

5. *A vacuum tube diameter of order 48 inches.* Several prospective optical configurations involve a large number of optical beams simultaneously occupying the vacuum tube. (Examples: (i) a single delay-line receiver; (ii) a 2-km, 4-km Fabry-Perot pair with additional beams used in antiseismic isolation, operating simultaneously with a more advanced receiver system under development.) A diameter of 48 inches is required by such configurations to make negligible the scattering of light from one beam into another and negligible diffraction and scattering by the tube walls.

6. *The capability of a vacuum level of 10^{-8} torr.* Fluctuations in the index of refraction of residual gas produce wave-imitating fluctuations in the light beams' phase delays. To keep this noise negligible requires for the first LIGO receivers a vacuum of only 10^{-3} torr of hydrogen or 10^{-4} torr of air; but "advanced" receivers (Figure II-2) will require 10^{-8} torr.

LIGO PROJECT SCHEDULE

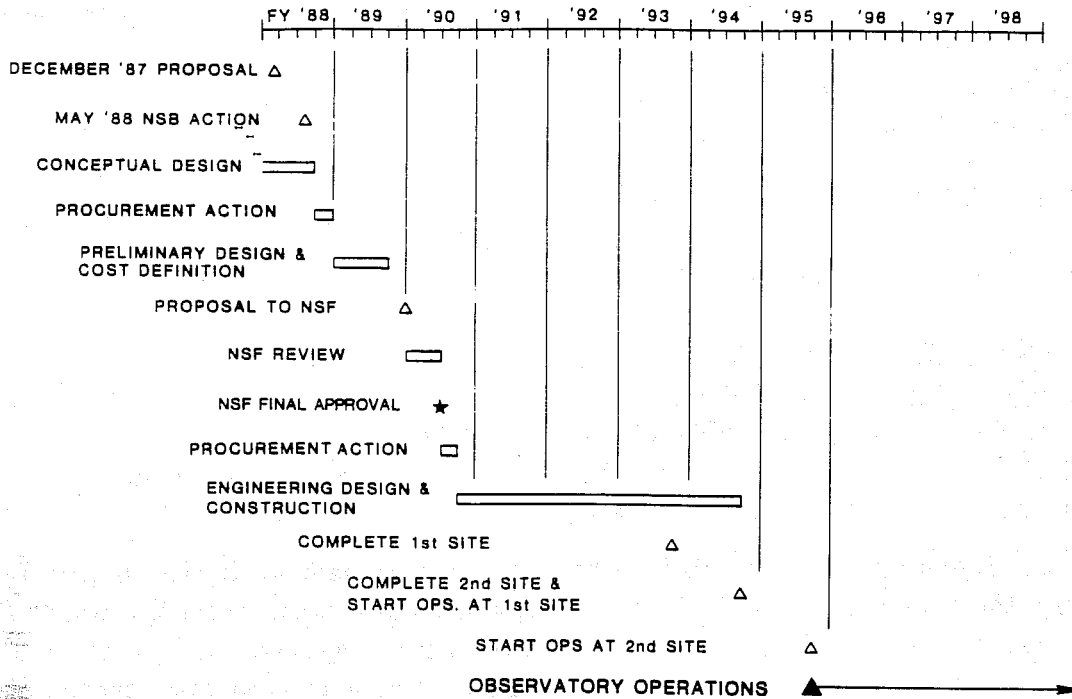

Figure IV-1 Schedule for the LIGO Project

The final engineering design and construction phase is a four year effort planned to begin in Summer 1990. Activities in the first year will concentrate on completion of detailed engineering design documentation, consisting of architectural drawings, specifications, detailed construction schedules and other construction documents. Site development will proceed in parallel, including construction of access roads and distribution of water and electrical power to the sites. Procurement of long lead-time items will commence. Construction of facilities at one site will proceed during the second and third years, and construction at the second site will proceed during the third and fourth years. This staggered construction plan will permit one engineering and construction team to implement the substantially identical vacuum systems at both sites, maximizing the benefits of experience gained from construction at the first site.

Upon completion of construction activities and acceptance testing at each site, we will proceed with start-up operations and installation of first receivers. We expect that testing, initial facility operation and debugging, and receiver installation, testing and debugging will take one year at each site. The first LIGO antenna should be operational by Summer, 1994, and the completed Observatory should be ready to begin operations in Summer, 1995.

V. RESULTS FROM PRIOR NSF SUPPORT

The preceding work has been supported under separate NSF grants to the science teams at Caltech and MIT (see also Part VII):

Award #: PHY-8504136

Amount of Award: \$3,986,319

Award Period: July 1, 1985-February 29, 1988

Title of Project: "Investigations in Experimental Gravity and Gravitational Radiation"

Principal Investigator: Ronald W. P. Drever, Caltech

Award #: PHY-8504836

Amount of Award: \$3,389,600

Award Period: June 1, 1985-February 29, 1988

Title of Project: "Interferometric Broadband Gravitational Antenna"

Principal Investigator: Rainer Weiss, MIT

Grant funds were applied to research and development activities in gravity-wave receivers, the principal focus of the program, and to preparatory work towards the establishment of the LIGO facilities, (large scale vacuum systems and their enclosures, support structures, and observatory sites). The latter activities were coordinated by a "project manager" who reported to a steering committee, consisting of the principal investigators, Drever and Weiss, and K.S. Thorne, chairman. These efforts laid the groundwork for a joint LIGO facility, reflecting to various degrees a unified program which in September 1987 became formally a reality with the appointment of the present project director R. Vogt and the operational merging of the formerly autonomous programs at Caltech and at MIT. Exchanges of personnel are now taking place, and the 40-meter (Caltech) and 5-meter (MIT) facilities will be operated henceforth as shared facilities.

Work accomplished under the preceding grants may be roughly divided into three areas.

1. Work on prototype receivers including enhancements of their sensitivities.
2. Development of techniques to achieve the aimed for capabilities of the LIGO receivers, but not necessarily related to sensitivity improvements of the present prototypes.
3. Preparatory work and engineering development for observatory facilities other than receivers.

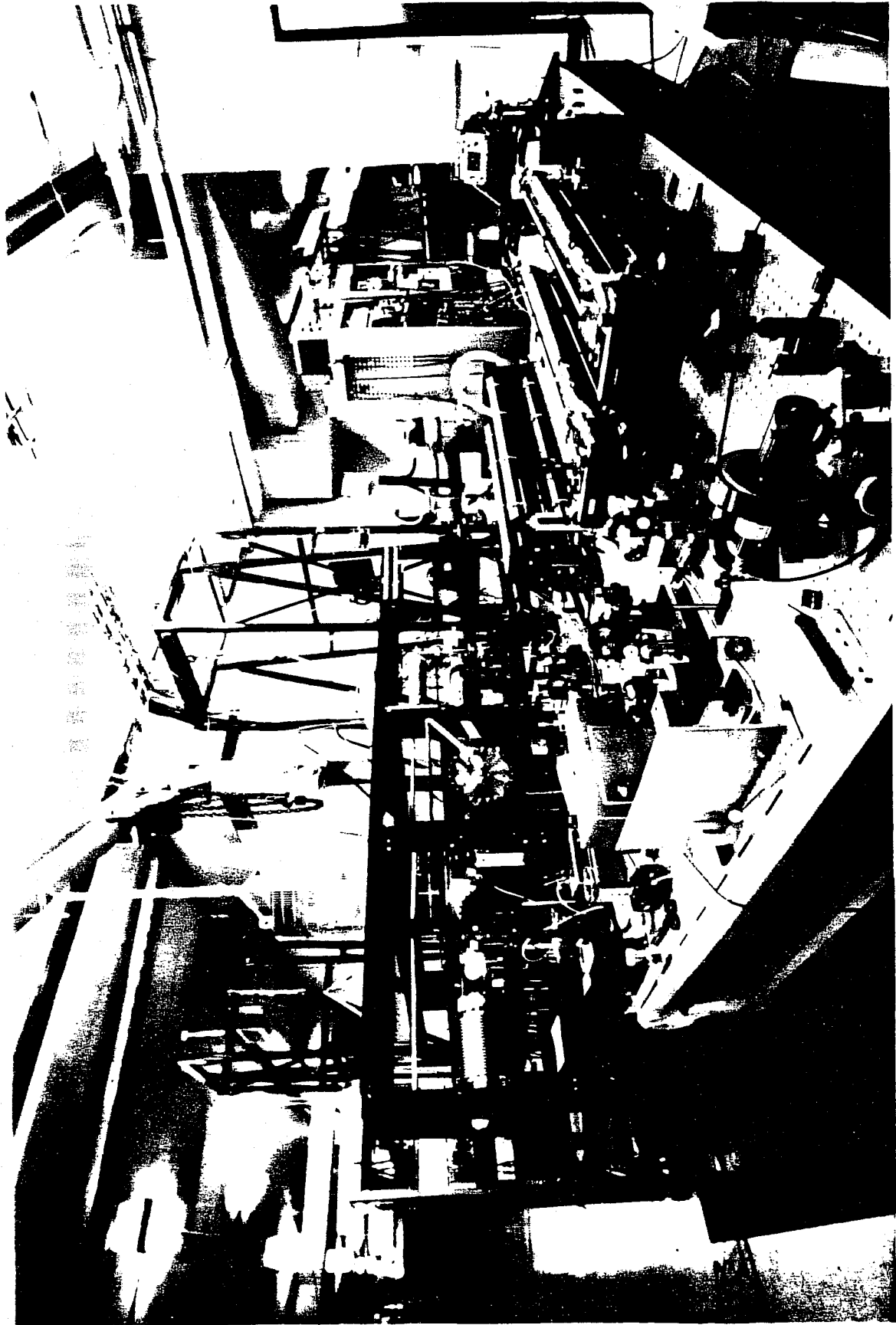

Figure V-1. The 40-meter interferometer at Caltech, as of March, 1987. The central chamber houses the beamsplitter and test masses with mirrors pointing down vacuum pipes stretching to the ends of two orthogonal hallways. A pair of high-power argon ion lasers, visible in the foreground, sends light through a chain of optics into the interferometer.

A. Prototype Receivers

Currently, the Caltech/MIT LIGO team has two operational laser interferometer developmental facilities, a Fabry-Perot type (40-meter armlength) on the Caltech campus, and a Michelson (1.5 meter, delay-line) type on the MIT campus, both operating with argon ion lasers. A third (5-meter) facility, suitable for both Fabry-Perot and Michelson development on a scale appropriate to the LIGO, is under construction at MIT.

1. The 40-meter Facility

a) Fabry-Perot Concept

The research program on the 40-meter facility (Figure V-1) is directed towards developing, testing, and improving gravitational wave receiver designs [References V-1, V-2, V-3] of the Fabry-Perot type appropriate for the LIGO. The current performance of this instrument is about three orders of magnitude better in strain sensitivity than that obtained when put into operation in 1983 (see Figure V-2).

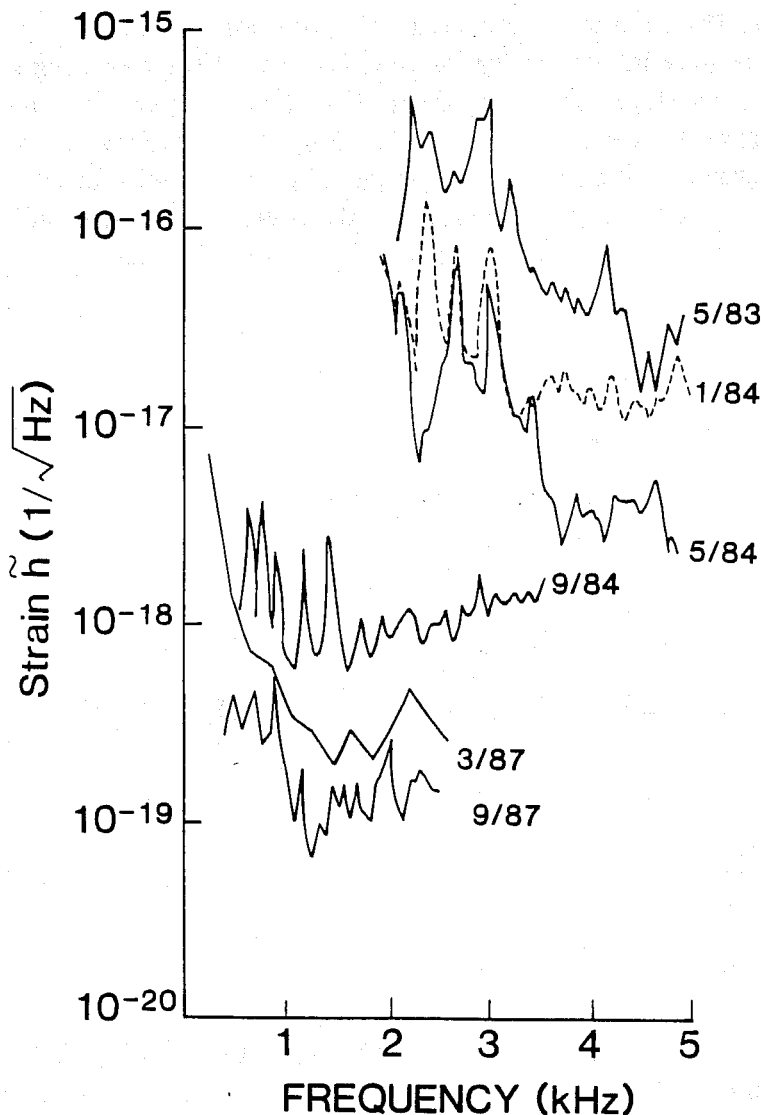

Figure V-2: Progress of the 40-meter prototype. The output of a gravity wave detector is $h(t) \equiv \Delta L/L$, where ΔL is the difference of arm lengths (equation II-1). This output fluctuates stochastically because of the detector's noise. The fluctuations at frequency f are characterized by the square root of the spectral density of h : $\tilde{h}(f) \equiv \sqrt{S_h(f)}$. This "amplitude sensitivity" \tilde{h} , which has dimensions of $\text{Hz}^{-1/2}$, has the property that the root-mean-square amplitude of the fluctuations at frequency f and in a bandwidth $\Delta f = 1/(\text{averaging time})$ is $h_{\text{rms}} = \tilde{h}\sqrt{\Delta f}$. Correspondingly, when searching for gravitational-wave bursts which have $\Delta f \simeq f$, the wave strength detectable at unity signal-to-noise is $h_{\text{rms}} = \tilde{h}\sqrt{f}$; it is this that was plotted in Figure II-2 above. For further discussion see the paragraphs following equation (A.18) in Appendix A.

This series of six spectra shows how the "sensitivity" $\tilde{h}(f)$ has improved over the years. Each improvement is attributable to one or more modifications made to the prototype. The latest four advances were associated with (1) the first use of ultra-low loss mirrors (5/84), (2) the addition of separated compact test masses (9/84), (3) the installation and rebuilding of a high-power laser, and refinement of electronic servos maintaining resonance in the interferometer (3/87), and (4) the installation of fused silica test masses and an in-line mode cleaner (9/87).

The concept of the Fabry-Perot gravity-wave receiver (References V-4, V-5, and V-6) is illustrated in Figure V-3. Light from a laser passes through a beamsplitter to two long Fabry-Perot optical cavities formed by low-loss mirrors attached to four suspended test masses defining the orthogonal arms of the detector. The reflectivity of the prototype end mirrors is made as high as possible (99.995%), and that of the input mirrors is made slightly lower (99.990%). (The transmission of the input mirrors is 0.010%; their losses to absorption and scattering are $\ll 0.010\%$). One or both of the mirrors in each arm is curved to make a stable optical resonator. There is a large resonant build-up of light intensity in each cavity when the cavity length is an integral multiple of a half-wavelength of the light. If losses are negligible, the cavity light (labelled C1 or C2) passing back out through the input mirror for each arm has an equilibrium amplitude equal to twice the amplitude of the light coming to the cavity from the laser. It has exactly opposite phase to that of the light (labelled F1 or F2) externally reflected by the front mirror, so interference between the two components leaving each front mirror gives a resultant reflected beam equal in intensity to that of the beam incident on the cavity. However, the light from within the cavity has travelled back and forth many times between the mirrors attached to the masses (10,000 times in the example mentioned), so any change in the cavity length gives an effective change in optical path and thence in phase for light emerging from the front mirror that is increased by this large number. A gravity wave that causes the length of one cavity to increase and that of the other to decrease will give phase changes of opposite sign in the emerging light from the two cavities, which may be detected with a sensitivity limited in principle only by the statistical fluctuations in the number of photons detected.

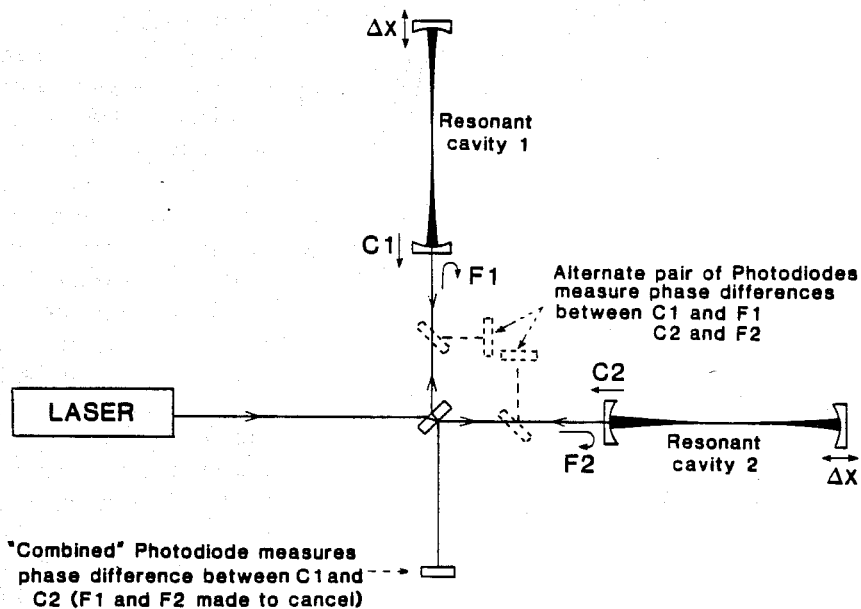

Figure V-3: Principle of Fabry-Perot gravity wave receiver.

The differential phase change may be measured in two ways: either by allowing the two output beams to interfere with one another at the main beamsplitter, and observing

system enclosing the apparatus via a single-mode optical fiber, which reduces seismic and acoustic beam jitter. In addition to the four cavity-mirror masses, two auxiliary isolated structures (one suspended by wires and one on antivibration stacks) carry beamsplitters, isolators, lenses, and other optics that are less sensitive but must still be isolated from external disturbances.

b) Advances in Performance of the 40-meter prototype gravity-wave detector

(i) *Overall Results.* At the beginning of the grant period, the sensitivity of the prototype interferometer was already high (an enormous improvement had been made in 9/84, shortly before the grant period began): the gravity-wave amplitude (July 1985) sensitivity was $\tilde{h} = 5 \times 10^{-19} / \sqrt{\text{Hz}}$ (see caption of Fig. V-2 for discussion of \tilde{h}). This was comparable to or better than that of any other interferometric receiver, and it was achieved using a longer baseline than any other (30% longer than the next largest gravity-wave interferometer, one at Garching, West Germany). During the grant period many improvements were made, resulting in a further advance in sensitivity. The current gravity-wave amplitude sensitivity is indicated as a function of frequency in Figure V-5, in the form of the spectral density of strain noise. Around 1.3 kHz the most recently measured sensitivity \tilde{h} is $8 \times 10^{-20} / \sqrt{\text{Hz}}$. This corresponds to a sensitivity for gravity wave bursts, with $f \sim 1000\text{Hz}$, a factor of 3 worse than the best cryogenic bar gravity wave detectors, but with a bandwidth greater by at least a factor of 1000, along with time resolution better by a factor of at least 100. In terms of flux sensitivity—the unit used for optical telescopes or radio antennas—the sensitivity improvement over the grant period is about a factor of 36.

(ii) *Conclusions from these results.* The strain sensitivity achieved corresponds to a sensitivity of position measurement of the test masses and mirrors of close to 3×10^{-18} meters $/\sqrt{\text{Hz}}$. This sets upper limits to several sources of noise which might have been important, including

- a) thermal noise
- b) seismic noise (confirming other tests that show it to be small)
- c) noise from strain release in the suspension wires or in the masses themselves.

If the displacement sensitivity were maintained at this level in a 4 km system the gravity wave sensitivity would be $8 \times 10^{-22} / \sqrt{\text{Hz}}$, or 4×10^{-20} for a 1 millisecond gravity wave burst.

(iii) *The experimental advances that have led to this sensitivity improvement:*

Installation of a higher power argon laser. At the beginning of the period the interferometer was powered by a Lexel argon laser of nominal all-line output 4 watts. Installation of a Coherent Innova large frame argon laser of nominal all-line power 20 watts, and actual power at 514 nm in a single mode about 3 watts, made possible a significant increase in power into the interferometer (though the performance in Fig. V-5 was achieved with an input power of only 25 mW). The laser as supplied by the manufacturer had considerably larger frequency noise than the smaller laser. This was overcome eventually by a number of steps, including a)

the effect in the resultant "combined" light with a photodiode; or by measuring the phase change in each cavity separately by diverting the output light to photodiodes (shown by dotted lines) that observe interference between the light emerging from each cavity and that reflected from its own input mirror. The 40-meter system has used the latter method up to now.

A technique for precisely stabilizing and controlling the laser wavelength to match a cavity resonance is an essential part of the concept, and is carried out by phase modulating the laser beam at a radio frequency, obtaining a measure of deviation from resonance by coherently demodulating the photodiode output, and using the error signal to fine-tune the laser or the length of the cavity. The arrangement is shown, in simplified form, in Figure V-4.

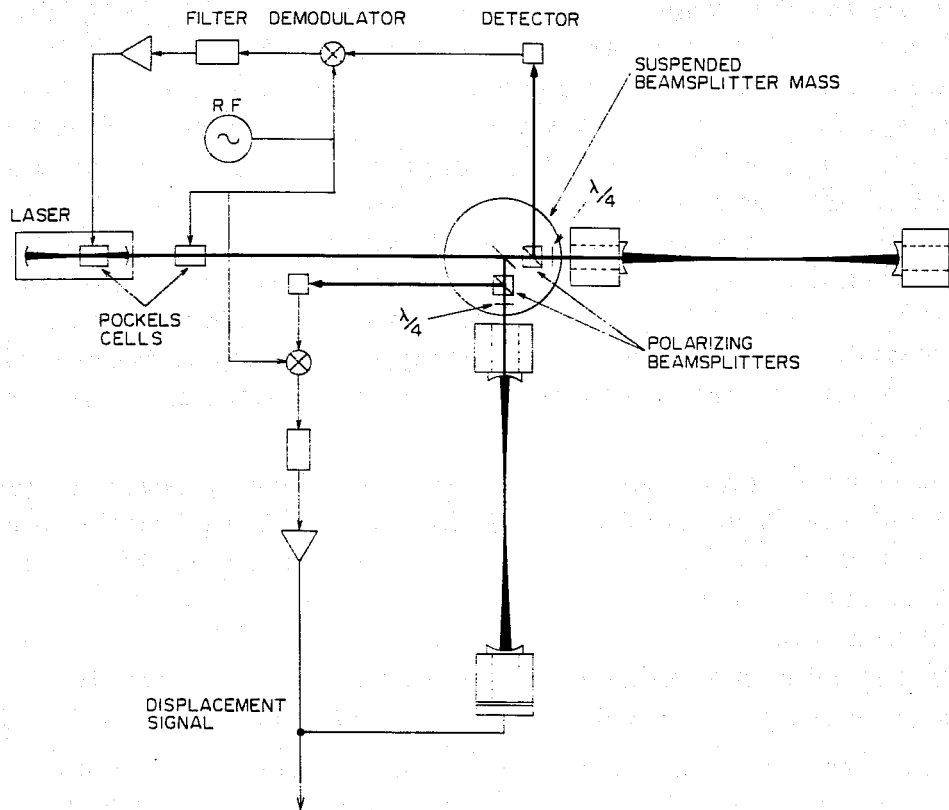

Figure V-4: Simplified schematic of prototype Fabry-Perot receiver operating in a mode where the laser's frequency is locked to the upper arm's cavity, and the gravity-wave signal $h = \Delta L/L$ is read off the lower arm's cavity.

The mirrors at present (Autumn 1987) are optically contacted to fused silica test masses, hung by thin steel wires from a suspension system that isolates the test bodies from external forces while allowing precise control of mirror angle and position. The alignment of the mirrors is sensed using optical levers employing auxiliary helium-neon lasers; low-frequency data on the position of the masses relative to local ground comes from auxiliary optical sensors, while data concerning the difference in cavity lengths are derived from the main interferometer. The input laser beam enters the vacuum

removing the laser cavity mirrors from the laser frame and mounting them directly on a heavy optical bench less affected by vibrations from flow of cooling water, and *b*) improving the frequency stabilization servo system—which uses a Pockels cell within the laser, supplemented by a piezo-driven laser cavity mirror for slower larger-range control.

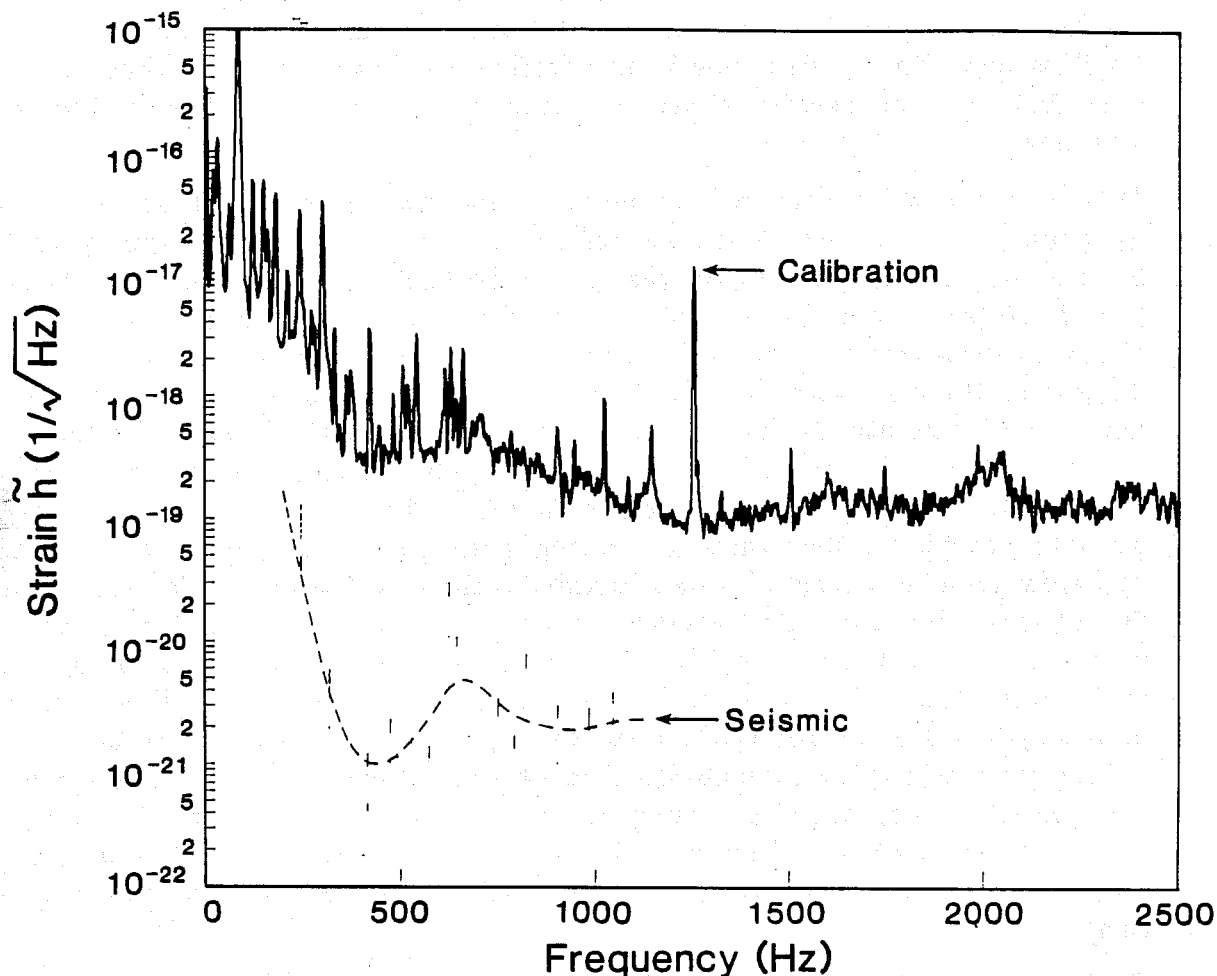

Figure V-5: Sensitivity of the 40-meter prototype, \tilde{h} , as of October 1987. The peak marked “calibration” is the effect of imposing a 10^{-15} meter rms sine wave motion on one of the test masses (given the 4.7 Hz bandwidth of this measurement, the calibration corresponds to $5 \cdot 10^{-16}$ meters $/\sqrt{\text{Hz}}$; (to convert from strain to displacement, multiply the scale by 40 m) or $\tilde{h} = 1.2 \cdot 10^{-17}/\sqrt{\text{Hz}}$. At 1.3 kHz and above the sensitivity agrees (within the estimated uncertainty factor of 1.5) with the calculated shot noise limit [V-7], for the measured available photodiode power of 25 mW. The broad peak near 2 kHz is probably an artifact of imperfect calibration, and the collection of peaks below 500 Hz is probably from mechanical resonances in the beamsplitter mass, steering mirrors, and the laser. The lower curve is a fit to the response of the detector to external vibrations, sampled at several discrete frequencies. The data, obtained by attaching a commercial vibration tester to the table supporting one of the vacuum chambers and scaling the resulting “gravity wave” signal to the ambient noise, shows that seismic motion contributes a negligibly small fraction to the total noise in the signal.

Development of the electronic feedback system has allowed the loop bandwidth to be increased to give a unity-gain frequency of about 1 MHz, and allowing significant increase in loop gain at low frequencies. A very high degree of frequency stabilization is now achieved, such that the servo loop error signal can be brought close to the photon shot noise. The independent check on residual frequency noise made by the operation of the two arms of the gravity wave interferometer has shown that residual frequency noise is less than 1 in $3 \times 10^{18} / \sqrt{\text{Hz}}$ over timescales of order 1 millisecond. This corresponds to an effective linewidth over these time scales of order 10^{-4} Hz: an exceptional degree of frequency stability in a laser of this type and power.

Development and installation of low noise test masses. The design of the test masses has gone through successive stages of refinement as various sources of spurious noise have been found to originate in them. At the beginning of the present funding period the test masses were aluminum cylinders, with the fused-quartz substrates of the low-loss mirrors acoustically connected to them by vacuum grease, to allow differential thermal expansion. Experiments at Glasgow indicated that such grease joints could generate low-level noise; and measurements at Caltech of mechanical Quality factors ("Q") of complete test mass assemblies confirmed that the damping and elastic properties of the grease could cause the mirrors to act as a low-Q oscillators coupled to the masses, generating thermal noise. The grease was replaced by harder joints made by a low-loss bonding technique. This gave high mechanical Q and lower noise, but also resulted in serious distortion of the mirrors due to mismatch of expansion coefficients between mirrors and test masses. Finally, as at Glasgow, the problem was solved by making the masses themselves of fused-quartz cylinders and forming the bond to the mirrors by optically contacting the mating surfaces, relying on molecular forces to make the joint. This technique gives good noise performance and is currently used for all test masses in the 40-meter system. (The possibility of applying the low-loss mirror coatings to the test masses themselves is being considered, although there are some practical problems in doing this).

Replacement of piezo-electric transducers between mirrors and test masses by magnetic and electrostatic drive to the masses themselves. There has long been suspicion that piezo transducers between the mirrors and test masses—which were used to give fast adjustment of the cavity mirrors for locking the cavities into resonance with a laser beam—could be a source of noise, by such phenomena as the electrostatic analogue of the Barkhausen effect. The piezo transducers were, therefore, removed, and the system was redesigned in such a way that fast control accelerations could be applied to two of the test masses by interaction of applied magnetic fields with small magnets attached to the masses. This has proven very successful, with an operating frequency limited mainly by the fundamental resonance of the masses (which is about 30 kHz with the present design), and has contributed to the improved noise performance.

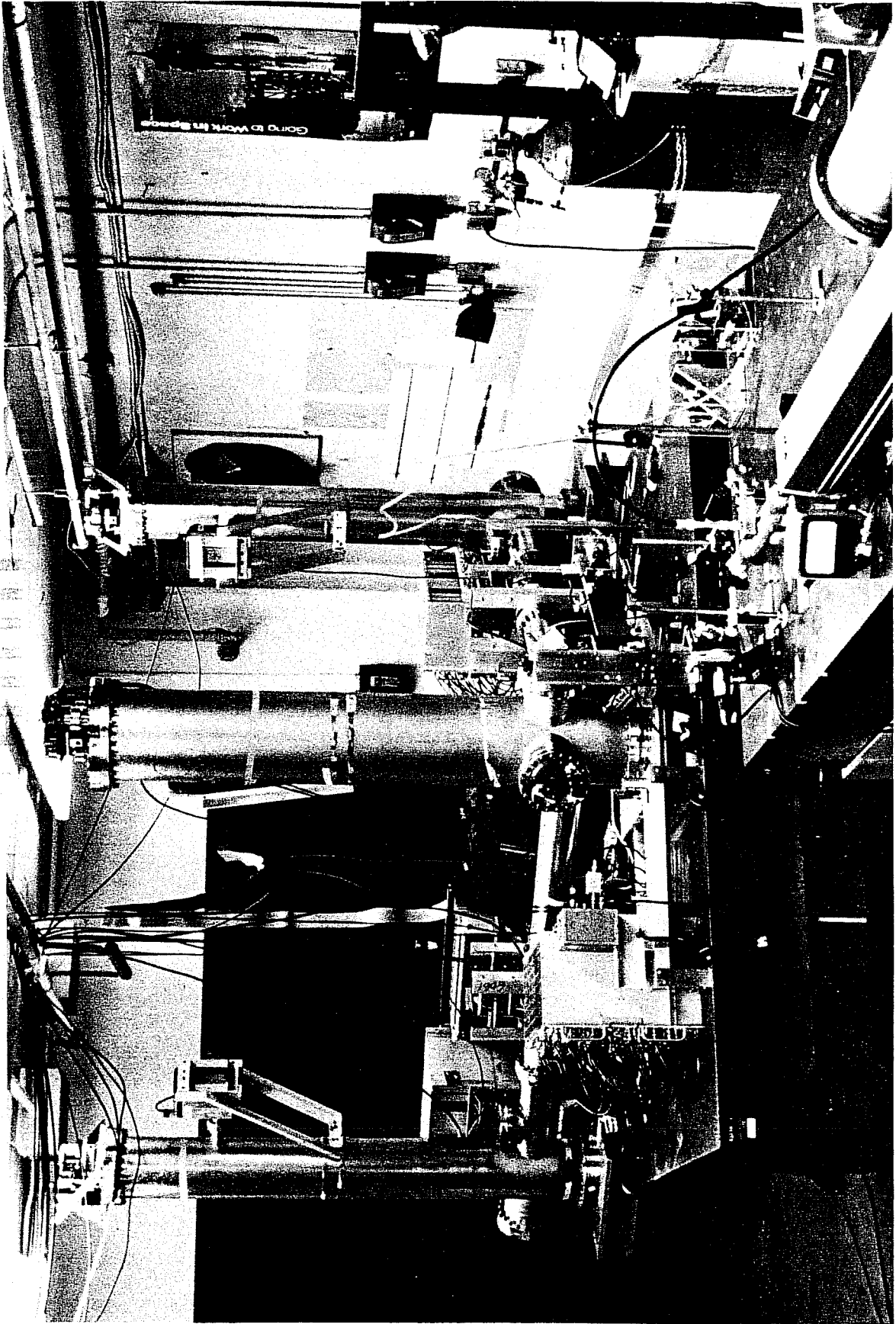

Figure V-6: A photograph of the 1.5-meter delay line facility.

Use of a narrow-band transmission Fabry-Perot cavity to filter the laser beam. The continuing search for sources of noise gave evidence for production of noise by non-linear mixing processes in some of the feedback systems used to lock the main optical cavities into resonance with the laser light. Fluctuations in the laser amplitude, frequency, and beam geometry at frequencies well above the gravity-wave frequency, are a possible source of such processes. To remove this noise, the laser beam is now passed through an optical filter (Fabry-Perot cavity) of 200 kHz bandwidth which is kept in resonance by a suitable servo arrangement. Use of this technique, which had been incorporated earlier in the 40-meter system as a means of reducing fluctuations in beam position and then deferred, has been accompanied by an improvement in sensitivity. Work is currently in progress to study further the reason for the improvement in sensitivity obtained with this "mode cleaning" cavity and to develop the technique further.

2. The 1.5-meter Facility

a) *Delay-line (Michelson) concept*

The concept for a delay line Michelson interferometer gravitational wave detector was developed in 1971 [V-8]. The instrument (Figure V-6) became operational in 1983 and has been used to demonstrate basic receiver concepts.

The delay line Michelson prototype receiver is a practical implementation of the simple interferometer described in Part II.A (see Figure V-7 for block diagram). The major difference is that after being divided at the beam splitter, the light enters two orthogonal open cavities formed by mirrors on the corner and end masses. The light makes multiple transits in these cavities to increase the optical phase shift associated with a change in cavity length. The light enters and exits the cavities through holes in the mirror. The light emerging from the cavities passes through electro-optic crystals that impress an RF phase modulation, the equivalent of a small periodic variation in length, on the light before recombination at the beam splitter. When the instrument is locked to a fringe, two light beams leave the beam splitter; one is the sum of the recombined electric fields (the bright fringe) and the other is the difference (the dark fringe). A photodetector and associated electronics are used to interrogate the modulation of the dark fringe and thereby split the fringe. The precision by which the fringe can be split is determined by the light power in the bright fringe, at present the dark fringe is split into 10^6 parts in 1 millisecond. The signals developed by these means are then used to control the optical length of the cavities to hold the instrument on a single point of a fixed fringe. In practice, this is the "white light" fringe—the fringe associated with light that has spent equal times traversing the two cavities, the position of which is independent of the laser frequency. The optical path length control is asserted by feedback to the electro-optic crystals and to electrostatic controllers that move the mirrors. All effects that tend to lengthen one cavity and shorten the other, such as gravitational wave forces and noise forces, are measured in the feedback signals.

The mirrors, which form the end points of the cavity, are suspended by fibers so that for frequencies above the resonance frequency of the suspension, they respond freely to gravity waves. The suspensions have very low intrinsic damping to reduce the coupling

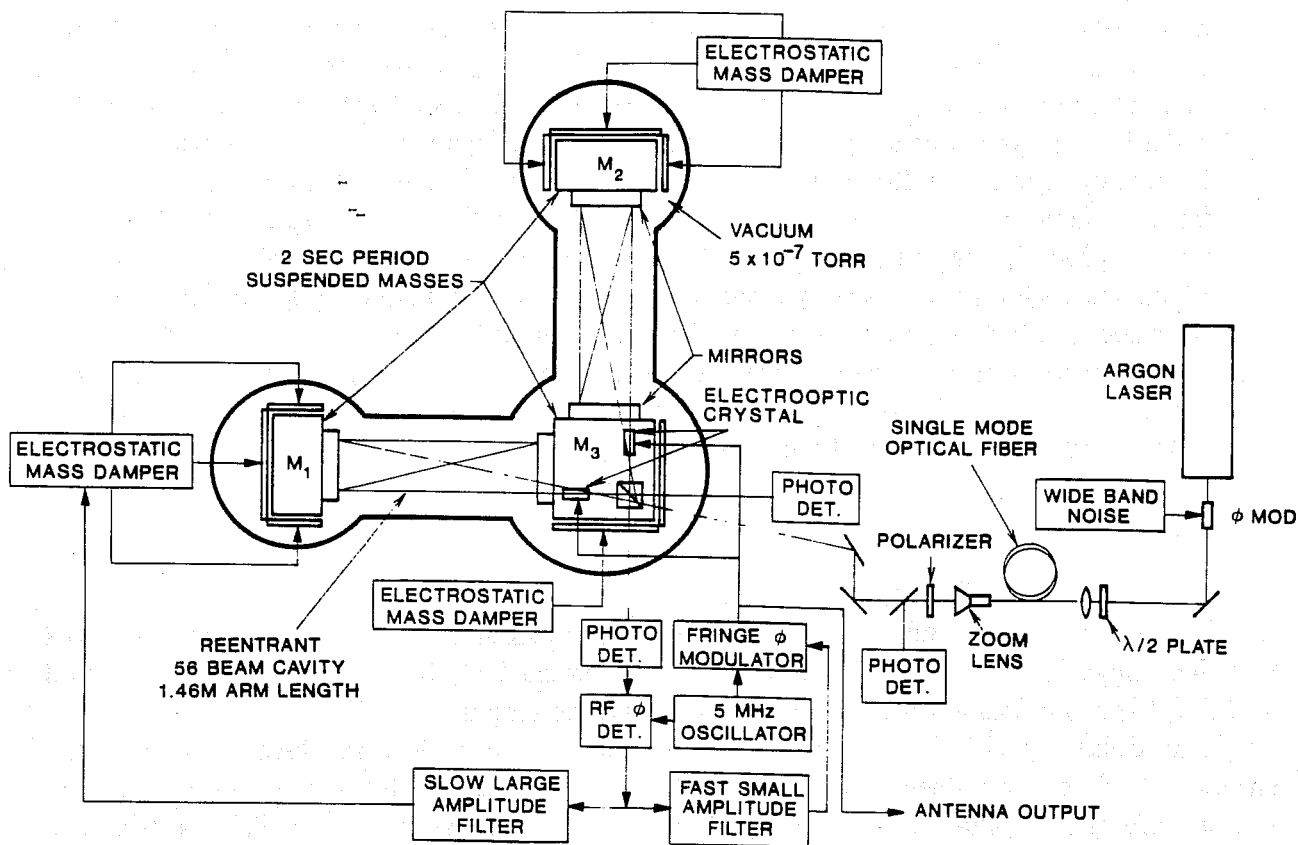

Figure V-7: Schematic of 1.5 meter delay line prototype.

to externally driven seismic and acoustic disturbances as well as to minimize their thermal noise off resonance. The mirror motions at the suspension resonance frequencies are damped electronically in all six degrees of freedom by a system of capacitive position sensors and electrostatic controllers. A more extensive description of this prototype receiver is given in Appendix H and Reference V-9.

b) Results

At the beginning of the present grant period, the 1.5 m prototype had not long been in operation and its sensitivity was rather poor. Improvements in the amplitude sensitivity during the grant period were substantial: a factor of about 200 in amplitude sensitivity at a frequency of 1kHz (the present noise spectrum is shown in Figure V-8). This was the result of diagnosis and correction of various noise sources in different parts of the spectrum.

c) Improvements

The sensitivity of the 1.5-meter receiver at low frequencies (0-2 kHz) was improved by the installation of a series of new suspension systems, beginning with a vacuum compatible horizontal isolation system (a stack of stainless steel plates and Teflon rods), and ending with the complete replacement of the original suspension with a single wire

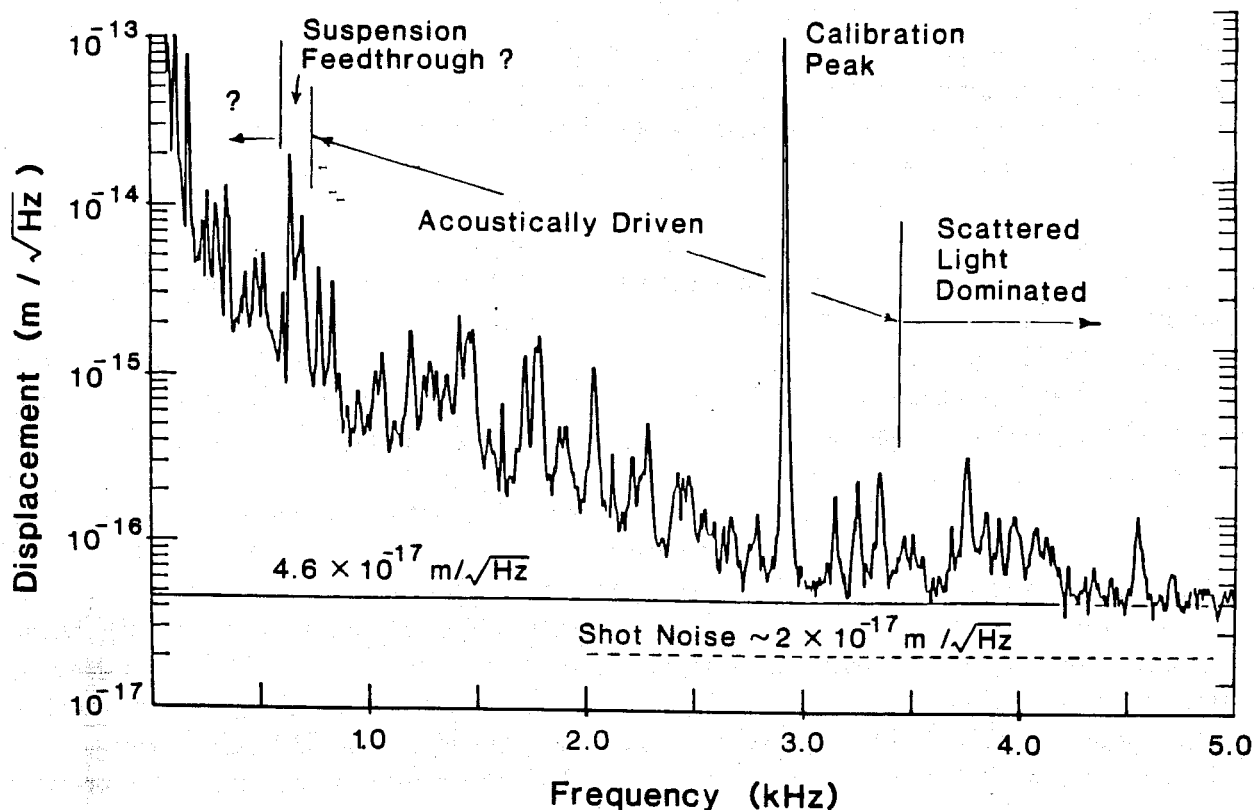

Figure V-8: Typical displacement noise spectrum from the 1.5 meter prototype. The displacement noise is given in units of meters in a one second integration time as a function of observing frequency. The strain noise is the position noise divided by the length of the cavity, 1.5 meters. The spectrum was taken with 60 milliwatts of power emerging from the symmetric output of the interferometer. The system has been run at over 100 milliwatts but the noise spectrum is not improved, indicating that the noise is not dominated by shot noise.

system. Coarse mechanical positioning of the suspensions was mechanized with the installation of motorized micrometers.

At mid-range frequencies (1-5 kHz) the noise floor of the prototype was improved by acoustically shielding the apparatus from the room with a foam and rubber curtain.

High frequency noise (≥ 5 kHz) was reduced with the installation of a broadband phase modulator to suppress the effects of scattering. The shot noise limit was reduced slightly with the installation of a higher power laser, after extensive modifications to the power supply to reduce the intrinsic noise.

The front end electronics for the main photodetectors were improved. The output optics were modified to reduce reflection losses at the photodetectors, and work is in progress to install an optical fiber as an output coupler.

A data acquisition system capable of recording large amounts of continuous data with precision atomic timing was added and used to collect data.

d) Noise analysis techniques

Direct measurements of the effect of mechanical vibration and acoustic noise on the interferometer output were made. Forces applied to the top of the wire suspensions using a magnetic driver and a piezoelectric transducer (PZT) determined the vibration transfer function; except at resonant peaks, direct feedthrough did not dominate the interferometer noise spectrum. Driving the external mode-matching optics with the PZT showed those components to be the coupling path for acoustic noise.

A separate facility was set up to test suspension designs. These tests led to the purchase of a Ling electromechanical driver and to the design of an auxiliary suspension vacuum chamber as part of the new 5 meter facility.

The development of methods for detecting and reducing the effects of scattered light led to the implementation of two methods for suppressing the effects of scattering: one method based on phase modulation with broadband gaussian white noise, the other on pseudo-random digital noise.

A vibrating wire amplitude modulator was constructed to measure the transfer function from audio frequency laser amplitude noise to interferometer noise. These measurements showed that amplitude noise was not a dominant noise term.

A circuit was constructed that allowed readjustment of the arm-length difference of the interferometer, one fringe at a time without losing fringe lock. This was used to investigate the sensitivity of the interferometer to laser frequency noise and to find the region near the white light fringe. The noise was reduced by 10 dB in the process.

A technique for examining the fringe signal on the photodetectors and separating the contributions of phase noise and amplitude noise was developed and used to guide the choice of operating conditions for the scattering suppression techniques. It also led to the development of new Brewster angle Lithium Tantalate electrooptic modulator geometries.

Methods to characterize the noise and modal properties of optical fibers were also developed.

e) Conclusion

A number of important contributions to the noise spectrum of the 1.5-meter interferometer were successfully identified. Several of the required improvements, such as moving the input coupling optics inside the vacuum chamber and the installation of separately suspended optical components, simply could not fit in the restricted vacuum system of this prototype. This was crucial in the decision to build the 5-meter system.

3. The 5-meter Facility

In the spring of 1986 design work began on a new 5-meter prototype interferometer. The vacuum system was designed to house either delay line Michelson receivers or Fabry-Perot receivers with optics large enough for a 4 km system; and the vacuum system uses techniques applicable to a 4 km system. The vacuum system was installed and qualified in Summer 1987 (see Part VI.B).

B. Development of Capabilities for LIGO Receivers

1. Work performed at the 40-meter facility

During the present grant period, many experimental techniques have been developed with the aim of controlling many sources of noise that have to be kept under control but may not yet be serious in the 40-meter prototype receiver:

a) *Seismic Isolation for the 40-meter receiver.*

(i) *Measurement of Achieved Isolation.* The seismic isolation system used from the beginning in the 40-meter receiver is a simple passive system, with a 4-stage lead-rubber stack within the vacuum system as a major element, together with the natural pendulum isolation of the test mass suspension, and provision for external air suspensions—which are normally not used. The isolation system is based on well-established methods used in bar gravity-wave detectors, and has shown no sign of high-frequency feedthrough. Experimental measurements of attenuation have been made with the interferometer, exploiting the fact that each end station is on a separate foundation giving isolation from the ground and from one another. The optical bench forming the base of one end station was vibrated by a powerful vibration generator at a range of frequencies, at amplitudes which were increased until feedthrough was apparent on the interferometer. The imposed motion was monitored with an accelerometer and seismometer, and compared with the natural ground motion. Assuming the feedthrough is linear, the data were scaled to indicate an upper limit to the feedthrough of ground noise, and the results are shown by the lower curve in Figure V-5. This indicates that the attenuation of the isolation system is indeed satisfactory at frequencies above a few hundred Hz even for the ground noise at Pasadena, a built-up area with busy roads. Scaling to the measured seismic noise at potential LIGO sites indicates that the isolation system used in the 40-meter instrument should be adequate alone for initial receivers in the LIGO above a frequency of about 400 Hz. For LIGO receivers aimed at lower frequencies, however, further isolation will be needed and for this we plan to develop active systems in addition to passive systems.

(ii) *Introduction of a system for enhancing low-frequency seismic isolation.* The passive isolation system in the 40-meter interferometer has proven convenient and satisfactory at frequencies above a few hundred Hz, but it does transmit very low frequency motions (of order 10 Hz and lower) imposing large dynamic range requirements on the servo systems that hold the cavities in resonance; this can make acquisition of lock difficult at times, such as when there is nearby traffic. A simple helium-neon interferometer has been added to monitor the distance between the suspension points in one arm of the system, with the intention of feeding back the changes so that the two suspension points track one another and give a first-order cancellation of low frequency disturbances. The technique looks promising.

b) *Development of a High Performance Laser Intensity Stabilization System.*

The use of radiofrequency modulation techniques makes the basic interferometer insensitive in first order to laser intensity noise in the gravity-wave frequency region, but

at the high sensitivity involved second-order couplings can be important. The performance of available commercial laser stabilizers is limited, partly due to nonhomogeneity in the laser beam and changes in the beam pattern caused by the action of the electrooptic intensity modulator usually employed to control the beam. A stabilizer with higher performance has been developed for use with the 40-meter system, in which a length of optical fiber follows the modulator to remove fluctuations in beam geometry before the intensity is sampled by the monitoring photodiode. This system gives a high degree of stabilization. In typical operation the interferometer can be made sufficiently insensitive to intensity noise for stabilization to be unnecessary, but it is used as a test for intensity noise feedthrough at every new advance in detector sensitivity.

c) Further Development of an Automatic Cavity Alignment System.

Precise control of beam and mirror alignment is important in interferometric gravity wave detectors. In the 40-meter detector the mirror and test mass orientation is monitored by optical levers and maintained steady by servo systems which suitably adjust the relevant suspensions. Setting up this system for optimum alignment is time-consuming, and drifts occur over several hours. A new technique for making the system optimize its own adjustment was devised just prior to the current grant period, as an extension of the basic radiofrequency laser frequency stabilizing system. The alignment system measures the gradient of phase difference between the wavefronts of the light emerging from a Fabry-Perot cavity and the incident beam reflected from the input mirror, and can adjust the alignment to make the wavefronts coincide. An experimental model of this system has demonstrated satisfactory operation on one of the 40-meter arms of the interferometer while the cavity is in resonance, but in its simplest form the system requires manual attention if the resonance is lost for any reason. A recent further development has been the addition of a computer control system that monitors operation of the alignment servos, keeps the manual optical lever servo system in correct adjustment while the automatic system is operating, and switches over to the optical lever system if the automatic system fails or the cavity falls out of resonance. This is the first stage in the planned automation of the interferometer, which will greatly improve the operating efficiency of the 40-meter instrument and will be essential for the longer arms of the LIGO system.

d) Other Research Developments.

Several other areas of development and research have been advanced significantly. We summarize some of them here.

- (i) Studies of thermal effects in low-loss cavity mirrors: The work is still in progress, but already it indicates that the practical sizes of the LIGO mirrors are such that heating problems will not be serious.
- (ii) Development of an electrostatic control system for test masses: A constant-charge technique for giving electrostatic forces independent of position of the mass has been used in a feedback control system, and looks promising.
- (iii) Experimental studies of the noise from piezoelectric transducers. These studies have set an upper limit to the Barkhausen effect that is small enough to be insignificant in our present mode of use of the devices.

- (iv) Redesign of the vacuum system: A design has been developed for a larger vacuum tank, pipes, and seismic isolation system to enable the 40-meter system to be more effectively used for optical systems with many more components suspended in vacuum (such as recycling interferometers), and to accommodate larger test masses. A tank is being prepared for this upgrade to the facilities, and the laboratory building is being modified. More details are given in Section VI.

2. Work performed on the 5-meter facility

Development of techniques in seismic isolation

A prototype model of a multiple double pendulum suspension (Figure V-9) has been designed and constructed. The model is the size appropriate for Fabry-Perot mirrors for a 4 km baseline. Careful noise budgeting of all control elements should make all stochastic noise terms associated with suspensions negligible above 100 Hz. The model includes control of all twelve degrees of freedom using optical position sensors, magnetic actuators on the outer mass, and astatized (zero force gradient) electrostatic actuators on the mirror. If scaled up for 4 km delay line mirrors, the electrostatic actuators could be used to servo the mirror figure.

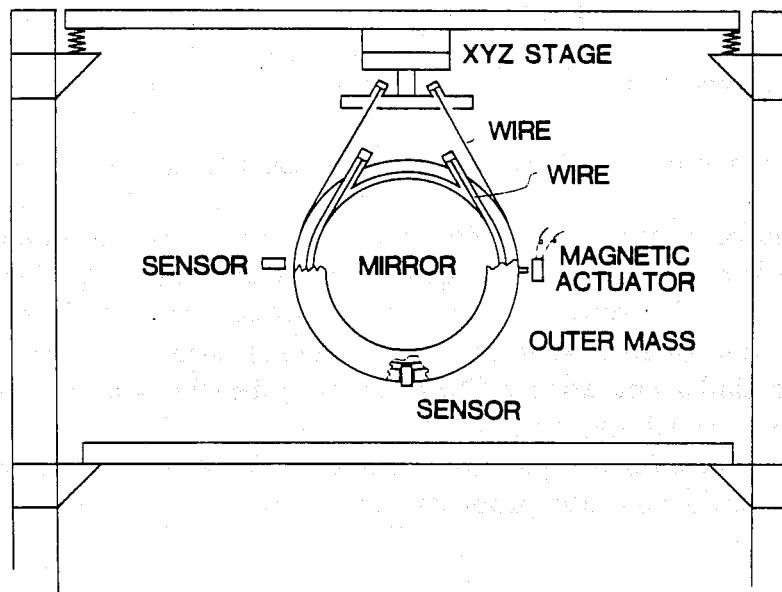

Figure V-9: A schematic diagram of the multiple suspension system under development for the 5-meter prototype.

A magnetic suspension (Figure V-10) to serve as an outer stage in the vibration isolation chain has been designed and constructed. Its major advantage will be as a mass-spring system without the pernicious internal mechanical resonances of conventional springs. It also is a compact way to build a suspension with a low resonant frequency, and damping should be adequate without the use of vacuum incompatible materials.

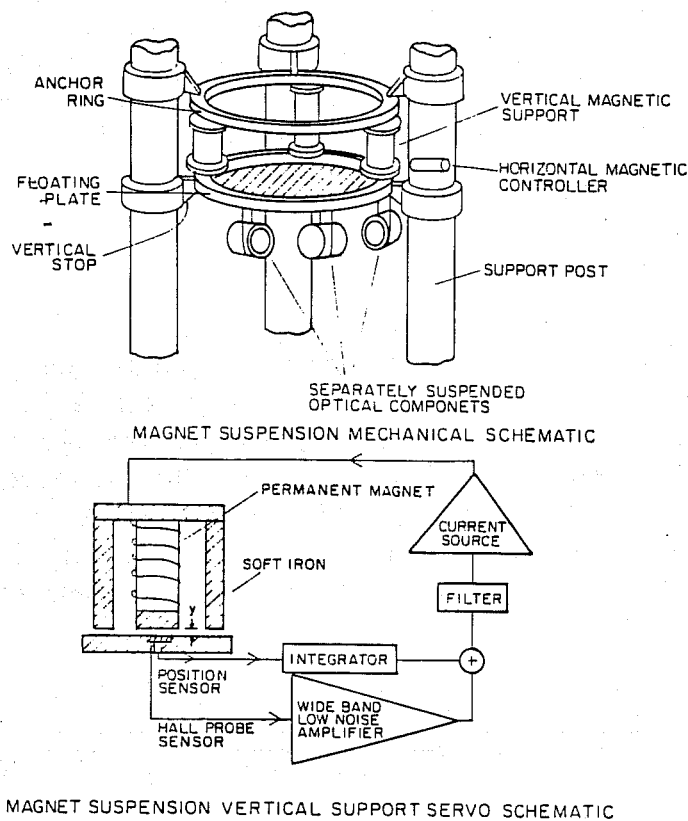

Figure V-10: Schematic diagram of the magnetic suspension being developed.

Two new designs of optical position sensors have been prototyped and tested. One is an optical shadow sensor based on quadrant photodiodes. A compact unit holds an infrared LED and the quad cell, sensing the shadow of a dark mask on a nearby flat polished surface. A more sensitive interferometric sensor (Figure V-11) based on single-mode laser diodes and optical fibers has also been built and tested. It holds the promise of position sensitivity near 10^{-14} meters/ $\sqrt{\text{Hz}}$. Both types of sensors have been designed with vacuum compatibility and large dynamic range in mind. They are suitable for small-scale quantity production to meet the demand for roughly 50 per interferometer.

3. General Developments in Support of Receiver Technology

a) Development in optics

Research was carried out on electro-optic modulators and fibers for high power applications both at 0.514 and 1.06 microns. The electrooptic coefficients, dielectric loss tangent at RF frequencies, and the transmission at 0.5 microns of Potassium Titanyl Phosphate (KTP) was measured. The material has a laser damage threshold similar to quartz. Techniques have been developed to make Brewster angle Lithium Tantalate phase modulators with small piezoelectric coupling. The material exhibits low optical loss and a high damage threshold at 1.06 microns and, furthermore, a small loss tangent

4. Development of Data Analysis Techniques and Searches for Gravitational Radiation

Both the 1.5-meter and the 40-meter prototype receivers have been operated in gravitational wave searches. Even though the receivers are development devices and of insufficient sensitivity to have much chance of seeing waves, we believe it is important to evolve techniques to search for gravitational waves in their prototype data streams. There are several reasons for doing this: the techniques will find application in the LIGO project and the process of developing and using them highlights the problems that will be encountered in an actual observation run on the LIGO, thereby aiding the LIGO design. Furthermore, in a university setting it is important that Ph.D thesis work be involved with actual physical measurements.

The 1.5-meter prototype accumulated 30 hours of data distributed over two weeks in June, 1985. The data were analyzed (see Appendix I) for gravitational wave bursts by cross correlation theoretical wave-form templates in the 800 Hz to 5.5 kHz band [V-14]. The same data were also searched for periodic sources between 2 and 5 kHz, of unknown period and unknown position in the sky. The analysis, using a computational technique to remove the Doppler shift due to the earth's motion, gave a null result [V-15]. This search, which required use of a supercomputer, highlighted the severity of the computational problems that must be faced in LIGO searches for periodic sources.

An algorithm was developed to search for the characteristic "chirp" of coalescing binary star systems [V-16].

An analysis was performed of the relative projected sensitivities of the best current acoustic antennas and current interferometric antennas for bursts originating from galactic impulse events such as SN 1987A [V-17].

Coincidence runs following SN 1987A

The optical observation of Supernova 1987A on 23 February 1987 and the discovery of coincident signals in the archives of two neutrino detectors, consistent in timing and flux with the optical observations and with models of core collapse, was impetus for a series of coincidence runs between Caltech and MIT. Approximately five hours of high-bandwidth data, including atomic standard timekeeping, were collected on March 8 and March 10. The University of Glasgow participated, making these the first three-way coincidence experiments with interferometric gravitational wave detectors. The receivers, which were all down at the time of the supernova, were brought on line, the coincidence runs were organized, and the runs were successfully completed all within two weeks of the discovery of the supernova. Analysis of the data for burst signals and periodic signals is now underway.

C. LIGO: Large Baseline System Development

1. Conceptual Design and Cost Studies

The essential requirements (Part IV) for the LIGO facilities were formulated during the present grant period. A functional requirements document and the conceptual design of the LIGO for use as input to an engineering design were partially completed. Engineering and cost tradeoff studies were carried out on many of the cost driving

at RF frequencies. A research program was undertaken with industry to develop large diameter single mode fibers to increase the power that could be transmitted by fibers. A single mode fiber with 12 micron core diameter was developed for use at 0.5 microns.

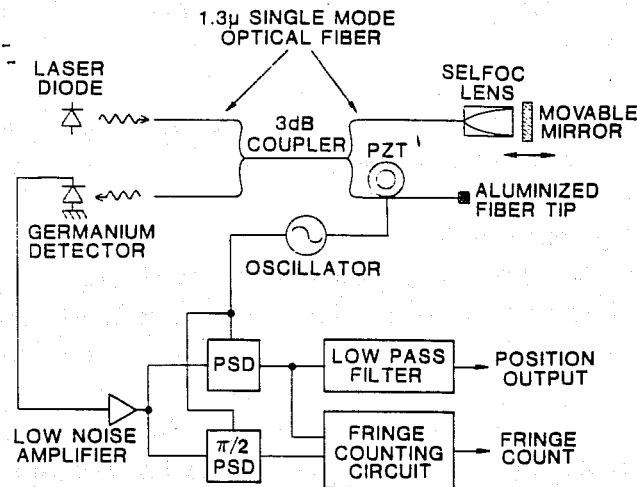

Figure V-11: Schematic diagram of a fiberoptic position sensor. If further tests using a suspension feedback diode laser are successful, the sensor will be adopted for standard use in suspension damping systems. The output of a single laser can be divided by fiber stars to illuminate up to six of these sensors.

b) Nd:YAG laser research

Early in the present grant period a study was made of laser light sources that could develop up to 100 watts CW efficiently and have the frequency, amplitude, and mode purity required in precision interferometry. A promising system identified was the Nd:YAG laser which during the last three years has undergone remarkable development. The invention of the laser diode pumped single crystal ring oscillator by Prof. Byer at Stanford [V-10] (now commercially available) has offered the field a new laser with unprecedented low intrinsic frequency and amplitude noise. Our measurements of a 5 mW unit indicate a frequency noise less than $20 \text{ Hz}/\sqrt{\text{Hz}}$ at frequencies as low as 100 Hz. The amplitude noise is approximately 15 times shot noise at 1 kHz and approaches shot noise at high frequencies. The laser is well suited to be the master oscillator in an amplifier chain or as a seed for the injection locking of a power oscillator.

A cooperative program with the GE Research Laboratory (Dr J. Chernoch) was initiated to test Nd:YAG zig-zag slab lasers as power oscillators or as a final amplifier stage for a high power system [V-11, V-12]. Measurements were made of the gain per pass of a small slab laser head (loaned by GE to the LIGO project) to evaluate it as an amplifier. GE is concurrently measuring the power that survives in a single radial mode of a new slab head operating at 700 watts CW multi-radial mode.

This Nd:YAG research has been directed to developing a source at 1.06 microns; new developments [V-13] show promise for frequency doubling.

elements of a LIGO facility. These include: (i) the vacuum pumping strategy (cryopumps, sputter pumps, and trapped diffusion pumps were evaluated; the preliminary choice is turbomolecular pumps for initial evacuation and ion pumps to hold the vacuum); (ii) tubing design (corrugated thin wall stainless steel tubes, aluminum tubes, and nested tubes differentially pumped were evaluated; the preliminary choice is spiral welded stainless steel with periodic stiffening rings, an established and low risk technology); (iii) protective cover for the tubes (no cover, corrugated culvert, corrugated pipe arch, concrete used on surface, partially buried and completely buried configurations were evaluated; the preliminary choice is bermed concrete). As a guide to the trade-off studies a detailed work breakdown structure (WBS) and associated trial schedules were developed to highlight relationships between cost items and to identify long lead items and hidden costs. The tradeoff studies are not complete and will be continued during the next year to evolve the best compromise between economy and risk.

2. Observatory Site Activities

A second iteration after an initial 1983 study of sites was made in New England, California, Nevada, Illinois and Utah. Edwards AFB in California and Columbia, Maine were selected as possible sites for further study for reasons of topography, remoteness from manmade noise sources while retaining access to transportation, power, labor, and material for construction, and having reasonable proximity to Caltech and MIT, respectively. Preliminary work to evaluate the sites was carried out. Seismic noise measurements were taken at both sites. At Columbia an aerial and ground survey was made and preliminary geotechnical work was done at locations suspected of having subsurface rock formations. An archaeological survey was performed and negotiations to evolve an environmental impact statement were begun. The ability to acquire the sites was evaluated. At Edwards a Memorandum of Understanding, dealing with security issues, but not committing us or the Air Force to the site, was signed with the Air Force. At Columbia the land is privately owned and exploratory contacts were made with landowners using a local lawyer and assessor.

A LIGO sites working group was established to determine the scientific requirements for sites so as to optimize both the near term goal of discovery of gravitational waves and the longer term needs for gravitational wave astronomy. Results of this study are reflected in Appendix B.

3. Receiver Designs for the LIGO

a) Conceptual design of a Fabry-Perot receiver system for initial operation in the LIGO

Work with the 40-meter system and with earlier Fabry-Perot interferometers has given us sufficient experience and confidence in the techniques to make possible a fairly complete design of an initial Fabry-Perot receiver for the LIGO; and such a design has been developed recently. An outline of key aspects of this design is given in Appendix F to this Proposal. It is worth noting that development of this design has stimulated several new technical concepts, such as methods (i) for reducing demands on mirror precision, (ii) for keeping modulators out of high-intensity beams, (iii) for controlling alignment and other parameters, and (iv) generally for constructing a series of economical and effective interferometric detectors.

b) Conceptual design of a Delay Line Michelson receiver for initial operation in the LIGO

Two conceptual designs for a 4 km Michelson delay line receiver to meet the initial goals of the LIGO have been analyzed and an analytic model has been developed to estimate the contribution of known noise sources (Appendix G). The design study has identified components that would need development should such a receiver be constructed. These are large aperture (15 cm) electrooptic modulators, large diameter single mode optical fibers and long focal length, 87 cm diameter mirrors. Mirror specifications (substrate material, surface polish, figure and slope errors) have been developed with industry. Ray trace analysis has been performed on delay line configurations using separate input and output coupling holes to determine sensitivity to mirror distortion and fringe phase changes due to motions transverse to the optic axis. The design of a 5 meter prototype based on one of the conceptual designs has been completed.

c) Selection of prime receiver

The Fabry-Perot receiver system has been selected as the prime instrument for the initial LIGO operations (see Section VII) and will be the focus of LIGO receiver development both at the 40-meter and the 5-meter prototypes. The delay-line system will be maintained as an alternate and backup to the Fabry-Perot.

4. Scientific analyses to set the requirements of a 4 km facility

A complete calculation of scattering by residual gas in the LIGO has been made. This calculation confirms earlier estimates of the vacuum requirements.

Preliminary calculations of scattering by mirrors and tube walls have been made to determine a baffling strategy for the LIGO. The initial results indicate that scattering by tube walls and baffles driven by ground motion will not be a concern at frequencies above 100 Hz and probably will not be a serious problem at lower frequencies. More extensive (and difficult) calculations are needed to firm up our conclusions in the low frequency regime.

5. Development of a technique to measure small angle scattering

The system shown in Figure V-12 was developed, using fiber optics, to investigate the scattering around the focus of a spherical mirror when the surface is illuminated by a gaussian laser beam. At present, the system measures scattering as close as 800 microradians to the specular direction. The system has application to tests of large baseline mirrors; and its results have been an important input to our calculations of scattering effects in the LIGO (see above).

D. Collaborative Efforts

The following collaborative efforts with other researchers were established:

- 1) Prof Dan de Bra, Stanford University—work on magnetic suspension systems; mode: exchange of analysis and data.
- 2) Prof Neil Comins, University of Maine, (Orono, ME)—work on data analysis algorithms; mode: exchange of ideas and software.

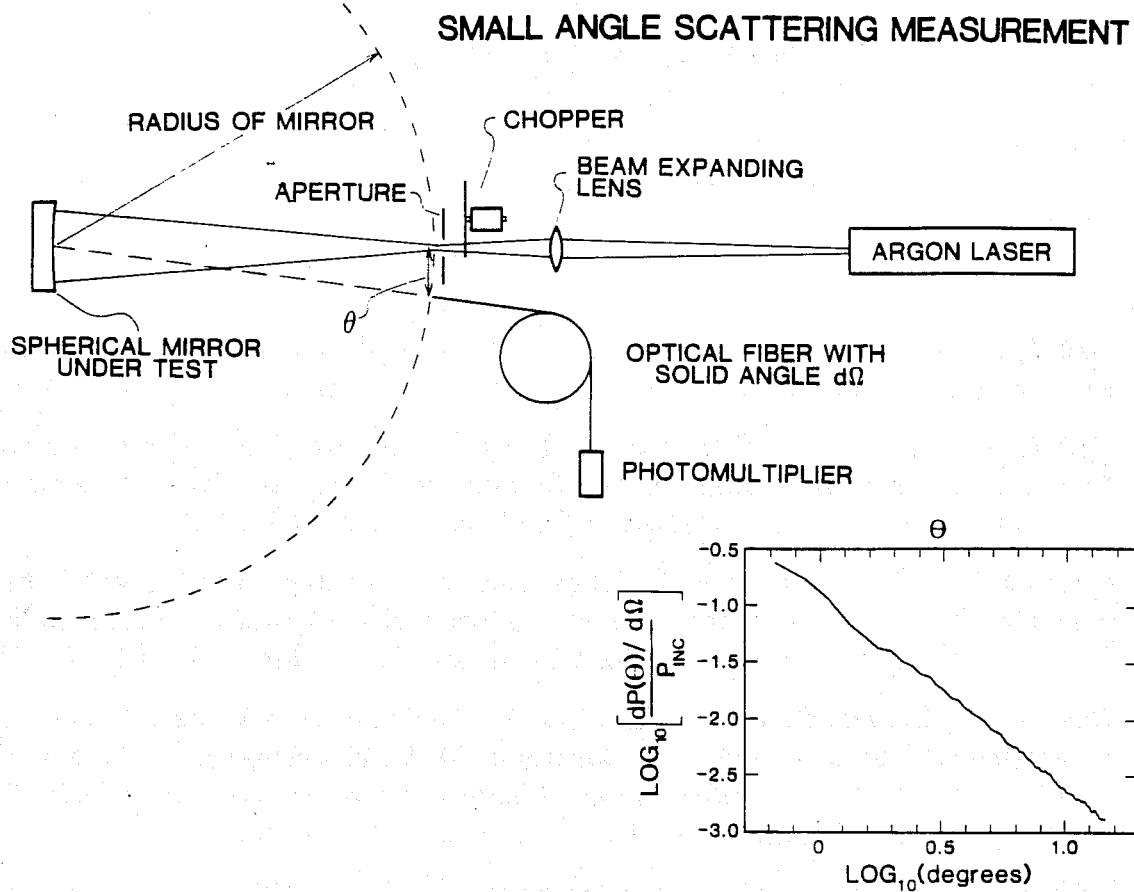

Figure V-12: A technique to measure small angle scattering. The technique has been developed to measure the small angle scattering of spherical mirrors in the laboratory. The curve in the lower right hand corner is the scattering function for one of the mirrors used in the 1.5-meter prototype.

- 3) Dr J.Chernoch, General Electric Research Laboratories, Schenectady, N.Y.—work on slab zig-zag Nd:YAG laser oscillators and amplifiers; mode: cooperative program to study properties of GE slab laser for application to gravitational wave research. GE has lent the LIGO project a slab laser for tests, and GE is testing most recent version of slab laser in single radial mode.
- 4) Dr. A. Mooradian, MIT Lincoln Laboratory—work on diode pumped oscillator and amplifier, Nd:YAG laser, ; mode: exchange of information and access to unclassified technology at Lincoln.
- 5) Dr. R. Schilling, Max Planck Institute, Garching, Germany— work on recycling of light with internal interferometer phase modulation (paper with NSF acknowledgement in preparation); mode: visitor to MIT April 1987 to October 1987.
- 6) Dr. H. Ward, Glasgow University—work on automatic cavity alignment system; mode: several extended visits to Caltech.

E. RECENT BIBLIOGRAPHY

NSF GRANT PHY-8504136

NSF GRANT PHY-8504836

The following is a list of publications and presentations since 1985, supported wholly or in part by the above grants.

1987:

Čadež, A., Abramovici, A. "Measuring High Mechanical Quality Factors of Bodies Made of Bare Insulating Materials", *J. Phys. E: Sci. Instr.*, (1987), in press.

Čadež, A., Harman, J. "Electrostatic Forces in Gravity Wave Interferometers", Prepared for the *Proceedings of the International Symposium on Experimental Gravitational Physics, Guangzhou, P. R. China, August 3-8, 1987.*

Chen, Y-T. "The Measurement of Gravitational Constant and Recent Developments in China", Prepared for the *Proceedings of the International Symposium on Experimental Gravitational Physics, Guangzhou, P. R. China, August 3-8, 1987.*

Chen, Y-T., Drever, R.W.P. "Reduction of Seismic Noise in a Laser Gravitational Wave Detector by Interferometer Control of Test Mass Suspension Points", Prepared for the *Proceedings of the International Symposium on Experimental Gravitational Physics, Guangzhou, P. R. China, August 3-8, 1987.*

Dewey, D. "Comparison of Bar and Interferometer Sensitivities to Sources of Transient Gravitational Radiation", *Phys. Rev. D***36**, 1577, (1987).

Dewey, D. "Data Analysis as a Noise Diagnostic: Looking for Transients in Interferometers", In *Proceedings of the 1987 NATO Advanced Research Workshop on Gravitational Wave Data Analysis*, ed. B. Schutz, (1987), in press.

Dewey, D. "Comparison of Bars and Interferometers: Detection of Transient Gravitational Radiation", In *Proceedings of the 1987 NATO Advanced Research Workshop on Gravitational Wave Data Analysis*, ed. B. Schutz, (1987), in press.

Drever, R.W.P., Spero, R., Chen, Y-T., Čadež, A., Abramovici, A., Gürsel, Y., Zucker, M., Smith, S., Bostick, A., Ward, H. "Developments in Laser Interferometer Gravity Wave Detectors", prepared for the *Proceedings of the International Symposium on Experimental Gravitational Physics, Guangzhou, P. R. China, August 3-8, 1987.*

Jeffries, A., Saulson, P., Spero, R., Zucker, M. "Gravitational Wave Observatories", *Scientific American*, **255**, 50-60, (June 1987).

Livas, J. "Broadband Search Techniques for Periodic Sources of Gravitational Radiation". In *Proceedings of the 1987 NATO Advanced Research Workshop on Gravitational Wave Data Analysis*, ed. B. Schutz, (1987), in press.

Saulson, P., Benford, R., Burka, M., Christensen, N., Eisgruber, M., Fritschel, P., Jeffries, A., Kovalik, J., Linsay, P., Livas, J., Weiss, R. "Progress on the MIT 5-Meter Interferometer", prepared for the *Proceedings of the International Symposium on Experimental Gravitational Physics, Guangzhou, P. R. China, August 3-8, 1987*.

Smith, S. "Algorithm to Search for Gravitational Radiation From Coalescing Binaries", *Phys. Rev. D* **36**, 2901-2904, (1987).

Weiss, R. Bender, P., Berlad, A., Donnelly, R., Dyson, F., Fairbank, W., Homsy, G., Langer, J., Naugle, J., Pellat, R., Reynolds, J., Ruffini, R., Saville, D., Schrieffer, J. "Task Group on Fundamental Physics and Chemistry", *National Academy of Sciences Report on Gravitational Physics*, (1987).

1986:

Dewey, D. "Analysis of Gravity Wave Antenna Signals with Matched Filter Techniques", *Proceedings of the Fourth Marcel Grossman Meeting on General Relativity*, Elsevier, Amsterdam, 581, (1986).

Livas, J., Benford, R., Dewey, D., Jeffries, A., Linsay, P., Saulson, P., Shoemaker, D., Weiss, R. "The M.I.T. Prototype Gravitational Wave Detector", In *Proceedings of the Fourth Marcel Grossman Meeting on General Relativity*, Elsevier, Amsterdam, 591, (1986).

Saulson, P., Benford, R., Burka, M., Christensen, N., Eisgruber, M., Fritschel, P., Jeffries, A., Kovalik, J., Linsay, P., Livas, J., Weiss, R. "Interferometric Gravitational Wave Detection at MIT", *13th Texas Symposium on Relativistic Astrophysics*, ed. M. Ulmer, Singapore: *World Scientific*, 15, (1986).

Spero, R. "The Caltech Laser-Interferometric Gravitational Wave Detector", In *Proceedings of the Fourth Marcel Grossman Meeting on General Relativity*, ed. R. Ruffini, 615-620, (1986).

1985:

Hoskins, J., Newman, R., Spero, R., Schultz J. "Experimental Tests of the Gravitational Inverse-Square Law for Mass Separations from 2 to 105 cm", *Phys. Rev. D* **32**, 3084-3095, (1985).

Ward, H., Hough, J., Newton, G., Meers, B., Robertson, N., Hogan, S., Kerr, G., Mangan, J., Drever, R.W.P. "Laser Interferometric Sensing Techniques for Very Small Displacements - with Applications to Gravitational Radiation Detectors" *IEEE Trans. Instr. Meas.* **IM-34**, 261-265, (1985).

Articles in preparation:

Dewey, D., Livas, J., Weiss, R. "Noise Due to Scattered Light in Interferometric Gravitational Antennas and Its Reduction by Random Phase Modulation of the Input Beam".

Gürsel, Y., Linsay, P., Saulson, P., Spero, R., Weiss, R., Whitcomb, S. "Response of a Free Mass Interferometer Antenna to Gravitational Waves".

Schilling, R. "Recycling with Internal Modulation".

Weiss, R. "Analysis of a Multipass Interferometer Using Tagged Light Beams and a Compact Geometry for Gravitational Wave Research".

F. Relation of Completed Work to Proposed Work

The proposed 3-year program (see Part VI) is a direct continuation of the R&D program supported under the present grant arrangement between NSF, Caltech, and MIT. The goals of a long range development program towards the LIGO were established at the time of our last proposals, three years ago, and remain unchanged. Administratively, a change from a loose association between the Caltech and MIT science teams to a unified program under a Project Director has recently been implemented.

Prototype development in the 40-meter facility, both to improve the sensitivity and to develop the receivers for a longer baseline system, will continue. The partially completed 5-meter system will be brought on line. The work on high power lasers, both argon and Nd:YAG systems, will grow. The research on the 1.5 meter prototype will phase out during 1988 after the current research on a fiber output coupler is completed. The most significant change in the experimental program is that the effort to develop a Michelson delay-line system as a receiver for the LIGO will be deferred so that the entire research group's energy can be applied to the development of the Fabry-Perot receiver system.

Work on the design, engineering and cost estimation of the LIGO will continue. During the next six months the conceptual design and functional requirements of the observatory will be completed preparatory to a proposed preliminary engineering design task in industry. Work will continue to establish primary and secondary sites for the observatory.

VI. PROPOSED WORK

This section describes the work that we plan to carry out during the three years of this proposal.

A. Receiver Development

The principal goal of the receiver development program is to establish the basic design for the first pair of LIGO receivers. The design will be established in sufficient detail to permit the final design, engineering and construction to begin at the end of the proposed grant period. A secondary goal is to carry out research on new concepts and techniques that will enhance the sensitivity and frequency coverage of LIGO receivers. The two goals have substantial overlap in that, within the constraints of maintaining reliability and minimizing the uncertainty in the extrapolation from prototype to LIGO scales, the initial receiver will be the most sensitive configuration we can design at the end of this grant period.

Receiver development will be a coordinated program of the Caltech and MIT Science Teams and the LIGO Engineering Section, using the 40-meter and 5-meter facilities. The Fabry-Perot system has been chosen for the first operational receivers in the LIGO.

The proposed receiver work is roughly divided into three areas:

First, the continuation of ongoing research to improve the performance of the prototypes. The prototypes will be the basis for the initial LIGO receiver and will offer the best means to uncover problems in overall receiver concepts. Substantial effort will be made to improve the laboratory facilities for the prototypes so as to make the research more efficient and to permit testing of the prototypes using full-size LIGO-scale receiver components.

Second, the development of techniques that are needed to achieve the aimed-for sensitivities in the LIGO, but are not necessarily related to direct improvements in prototype sensitivity. Some parts of this work will be carried out on the prototypes, and other parts in separate laboratory facilities.

Third, the analysis, modeling, and experimental testing of critical aspects of the LIGO receiver components and receiver/facility interface, with emphasis on aspects that could be influenced by the scaling from the prototype to LIGO dimensions.

We shall now discuss these three areas of research in detail.

1. Improving Prototype Receiver Sensitivity.

The receivers described in Part V have been developed to a sophisticated level. In the last 5 years the sensitivities of successive versions of Fabry-Perot receivers in the 40-meter vacuum system have been improved by more than 3 decades in amplitude—a flux sensitivity improvement of nearly 10 million times. As a result, this instrument, in its present prototype form, is within a factor three in sensitivity of the more mature cryogenic bar gravity-wave detectors, while having enormously greater bandwidth.

In spite of these achievements, our ultimate goals require major further improvements in receiver sensitivity. The development of advanced receivers involves a judicious mix of analytical and intuitive skills. These skills are in ample supply on the two science

teams of the project, and it is the Director's responsibility to ensure that they are used most effectively. In general, effective receiver development requires operation of the best possible prototype instrument at every stage, since the relative magnitudes of predicted or "discovered" effects cannot be determined, and solutions developed, with any less sensitive apparatus. Thus, the step-by-step quest for better sensitivity in both the 40-meter and 5-meter prototypes will remain critical to receiver development. Among the already identified new tasks, for which detailed planning has started, are these:

(a) Modifications of Argon Lasers to Achieve Higher Power.

The argon ion lasers now in use (Coherent Innova 100-20) are the most powerful lasers of their type commercially available. Their single-mode output is rated at five watts; the two lasers in the 40-meter facility were selected for high power, and have been tested at 7 watts single mode. The method used to stabilize the laser, adjusting its wavelength with an intra-cavity Pockels cell, reduces the maximum output power to 2 watts. The highest quality Pockels Cells exhibit losses on the order of 1% per pass, and their lifetime is limited by radiation damage.

The Pockels cell used to stabilize the laser will be replaced by a fast-response piezo-driven mirror. The servo bandwidth attainable with a moving mirror is limited by sound-speed propagation delays to approximately 200 kHz, significantly less than the bandwidth achievable with a Pockels cell. To recover lost high-frequency response an external Pockels cell will be used to correct residual short-term phase fluctuations, as demonstrated at JILA [VI-1] and already applied to gravity-wave detectors [VI-2], including the 40-meter prototype.

(b) Development of beam recombining interferometers.

The basic arrangement for a gravity-wave detector using recombined Fabry-Perot cavities is illustrated in Figure VI-1. Here a beamsplitter divides the laser beam into two equal parts that pass via Pockels cell phase modulators PC1 and PC2, driven in antiphase with one another by a radiofrequency generator, to optical cavities formed between low-loss mirrors. A small fraction of the light coming back out of each cavity is diverted to auxiliary photodiodes (D2 and D3) by slightly reflecting mirrors shown as dashed lines in the diagram. Signals from these diodes are coherently demodulated (as described in Appendix H) to provide measurements of the phase differences between the laser light and the light resonating within each cavity. These phase differences may be used to stabilize the frequency of the laser, and also to feed back a length correction to each cavity to maintain it in resonance with the light. Most of the light emerging from the cavities is not diverted, but instead returns to the beam splitter, which recombines the two beams. The diode D1 monitors the recombined light, providing a direct measurement of the phase difference between the output light from the two cavities; this is the main interferometer output.

The Fabry-Perot cavity interferometers used to date have been similar in principle, but not identical to this arrangement. One simplification has been to divert all the output light from the cavities to the diodes D2 and D3, and use their signals not only for feedback control but also as the main interferometer output. (This is the system described in Part V, Figure V-4.) Thus, the modulators PC1, PC2 and photodiode D1

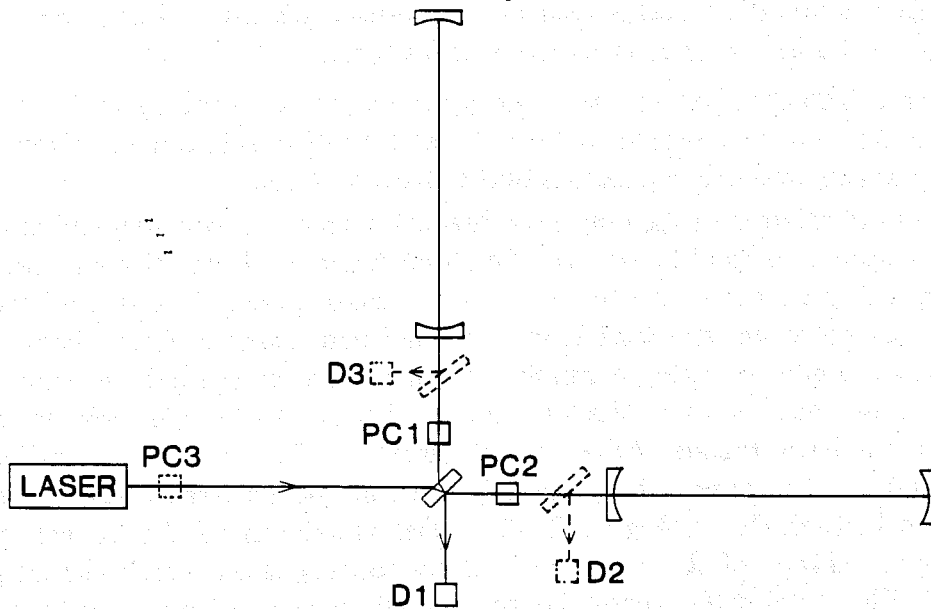

Figure VI-1: Simplified diagram for a beam recombining Fabry-Perot interferometer.

in Figure VI-1 have not yet been installed. With the experience we now have in the operation and precise position control of optical components in vacuum, we plan to rebuild the 40-meter Fabry-Perot prototype as an optically recombining interferometer system early in our program. Figure VI-1 is schematic in the sense that several techniques to achieve optical recombination in a Fabry-Perot will be analyzed. A particularly interesting variant is shown in Figure VI-2 where the RF phase modulation is achieved by placing the modulator in an auxiliary arm of the interferometer to reduce the optical power in the Pockels cell. The beam recombination feature will be implemented in the 5-meter system from start-up of operations as a Fabry-Perot prototype.

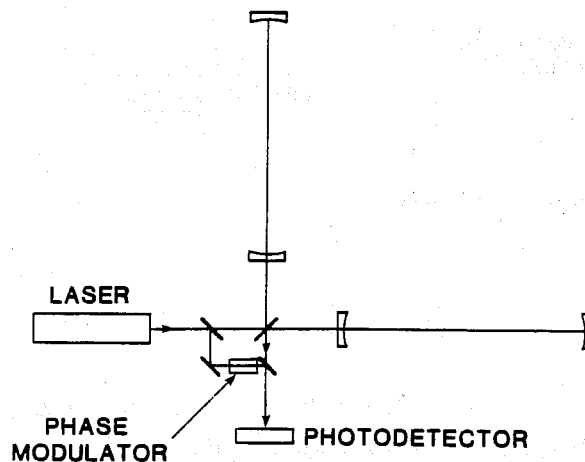

Figure VI-2: Beam recombination with auxiliary arm.

(c) Development of Techniques for Automatic Optimization of Beam and Mirror Alignment, and other Autonomous Control Systems.

Another improvement in the prototypes we intend to carry out early in the program is the further development of techniques for automatic optimization of beam and mirror alignment, and other autonomous control systems.

The cavity mirrors in the long-baseline interferometers are suspended freely so that they may respond to gravity waves. The alignment of these mirrors and of the laser beams impinging on them has to be precisely maintained. In current interferometers this is done by servo systems that sense the alignment using optical levers and position-sensitive photodiodes or using a number of capacitive or optical position sensors, and then apply feed-back forces to the test masses through the suspension wires or by electrostatic or magnetic means. An automatic method of optimizing the adjustments has been devised in the course of developing the Fabry-Perot receivers. The technique, illustrated schematically in Figure VI-3, senses misalignment by an extension, to geometrical parameters, of the reflection-locking technique on which the interferometers are based. The system measures the gradient in phase difference between light from the cavity and laser light reflected from the input mirror, at two planes in the output beam. The errors in alignment or position are processed to give correction signals that adjust the orientation of the mirrors or the position and direction of the laser beam.

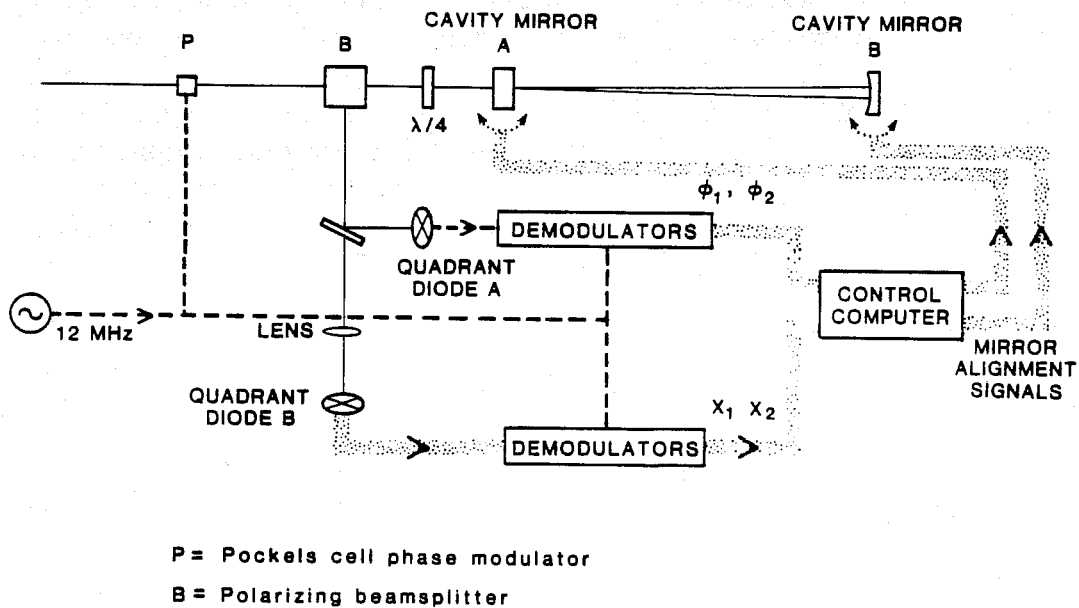

Figure VI-3: Method for automatic optimization of mirror alignment.

Successful operation of this system has been demonstrated in the 40-meter interferometer [Section V-B-1(c) above], and further development is in progress to make the automatic system switch back to a non-automatic mode that maintains alignment during periods when the cavity may be out of resonance. We plan extensions of this system

to many other parts of the interferometer, supplemented by further control systems capable of maintaining accurate adjustment of all critical parts of the interferometer. This will be a continuing development, over a long period, and it is likely to improve the performance of the prototype interferometers, and also to become an important part of the LIGO receivers.

2. Development of Techniques Required to Achieve the Aimed-for Sensitivities in the LIGO.

(a) Laser light sources.

Desirable properties of lasers for both prototype and LIGO receivers include:

1. High power, continuous-wave output in a single transverse and longitudinal mode. Pulsed operation could be acceptable if the mean power is high, the repetition rate is at least 10 kHz, and optical phase coherence can be maintained from one pulse to the next. The goal for the initial LIGO receivers is 100 watts. This can be reduced to 10 watts if light recycling is used [subsection (b) below].
2. The output beam profile should be as close as practicable to that of a pure Gaussian mode, or have an amplitude profile that can be efficiently transformed into such a mode. This is required to allow efficient matching into optical cavities and other systems.
3. Optimal wavelength. A laser capable of generating light of short wavelength is desirable for two reasons: the power needed for a given shot-noise limited sensitivity is proportional to the wavelength (equation A-21, Appendix A); and the dimensions of mirrors and other optical components—and thus the diameter of the beam pipes—scale as $\lambda^{1/2}$. Thus, the cost of the installation is reduced by shortening the wavelength. However, the wavelength must be consistent with the availability of low-loss mirrors and efficient photodetectors. Frequency multiplying may be an effective way of obtaining short wavelength lasers from energy-efficient longer-wavelength lasers, such as diode-pumped Nd:YAG lasers.
4. A long term goal is that the laser efficiency for conversion of input power to useable light power should be as high as possible. This requirement reduces operations costs for the LIGO when the number of interferometers operating simultaneously is large, as it affects the power and cooling demands.
5. The lasers must be reliable and not incur unreasonably high costs in replacement parts.

Because the laser is such a critical component in the project, we intend to maintain a dual program in laser development consisting of the refinement of the argon laser system as well as the development of the Nd:YAG.

(a-1) Addition of Argon Lasers

A single argon ion laser, even operating at full power, is not adequate to achieve the best projected sensitivity of the LIGO receivers, especially at frequencies greater than 1 kHz. A method for stabilizing several lasers to a reference cavity and summing their outputs has been devised, and will be tested during the proposed period. Figure VI-4 shows the optics and electronics used to add two lasers coherently. The ultimate system will sum at least four lasers. In addition to providing more output power, the use of several lasers will add reliability to the detector—the failure of one laser will not halt operations.

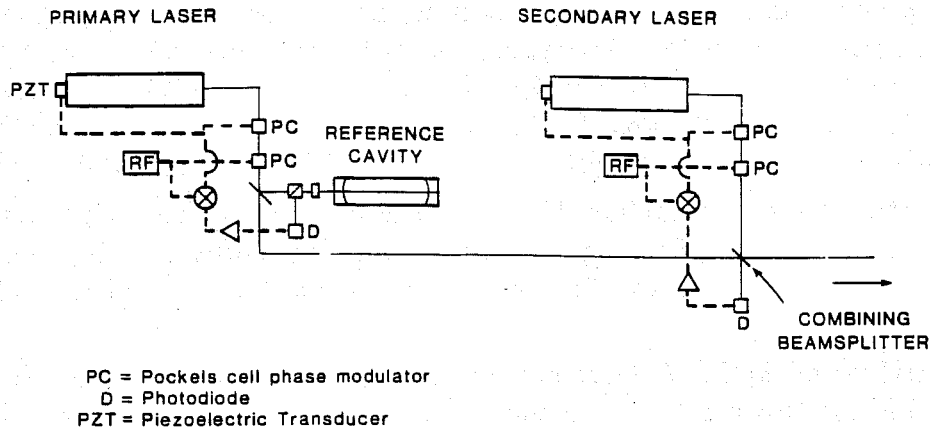

VI-4: A method to increase optical power by coherent addition of lasers.

(a-2) Nd:YAG Laser Development.

The major advantages of the Nd:YAG system are its relatively high efficiency, \approx 1 to 5%, its high output power, and its low intrinsic frequency noise and low amplitude noise at RF frequencies.

Cooperative arrangements link the LIGO project with ongoing high-power Nd:YAG laser and amplifier research programs at General Electric and at the MIT Lincoln Laboratory. Stabilizing the frequency and amplitude of the laser is the basis of our proposed work during this grant period.

The laser system we intend to develop is shown in Figure VI-5. It consists of a primary diode pumped ring oscillator developed by Prof. R. Byer [VI-3] at Stanford. The oscillator is followed by a diode pumped amplifier. Recent progress and near-term projected advances in diode laser pump technology indicate that within the next year it should become possible to construct diode pumped amplifiers with the capability of delivering a few watts. An amplifier with 60 db gain (using flash lamps) has been demonstrated [VI-4]. In present plans the final stage will be a GE slab head pumped by lamps, but the final stage might be diode pumped if the laser diode program continues to advance at the projected rate. The frequency of the master oscillator is stabilized by reference to a cavity using the reflection technique developed for the argon laser system.

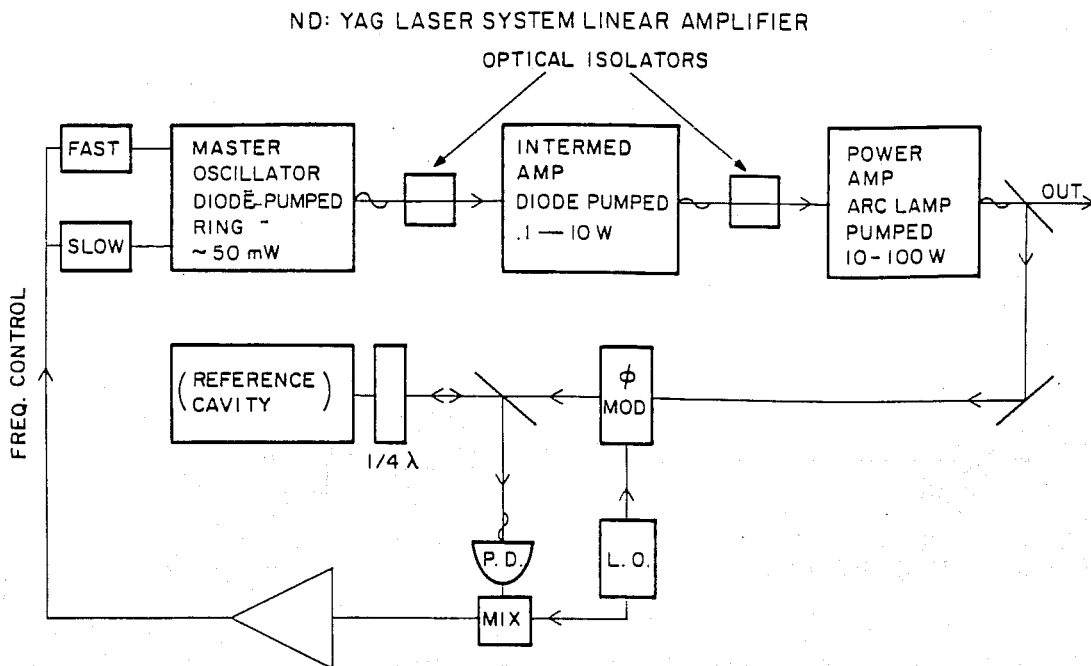

Figure VI-5: Schematic of the proposed frequency-stabilized Nd:YAG oscillator/amplifier combination.

(b) Experimental development of Light Recycling and Optically Resonating Receiver Techniques.

Advanced receivers in the LIGO will almost certainly use “light recycling” or “optically resonating”; and even the initial receiver might use recycling.

Light Recycling [VI-5] exploits the fact that our present Fabry-Perot mirrors have such low optical losses that light can be stored for periods up to a millisecond in the 40-meter cavities; and correspondingly longer storage times are possible in a kilometer-scale system. Once the storage time has reached half the gravity-wave period, however, further increases in storage time do not produce much improvement in the photon shot noise limit to sensitivity. Thus, in a LIGO-scale Fabry-Perot interferometer it would be convenient to choose the transmission of the input cavity mirrors to make the storage time approximately half the gravity-wave period. With so short a storage time, most of the input light would return back from each cavity to the beamsplitter. It is convenient and efficient to arrange that the output photodiode is at a dark region in the interference pattern, with the high frequency phase modulation giving a small phase dither around the minimum-intensity point. Under these conditions most of the light leaves the system through the other side of the beamsplitter. It then becomes possible to re-use this light, by returning it to the interferometer in the correct phase to reinforce the input laser light. This return can be achieved by an additional mirror in front of the laser. This “broadband recycling system” is shown, in principle, in Figure VI-6a. The sensitivity improvement achievable by this arrangement depends on the length of the interferometer arms and the mirror losses (equation A-24a in Appendix A), and is

indicated in Figures II-2 and A-4a by the right hand part of the curve labelled "possible advanced detectors".

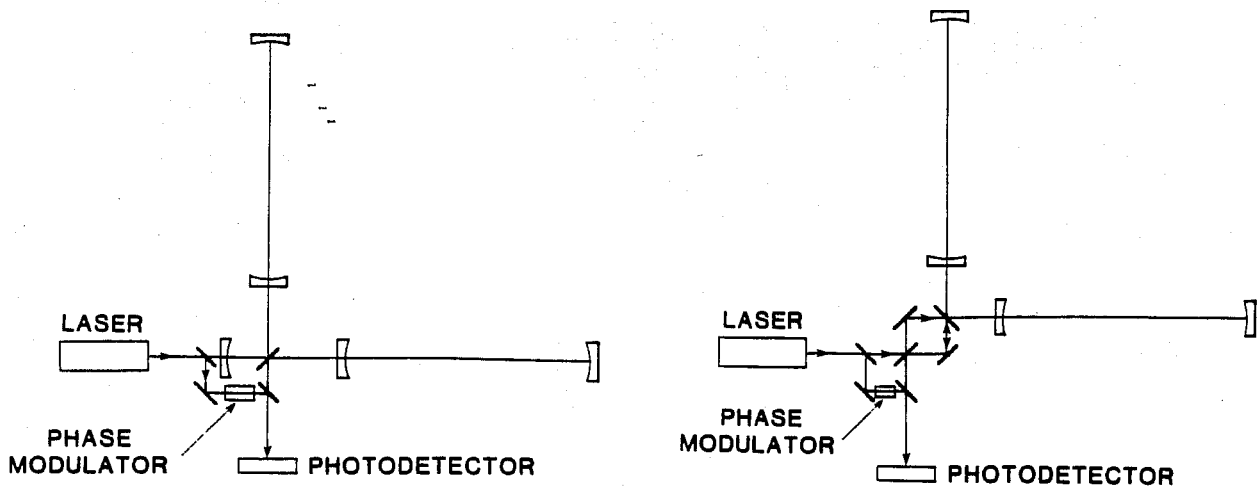

Figure VI-6a,b: VI-6a (left); broadband recycling system. VI-6b (right); optically resonating system.

Optically Resonant Recycling [VI-6] is applicable in the detection of periodic and stochastic gravity waves. The optical arrangement, as illustrated in Figure VI-6b, involves coupling the two optical cavities to one another via a mirror of high reflectivity, which takes the place of the usual beamsplitter. The coupled cavities then have two main resonance modes, one of which is arranged to correspond to the frequency of the laser light, and the second to a sideband produced by modulation of this light at the gravity-wave frequency. A continuing periodic gravity-wave can build up a signal in this second mode during the overall light storage time—which may be many gravity-wave periods—to give a much enhanced response. Detection of the resonant phase signal may be made by the auxiliary interferometer shown at the lower left of the main system. This "optically resonant" receiver gives a larger enhancement in sensitivity at its resonant frequency than the broadband recycling system; but it does so at the price of a narrowing of the bandwidth. Expressions for its shot noise limits to sensitivity are given in equations (A.24b, c) of Appendix A and are illustrated in Figures A-4b and A-4c.

Light recycling and optical resonating are planned for the LIGO, but in the 40-meter prototype the currently available mirrors do not give long enough storage times for recycling or resonating to be useful at frequencies $f \leq 1$ kHz. We propose, during this grant period, to test and develop recycling. We may do so at frequencies higher than 1 kHz so as to partly compensate for the difference in storage time between the prototype and the full-scale LIGO system.

In addition to light recycling and resonating, there is a third technique that shows promise for advanced receivers: the use of "squeezed light" in the interferometer [VI-7]. We do not plan to work on this during the proposed grant period, but will likely pursue it in the more distant future.

(c) Test Masses and Mirrors

(c-1) LIGO Test Masses

A lesson learned early in the development of prototype receivers is the critical nature of the test masses, especially their spectrum of mechanical vibrations. The design criteria for test masses are:

- Minimum thermal noise. Internal vibrations, including the inescapable thermally excited modes of energy $\frac{1}{2} kT$, threaten to mask signals. Thermal noise is minimized by
 1. Selecting materials and construction techniques for high mechanical Q.
 2. Keeping the lowest resonant frequency well above the gravity-wave signal band.
 3. Maximizing the mass, within the constraint of high resonant frequencies. This will also reduce the quantum limit (equations A-25 in Appendix A) and the effects of fluctuating forces of residual gas molecules..
- High optical purity. The test masses at the interferometer input must be transparent; and their optical properties are critical in recycling applications: the material must be low in optical loss, optical inhomogeneity, and scattering.
- Surfaces that will accept a super-polish finish and ultra-low loss optical coatings.

The test mass material currently used in the 40-meter prototype, fused silica, has high mechanical Q [VI-8] and is commonly used as a substrate for high quality optics. Pieces roughly double the linear dimension of the present masses in the prototype will serve in LIGO receivers optimized for 1 kHz and above. We propose during this grant period to acquire fused silica masses of this size (20 cm diameter by 10 cm thick), verify that their mechanical and optical losses are low, and eventually install them in interferometers. We will also investigate sapphire as a candidate test mass. Its mechanical properties are unsurpassed [VI-9] and early experiments [VI-10] indicate it may be an excellent substrate for low-loss optics.

(c-2) LIGO Mirrors

Mirrors reside at the heart of a gravity-wave receiver, and their properties determine the receiver's ultimate sensitivity and frequency range. Desirable properties of the mirrors are:

- Low loss. The mirrors installed in the 40-meter prototype have scattering and absorption losses in their dielectric coatings small enough to optimize sensitivity for signals at 500 Hz and above. Similar mirrors installed in a 4-km interferometer will extend the frequency range downward and permit enhancing the sensitivity by recycling.
- Capability to withstand high power. The power incident on the main cavity mirrors in a LIGO receiver will be spread over a large enough area that heating damage is unlikely, even at the highest projected power levels. The still higher intensities incident on auxiliary cavities will be managed by using mirrors with low

absorption loss and by decreasing the intensity of the resonant light—this can be accomplished without reducing the useable power by building the cavities several meters long.

- **Low scattering.** The interferometer mirrors are likely to be the dominant source of scattered light. This potential source of noise may be reduced by using mirrors with the same low scattering loss as the mirrors currently used in prototype research.

The Project has entered a contract with the Guidance and Control Division of Litton Industries, to supply mirrors for receiver development. We have worked in close cooperation for several years with their internal research and development group and have received from them custom-coated prototype mirrors with losses as low as 40 parts per million. We have devised methods previously unavailable in the industry [VI-11] for testing the mirrors, and we expect this collaborative arrangement to result in still better mirrors as the testing and production techniques are refined to fit the LIGO requirements. During the grant period we will acquire from Litton ultra-low loss mirrors of 12 cm diameter, and test them in the prototypes. This size mirror can be coated in existing chambers at Litton without extensive retooling, and it is an appropriate size to serve as the test-mass mirror for the LIGO midstations. Because, however, it is probably too small for the full-length interferometers, we will investigate contracting for modifications to existing coating chambers to produce larger mirrors.

(d) Seismic Isolation Development Toward Lower Frequencies.

The seismic isolation demonstrated in the prototypes (Part V, Figure V-5) is adequate for the first receiver in the LIGO at kHz frequencies. There are, however, important reasons to continue the development of improved seismic isolation, especially at low frequencies. These are:

1. The expectation that the probability of detecting sources is higher at lower frequencies.
2. Improved isolation has multiple benefits in the prototype research by reducing the dynamic range required of servo controllers, and reducing upconversion by nonlinear couplings in the suspensions and the fringe noise from parasitic interferometers.

We propose to continue work on a dual approach to the problem. One part is local isolation, with multiple vibration isolation systems at each suspended element; the other is global isolation for the important degree of freedom along the optic axis of the interferometer. The two methods are complementary, and both are also adaptable to active isolation systems which will be needed to achieve the ultimate low frequency performance of the LIGO.

(d-1) Description of the Anti-Seismic Suspension Point Interferometer

Global isolation along the optic axis will be introduced, during the proposed grant period, using a suspension-point interferometer on the 40-meter prototype. Already about half completed, this instrument incorporates two unequal-arm Michelson interferometers to sense relative motions of the suspension points for the mirrors at the

two ends of each arm (Figure VI-7). At frequencies below 100 Hz, the seismic noise feeding through the suspension wires dominates other noise by a large factor. Moreover, at frequencies above 1 Hz the suspension point moves more than the test mass below. Therefore, even a relatively low-sensitivity single-bounce interferometer can provide useful suspension-point signals. The signals will be fed back to piezoelectric translators near the points of suspension, reducing seismically-induced relative motions of the suspension points as much as 100-fold. Because of the isolating effect of the wire suspensions, reduction of this seismic noise will not affect the gravity wave signal as measured at the test masses.

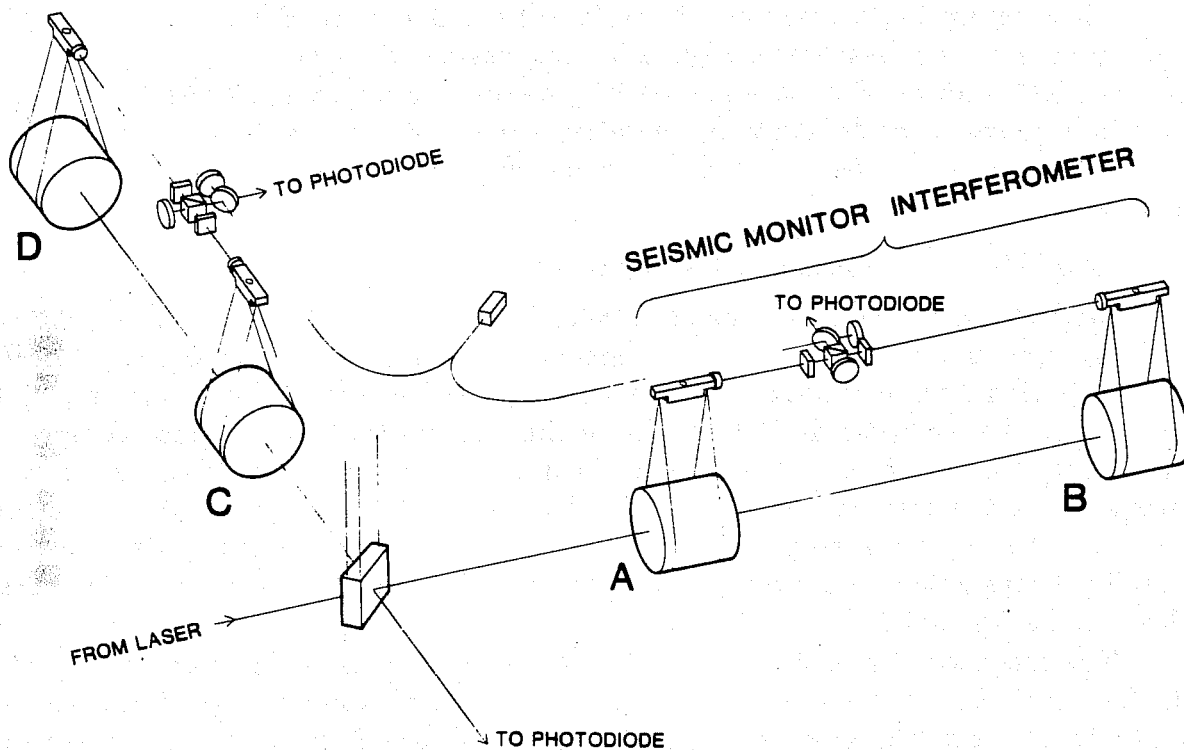

Figure VI-7: Anti-Seismic Suspension Point Interferometer.

(d-2) Multiple Suspension Development

Local isolation at frequencies below 1000 Hz will be improved during the proposed grant period. To bring the seismic noise at a remote site to a level comparable to the other noise terms projected for the initial sensitivity of the LIGO requires a total isolation of 200 db at 10 Hz and 160 db at 100 Hz. No single stage system is expected to be able to provide this degree of isolation. However, it should be attainable using multiple vibration isolation systems which, as one advances toward the mirror, exhibit progressively less thermal noise. In the simplest systems, the isolation just comes from the passive action of masses and springs, although in practice it is usually necessary to use active feedback to damp their resonances. More advanced designs will use servos to improve the isolation by locking the motion of an outer mass in the hierarchy to

that of an inner one, thereby lowering the effective resonant frequency. Although vibration isolation along the optical beam direction is the most critical, cross coupling and imperfections in the alignment of the interferometers argue for nearly isotropic isolation.

A prototype of a new suspension system for the mirrors of an interferometer is now under construction for the 5-meter system (Part V, Figure V-9). The principal aspects of the design strategy are 1) to provide several stages of passive isolation in a cascade of mechanical resonators, including a substantial amount of isolation for the degrees of freedom transverse to the optical axis, 2) to make the mirror itself the final isolated mass in the cascade, 3) to use active (cold) damping for all degrees of freedom, and 4) by servos to achieve active reduction of resonant frequencies (active isolation).

This suspension, before installation in the prototype interferometer, will undergo tests in an auxiliary chamber designed for suspension research which is a new facility for the LIGO project. Subsequent work will be done to improve the suspension design with measurements of damping in pendulum wires under stress and with tests of new sensors and actuators, vacuum compatible passive isolation stacks, and active isolation servo loops.

(d-3) Magnetic Suspension Development

Magnetic suspensions are being developed as an outer stage of a local, multiple isolation system. The properties of a magnetic suspension that make it interesting for gravitational wave research are: 1) they are well suited to high vacuum, 2) the spring (i.e. the magnetic field) has none of the internal resonances which compromise the isolation of mechanical springs, 3) one can attain long periods, of the order of 100 seconds, in a compact geometry. The disadvantage is the low Q due to eddy current losses and it is for this reason that (until room temperature superconductivity becomes a reality) magnetic suspensions must be followed by a high Q suspension to act as a filter for thermal noise.

The magnetic suspension now under development is shown in Part V, Figure V-10. It is intrinsically stable for motions in the horizontal plane with oscillation periods determined by the field geometry. The support forces are provided by permanent magnets trimmed by coils driven through a servo system to achieve stability for vertical translation and for rotations about axes in the horizontal plane. The system has been floated and supports 150 kg using three Alnico magnets. When completed and tested successfully, the system will be incorporated as the first stage of isolation in the 5-meter prototype.

(d-4) Interferometric Fiberoptic Position Sensor

One candidate system for standardized production by the LIGO project is a fiberoptic position transducer that will find application in passive and active vibration isolation systems. A schematic of the transducer is shown in Part V, Figure V-11. The position sensor is a phase modulated Michelson interferometer. An operating prototype has been developed that uses a 1 milliwatt laser diode at 1.3 microns. The electronics is designed to give both analog signals within a single fringe and digital information for fringe counting to accommodate large motions.

The measured position sensitivity of the detector using a multi-mode laser is at

present 2×10^{-11} m/ $\sqrt{\text{Hz}}$. With a single mode diode laser, the system should have a sensitivity of 2×10^{-14} m/ $\sqrt{\text{Hz}}$ and a larger dynamic range. A distributed feedback diode laser will be tried within the next year.

3. Analysis, Modeling and Experimental Study of Aspects of the LIGO Receivers that are Difficult to Test at Prototype Scale.

Extensive analysis has been carried out to determine the sensitivity scaling properties of interferometric gravitational wave detectors from small to large baselines for fundamental noise terms (See, e.g., Reference [III-5]). The analysis has been used to determine the essential properties of the LIGO (see Part IV.C).

In going from the present prototype experiments to the LIGO, some parameters in the experiment design and some noise terms uncovered in the implementation of the receivers will change with the scale. In particular, the optical beam size and delay times of signals grow, while the relevant angles for alignment, diffraction and scattering decrease. The analysis of the influence of these scale changes needs more work and this is proposed as part of a combined analytic and experimental program during this grant period. There are several important areas.

(a) *Mirror Scaling and Scattering.*

The mirrors for the LIGO will be larger than in the present prototypes. Coating uniformity, surface roughness, surface figure and slope error, substrate transmission and wavefront distortion, the internal mechanical losses and resonant frequencies, and the thermal properties of the mirrors all depend, to varying degree, on mirror size.

The influence of scattering by mirrors as a function of antenna length is an important issue. The mode dimension (spot size) grows as $L^{1/2}$, so that scattering angles relevant to the interferometer's performance diminish as $1/L^{1/2}$. General experience with mirrors is that the scattering amplitude becomes larger as a reciprocal power of the scattering angle the closer one approaches to the specular beam (cf. Figure V-12 above). This phenomenon is not fundamental; rather it represents the increasing technical difficulty of controlling mirror figure and slope errors over larger scale lengths on the mirror. The effect of scattering from mirrors could therefore become more serious as the interferometer grows in length. Preliminary studies and a survey of present optical polishing capabilities indicate that there is sufficient margin for the scaling; however further analysis and experimental work is needed. We hope early in the proposed period to specify the mirrors for the initial LIGO receiver and to begin tests of mirror prototypes.

Scattering by the tubing walls and baffles is another area where the scaling to larger lengths must be analyzed further. The relevant angles of scattering and diffraction at the tube walls decrease as $1/L$. The worrisome issue is the phase modulation of the scattered light at the output of the interferometer due to motions by the tube walls and baffles driven by ground noise. This noise source is substantially reduced by keeping the beams as far as possible from the vacuum walls, by proper baffle design, and by the use of spatial filters at the output of the interferometer. Preliminary analysis indicates that there is a safety margin, but a complete analysis, especially to determine an optimum baffle design, must still be carried out. The analysis may require the development of Monte

Carlo computer codes for scattering and diffraction by coherent light. Codes developed by Breault Associates of Tucson, Arizona appear to need only small modification for the LIGO analysis, but they will require a supercomputer to run.

(b) Servo System Analysis for the LIGO

The delay time in some of a receiver's servo systems must increase with increasing arm length. Examples are global beam positioning and pointing servos that have sensors and controllers at opposite ends of the beam tubes, and interferometer fringe locking systems that position controllers on the mirrors. It is important that delay times be kept small enough not to impose serious constraints on servo bandwidths and in turn on servo loop gains. A model for scaling to the LIGO size will be developed during the grant period. This model will include known noise sources that influence beam position, beam pointing, frequency stabilization and fringe lock.

(c) Tests in Available, Other Large Systems.

Much of the scaling can be handled by analysis and modeling, but there may arise a need to test mirrors, scattering, and servo system properties on a larger scale than is now available in the 40-meter system before we commit to final designs for the receivers and facility. As part of the proposed work during the coming year we will determine whether it is useful to set up specific length scaling tests in existing vacuum systems or other facilities such as those at Marshall Space Flight Center at Huntsville or White Sands Proving Ground. Some tests being contemplated involve straightforward scattering measurements of large radius mirrors using the techniques shown in Part V, Figure V-12.

B. Buildup of Experimental Facilities

Introduction

The facilities at MIT and Caltech require expansion and enhancements to accommodate the receivers under development. More specifically, in order to build receivers appropriate in scale and sensitivity for the LIGO we will need increases in electrical power, laser cooling, vacuum system capacity, and computer facilities.

1. Unified Data Acquisition and Analysis

Receiver development will benefit from the use of common hardware and software in the prototype interferometers. Standardized formats for recording and exchanging data will be implemented, and data analysis algorithms tailored for application to LIGO signals will be developed. Interferometers at MIT and Caltech will use similar systems of high-speed analog-to-digital converters, atomic-standard timekeeping and high-density archival storage of data. High-bandwidth cross-continent data links will be evaluated.

2. Unified Development of Control Instrumentation

Commercial modular electronic instrumentation—a combination of the CAMAC and NIM standards—will be used wherever appropriate. A large number of position sensors and transducers (on the order of one hundred) will control suspended masses and optical components. These devices will be standardized. Interferometric fiberoptic position sensors (Figure V-11 and Section VI.A) are being developed. Small computers will be integrated with much of the control circuitry, especially mechanical and low-bandwidth optical servos. The project will also standardize specific, often used circuits such as low noise, high voltage, wide band amplifiers and RF mixer systems.

3. Buildup of the 5-meter Facilities

The vacuum system (tanks, pumps, and associated gauges) for the new 5-meter facility has been installed and tested in recently renovated high bay facilities (Figures VI-8, VI-9). Three cylindrical tanks will hold the interferometer, and a fourth tank will be used to test suspensions and other components. The pumping system is configured to permit separate pumpdown of the interferometer vacuum system and of the auxiliary vacuum system, so that either may be accessed without interrupting the operation of the other. The system is constructed from stainless steel, and its dimensions are shown in Figure VI-8. Each tank consists of a base through which electrical and optical connections will be made and a top to which the beam tubes are attached with quick-release flanges. All of these large flanges are sealed with Viton O-rings. Numerous smaller ports are sealed with copper gaskets. There is rapid clear access to all of the internal components of the interferometer.

The pumping system consists of turbo and ion pumps backed by a mechanical pump. Turbo pumps are used for the initial pumpdown and ion pumps for holding the vacuum. After cleaning with detergent and hot water, the outgassing rate has been measured as 2×10^{-9} torr-liters/sec-cm² of condensable gas and 5×10^{-10} torr-liters/sec-cm² of non-condensable gas.

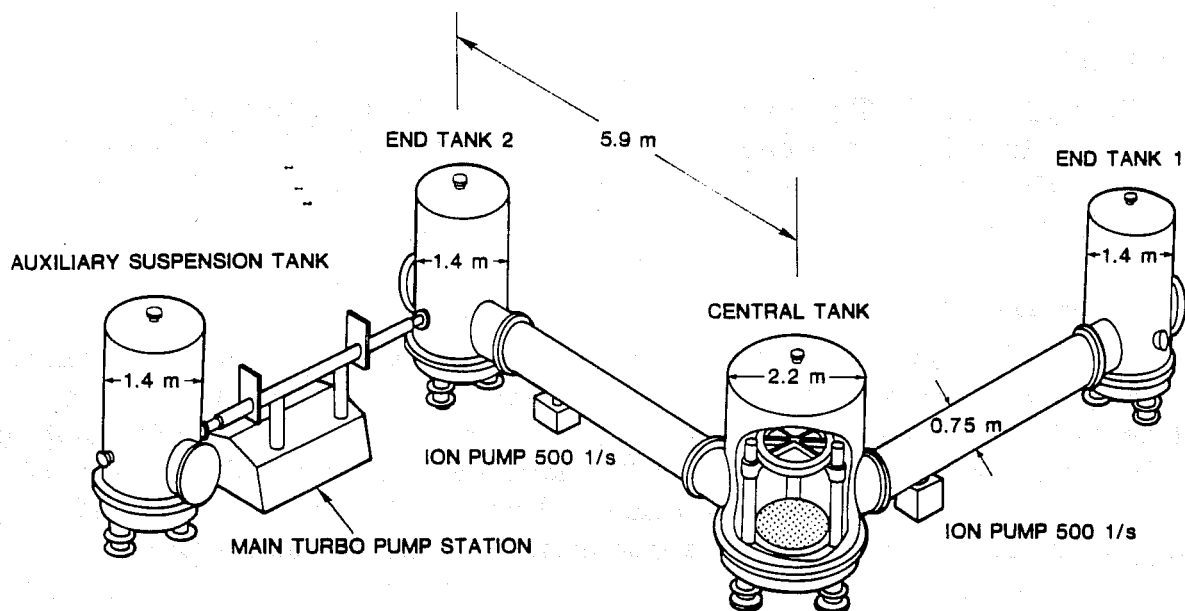

Figure VI-8: Vacuum system for the 5-meter facility

An internal framework to support the test masses is being fabricated. The weight will be supported on three posts in each tank, and the posts will be bridged with vacuum compatible optical tables. The framework will be acoustically isolated from the vacuum enclosure.

4. Enhancements to the 40-meter Prototype

(a) *Vacuum System.* The present 20 cm diameter pipes in the 40-meter vacuum system provide inadequate clearance for the orientation control beams and the main and auxiliary interferometer beams that are required for planned receiver development. We wish to replace them with 60 cm pipes. At the same time, future receiver development will require replacing the 45 cm diameter chambers housing the end masses by chambers 1 to 1.5 meters in diameter. Larger end chambers will also provide a better match to the 1.8 meter central chamber, which is now being fitted out and will be installed early in 1988. The cranes at the end stations will have to be modified or replaced with larger cranes to handle the larger components, and minor modifications to the laboratory building may be required to increase overhead clearances. A new chamber at the central station will hold a mode cleaner several meters long, and smaller chambers will house cavities to filter the output beams.

(b) *Laser Power Capability.* The electrical power and cooling water capacity need to be doubled to accommodate a total of four high power argon ion lasers. Each laser dissipates 50 kW.

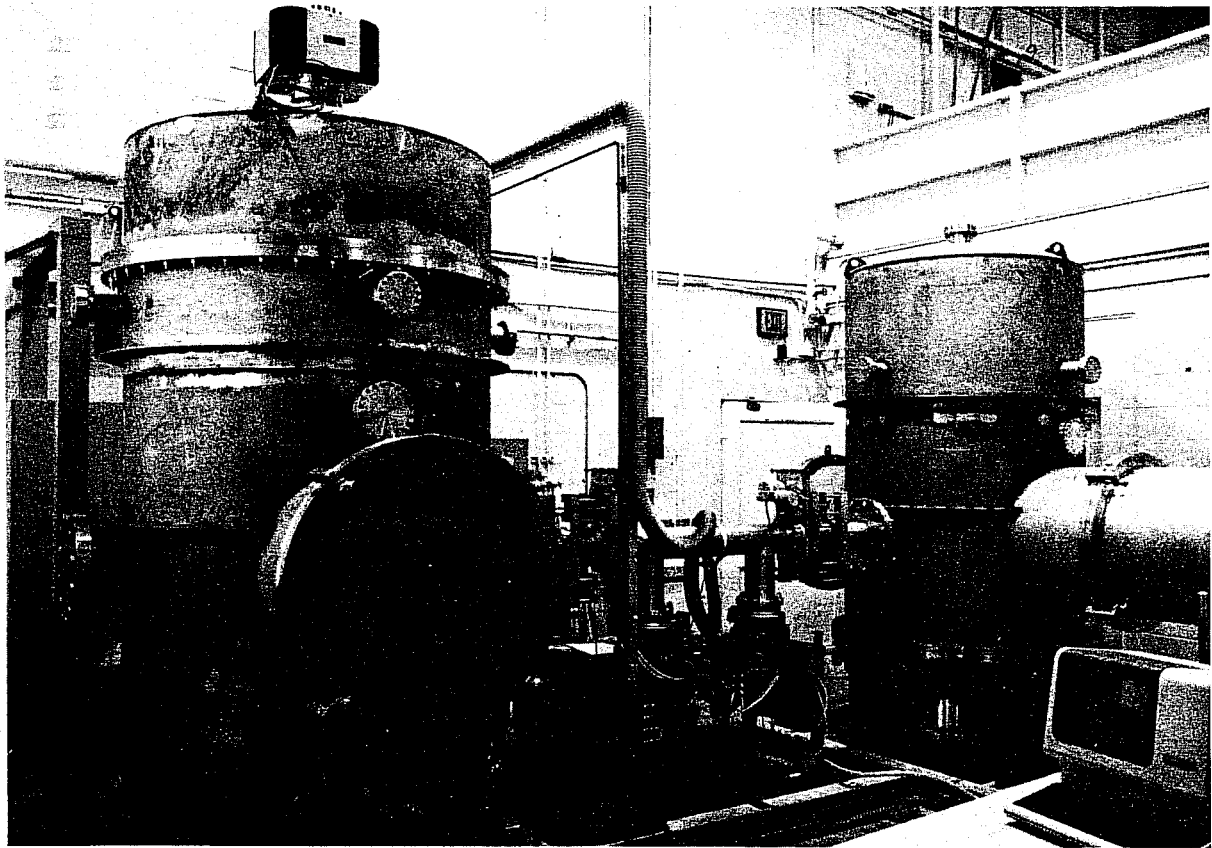
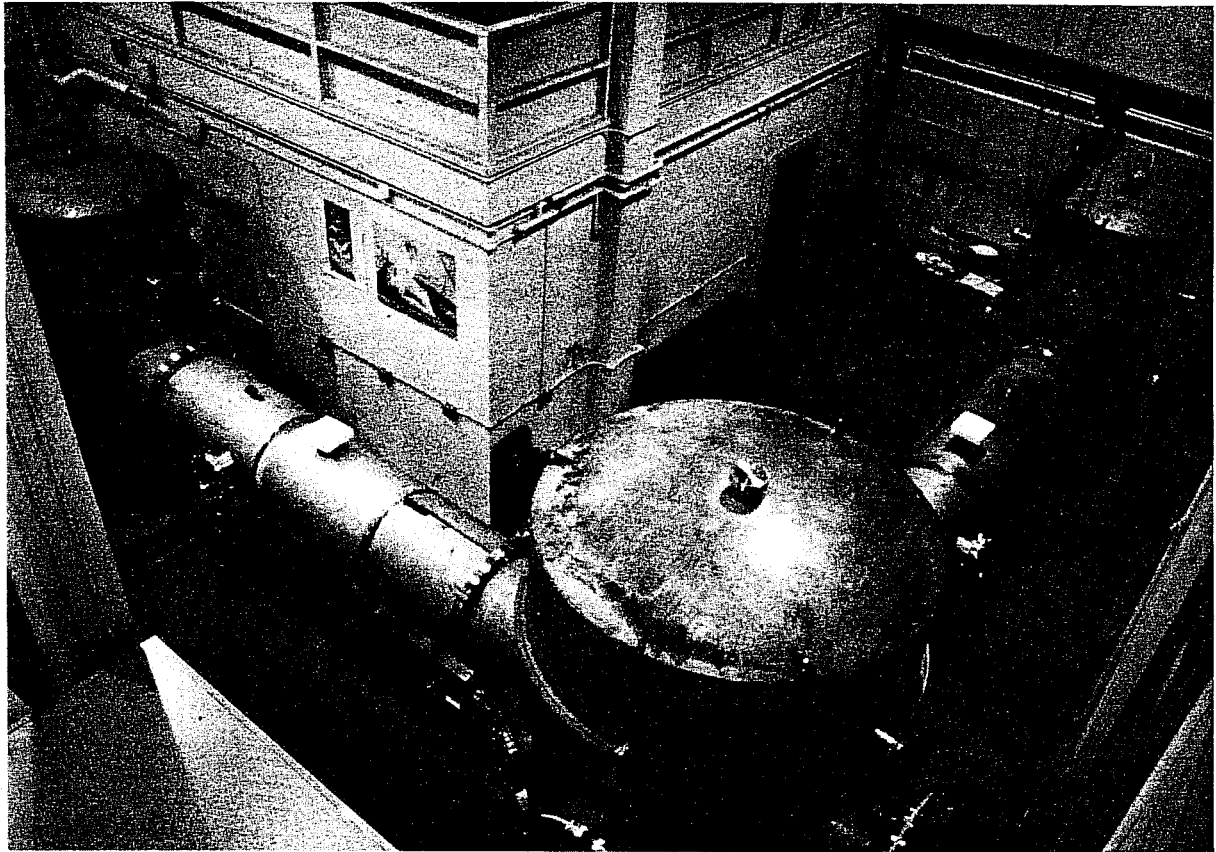

Figure VI-9 Two views of the vacuum system for the 5-meter facility.

C. Conceptual Design for the LIGO

Completion of the conceptual design of the LIGO is scheduled for Fall 1988. It will provide the basis for the Preliminary Engineering Design and Cost Definition. The critical conceptual design issues relating to the LIGO vacuum system, the receiver-facility interfaces, and the capability for multiple-use are being studied by LIGO science working groups in cooperation with the engineering staff.

Vacuum System. The overall concept for the LIGO vacuum system (see Part IV) has been defined by earlier work including the MIT-Stone & Webster-A. D. Little study and efforts by the Caltech Jet Propulsion Laboratory. Detailed vacuum design issues that require further study and definition include:

- 1) Methods to achieve desired material outgassing rates (Section VI.E, below);
- 2) Light scattering and the design of baffles (Section VI.A.3(a) above);
- 3) Environmental requirements:
 - a. Acoustic, seismic and other vibrational noise limits,
 - b. Allowable temperature excursions.

Receiver-Facilities Interfaces. The receiver design is currently not a pacing item in the LIGO schedule. Critical issues related to receiver interfaces with the vacuum system and other facilities, however, must be resolved before starting the Preliminary Design. These include specifications for support structures, optical ports and electrical feedthroughs, and laser power and cooling requirements.

Multi-Use Concept. The first LIGO search for gravity waves will be made with a detector consisting of two interferometric receiver systems, one in each facility. The LIGO, however, is being designed to accommodate multiple receivers. The tube diameter of 48 inches is large enough to handle 4 to 6 beams simultaneously in the Fabry-Perot configuration. In addition, new receivers will be installed and developed at the sites without need for breaking the vacuum of the operating receivers, thus allowing them to continue their search without interruption. This aspect of the conceptual design, which involves the judicious placement of vacuum tanks, gate valves, and support structures for the test masses, will also be completed before the Preliminary Design and Cost Definition.

D. Sites

The two sites for the LIGO will be selected by Spring, 1988 so that sufficient survey work can be completed before the start of the Cost Definition contract. Scientific issues relevant to the selection of a pair of sites within the continental United States were identified and quantified by a LIGO Site Selection Working Group in August, 1987. This study showed that the chosen preliminary site pair, Edwards, California and Columbia, Maine, is acceptable in terms of scientific criteria. Other factors such as site topography and availability are being studied and backup sites are being identified.

E. Vacuum Prototype

A prototype vacuum system is being built to test, demonstrate, and validate critical technology. Tests with this system include:

1. Evaluation of outgassing of the selected tube materials including the effects of surface preparation and cleaning techniques, bakeout procedures, and rates of outgassing as a function of time;
2. Studies of ion pump performance with sub-millisecond time resolution to determine gas-bursting characteristics;
3. Demonstration of key technology areas such as outgassing behavior of welded joints;
4. Measurement of outgassing rates of materials and components intended for use in the receiver systems;
5. Development of instrumentation to monitor gas column density in the 4 kilometer tubes.

This system is designed with bakeable metal/metal seals and valves to permit outgassing measurements of small surface area sections of tube material prepared with different surface cleaning techniques. A full diameter "demonstration" section of the LIGO beam tube using the fabrication, cleaning, and baking methods planned for the LIGO will be subsequently tested. The system will later be used to determine the outgassing properties of receiver components.

Results of tests with the vacuum prototype will be used to specify materials and procedures for use in the engineering design and in the eventual construction of the LIGO vacuum system.

F. Preliminary Engineering Design and Cost Definition

The LIGO receivers, data acquisition and data processing equipment, while quite sophisticated, are relatively low capital cost elements of the LIGO. In this section, we focus attention on the relatively expensive capital parts of the LIGO: vacuum chambers, tubes, valves, pumps and controls; buildings to house the vacuum chambers, tubes, and work areas; power supply and distribution; laser cooling equipment; supporting utilities; environmental monitoring; safety and security; communications and ancillary equipment; and access roads, erosion control, landscaping and related site development work. These items are collectively referred to as "LIGO facilities."

A significant effort has been put forth in defining and demonstrating the feasibility of the LIGO vacuum facilities, buildings and ancillary facilities. Past studies by A. D. Little, Stone & Webster, and the Jet Propulsion Laboratory have shown that the LIGO facilities can be implemented within a reasonable extrapolation of current technology. These feasibility studies, however, have been inadequate to establish definitive cost estimates. The cost uncertainties can be resolved only by going forward with at least a preliminary (partial) systematic engineering design utilizing the full resources of industry. This approach will result in detailed design specifications and will expose and resolve any outstanding or unidentified technical and cost issues.

The objective of the preliminary engineering design activity is to systematically conceive, evaluate and document the implementation aspects of the LIGO facilities to a level of detail sufficient for complete, accurate and reliable cost estimates. The tangible result of this phase of work will be a proposal to the National Science Foundation for the construction of the LIGO. The engineering design process is a continuous one, starting with

these preliminary design activities and leading to construction documentation in the form of working drawings, piece part and process specifications, and detailed construction flow plans and schedules. This full design process will be approximately one third complete at the time of submission of the construction proposal, and will be suspended at that point to permit full review and approval by the NSF. We are recommending this split engineering design approach as the least costly means to provide the NSF with the full information needed to make an informed decision on the construction of the LIGO.

The LIGO facilities engineering design will be carried out by an experienced architectural and engineering firm under contract to Caltech. Starting from the functional specifications and baseline design to be completed during the current conceptual design phase, the contractor will be asked to deliver the following work products:

- a. Progressively prepare schematic design documents, preliminary design or design development documents, drawings, outline specifications and other data required to fix and describe the size and character of the project in the areas of architectural, structural, civil, electrical and mechanical subsystems, materials, processes and such other elements as may be appropriate.
- b. Identify areas of technical or cost risk, and study and report on alternative solutions which promise to reduce cost or risk, and enhance reliability. Develop plans to manage and control significant risk areas that remain in the design.
- c. Prepare a written description of the LIGO facilities in report form including design criteria, potential seismic or corrosion problems, suitability of site soils, and preliminary foundation recommendations.
- d. Identify and prepare detailed drawings and specifications for any long lead procurements and for site development activities that are necessary prior to the start of facilities construction.
- e. Prepare an Implementation Plan for the completion of the engineering design, generation of construction documentation, bidding, construction, construction supervision and quality control activities required for completion of the LIGO facilities. Include such technical, schedule and cost data as necessary to permit an accurate assessment of readiness.
- f. Prepare an estimate of construction costs based upon the preliminary design data, including an analysis of cost uncertainty.

1. Procurement of the Preliminary Engineering Design Contract

Competitive proposals to perform the preliminary engineering design work will be solicited from architectural and engineering firms who can demonstrate a competent performance history on projects with the scope of the LIGO facilities design. To broaden the field of candidate firms, contractors will be encouraged to form teams, combining the technical and management resources of companies specializing in aspects of the LIGO design requirements, provided only that they propose a method of organizing the work between them in a manner that provides a complete solution. One firm or team will be selected based upon criteria yet to be determined. A request for proposal will be prepared and released upon completion of the conceptual design activities and approval of funding by the NSF. After contractor selection, we intend to negotiate a firm fixed price level-of-effort

contract; this contract form is ideally suited to the highly interactive technical development effort required for a state-of-the-art scientific facility.

2. Management of the Preliminary Engineering Design Contract

Contract management is accomplished through the effective use of management tools provided in the formal contract document and informal techniques applied to supplement these control procedures. The primary goal of procedures and techniques implemented in contract management is to assure that adequate control is maintained at all times. Contract change control and contractual direction will be given to the contractor in writing. Requests for changes to contract compliance documents, work requirements, or schedules will be submitted by the contractor after appropriate coordination.

Formal contract status reviews will be held with the contractor monthly. Additional meetings and program reviews may be called as required. Small working level meetings with contractor personnel will be held as frequently as appropriate to quickly resolve specific issues.

Both the formal reviews and working meetings will address technical and programmatic issues as required.

The contractor will prepare a detailed schedule of how the work elements will be performed by the appropriate contractor's operating group. Detailed task schedules must be consistent with the master program schedule. They must present a clear, systematic plan of accomplishment in sufficient detail to provide full visibility of the contractor's performance.

Status reports submitted by the contractor represent a significant means of monitoring contractor manloading and schedule control. To assure that the contractor's system is accurate, it is essential that the contractor have a closed-loop system of internal reporting, covering manloading and schedule progress against planned milestones. The focal point for this information is the contractor's program manager.

On-site contractor surveillance, technical and status interchange and frequent telephone contact will supplement the continuing flow of reports. Action to correct a schedule deviation or a technical problem must be immediate and positive. Once the cause of a problem is determined, a recovery plan is established and implemented.

NSF visibility into all program activities of the contractor will be accommodated. Every effort will be made to satisfy requests for data, meetings or facility visits relating to the contracted efforts.

G. Proposal for Construction

Approximately 16 months after NSF funding of this proposal, we intend to submit a proposal for the construction of the LIGO. We will propose to enter into a contract with the NSF to provide all services and materials required to complete the engineering design, and to develop, construct, test, calibrate, and operate the LIGO facilities including the first receivers. We will offer a plan to accommodate multiple users of the facilities from institutions other than Caltech and MIT. The construction proposal will include such technical, programmatic, cost, and supporting data as are required to permit an in-depth evaluation by the NSF.

THE HISTORY OF THE UNITED STATES

The first part of the book deals with the early history of the United States, from the time of the first European settlers to the end of the American Revolution. It covers the discovery of the New World, the establishment of the first colonies, and the struggle for independence.

The second part of the book deals with the early years of the United States, from the end of the American Revolution to the beginning of the Civil War. It covers the growth of the young nation, the struggle for a stronger federal government, and the expansion of the United States.

The third part of the book deals with the Civil War and Reconstruction, from the beginning of the Civil War to the end of Reconstruction. It covers the causes of the war, the course of the war, and the challenges of rebuilding the South.

The fourth part of the book deals with the late 19th and early 20th centuries, from the end of Reconstruction to the beginning of World War I. It covers the rise of industrialization, the growth of the United States, and the challenges of the Progressive Era.

The fifth part of the book deals with the 20th century, from the beginning of World War I to the present. It covers the challenges of World War I, the Great Depression, World War II, and the challenges of the Cold War and the Vietnam War.

The sixth part of the book deals with the present, from the end of the Vietnam War to the present. It covers the challenges of the Vietnam War, the Watergate scandal, and the challenges of the 1980s and 1990s.

VII. ORGANIZATION AND MANAGEMENT

A. Background

The LIGO is a collaborative effort between the California Institute of Technology and the Massachusetts Institute of Technology. The initial (1984) Caltech-MIT agreement towards the development of the LIGO was implemented as a relatively loose cooperation between two essentially autonomous research and development programs under a three-person Steering Committee (Drever, Thorne (Chair), and Weiss) with the groups pursuing a competing receiver development (Fabry-Perot at Caltech; delay-line at MIT). The common element of the collaboration was the development of joint vacuum facilities for the receivers, under the direction of a project manager reporting to the Steering Committee.

As the LIGO development project evolved, it became increasingly apparent that intellectual and financial resource limitations and quality considerations dictated closer collaboration and a tighter management structure for adequate progress. The 1986 Cambridge Review Panel's recommendations along these lines (Appendix D) were strongly endorsed by NSF management and the Caltech and MIT administrations.

In September 1987, Professor Rochus E. Vogt (former Provost of Caltech and former Chief Scientist of JPL) was appointed Director of the LIGO Project. He has taken steps to establish an engineering group for the LIGO and to fuse, focus and strengthen the efforts of the Caltech and MIT science groups. For example, a prime receiver (Fabry-Perot concept) has been chosen for initial LIGO operations, with a second receiver (delay-line concept) continuing development, at lower level, as an alternate and backup. It is fully realized by both Caltech and MIT that only a unified project under a firm management (respecting the uniqueness and creativity of each science group) can do justice to a successful implementation of this very complex scientific and engineering project, within schedule and budget.

B. Organization

The present organization of the LIGO Team is shown in Figure VII-1. The Director has overall responsibility for the organization, integration and coordination of the LIGO effort. He will be responsible for the management, control and accounting of LIGO resources, and for communications and reporting to the NSF. The Director will solicit advice on scientific and engineering strategies from a Science Steering Group composed of the Co-investigators, and a Design Review Board consisting of engineering and technical management experts from outside the LIGO Project. These advisory groups function in addition to the traditional oversight mechanisms applied by NSF.

The science groups at Caltech and MIT are headed by Professors Drever and Weiss, respectively. They will focus upon joint efforts under a unified development program, but taking full advantage of the strength to be gained from the diversity unique to these two strong science and engineering institutions. The two groups will concentrate on aspects of receiver research and development, and will provide substantial scientific support to the planning and engineering of the LIGO facilities. A modest but significant strengthening of both groups, necessary for a task of the magnitude of the LIGO, is

planned over the next few years. Both the Caltech and MIT administrations have authorized the resources for the addition of tenure-track faculty to the LIGO Project, and recruitment efforts are underway. Additional postdoctoral staff and some technical support personnel are also planned. Professor Thorne and selected members of his research group will provide theoretical and analytical support to the project, as needed.

LASER INTERFEROMETER GRAVITATIONAL WAVE PROJECT (LIGO)

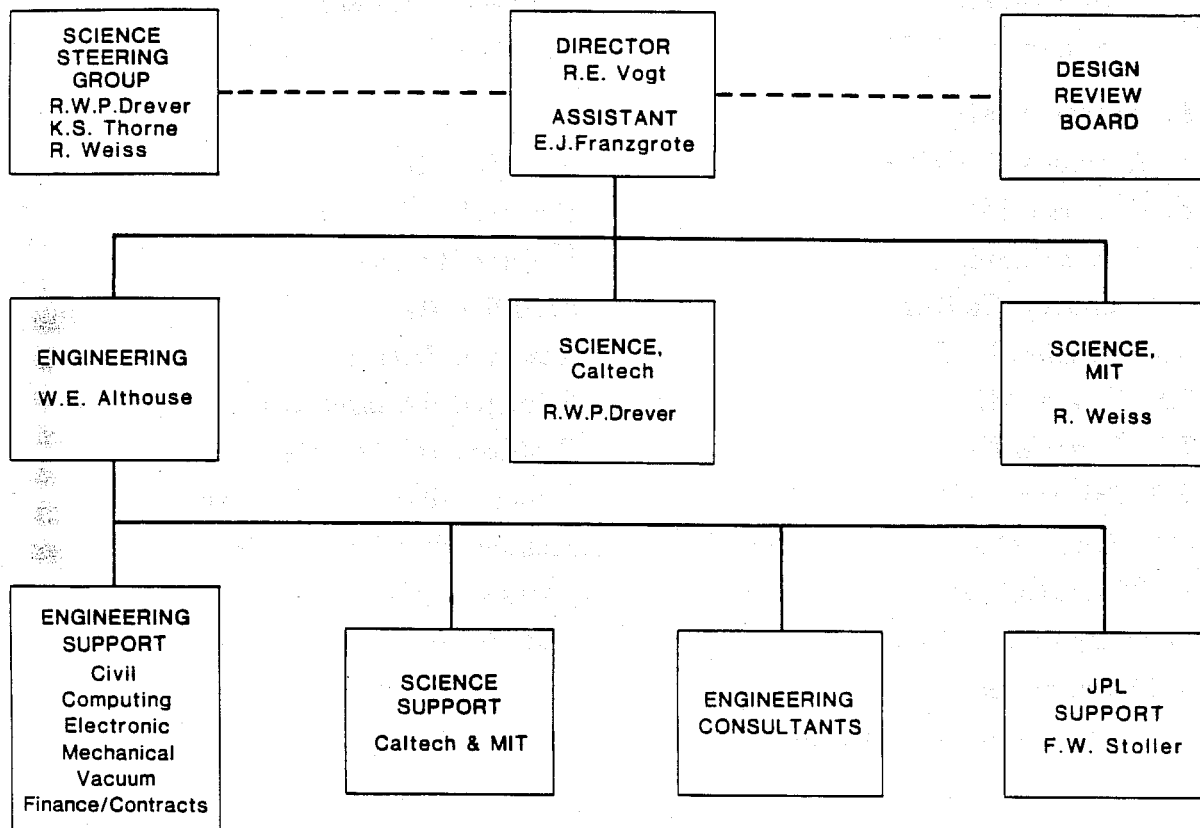

Figure VII-1: LIGO Organization Chart.

The engineering group, in close cooperation with the science groups, will be responsible for the planning and engineering of the LIGO facilities and supporting equipment and services, including management and supervision of the preliminary engineering design contractor, and will provide engineering services for the development of receivers to be installed in the LIGO. The Chief Engineer, William E. Althouse, is in place and has begun to assemble a core group of engineering and support personnel to carry out these tasks. Full advantage is being taken of ready access to the diverse engineering strength of Caltech's JPL for supplementary specialist support as needed.

C. Personnel

Present plans anticipate that the scientific, engineering and support personnel will be composed of the following staff:

Professorial Faculty

R.E. Vogt, Caltech (P.I., P.D.)

R.W.P. Drever, Caltech (Co-I.)

K.S. Thorne, Caltech (Co-I.)*

R. Weiss, MIT (Co-I.)

to be appointed, Caltech

to be appointed, MIT

Director, Professor of Physics

Professor of Physics

Professor of Theoretical Physics

Professor of Physics

Assistant Professor of Physics

Assistant Professor of Physics

Scientific Staff

A. Abramovici, Caltech

E.M. Burka, MIT

A. Cadez, Caltech

H.Y. Gursel, Caltech

A.D. Jeffries, MIT

P.S. Linsay, MIT

J.C. Livas, MIT

P.R. Saulson, MIT

R.E. Spero, Caltech

M. Tinto, Caltech*

to be appointed, Caltech

to be appointed, MIT

to be appointed (2), Caltech

Staff Scientist

Research Scientist

Visiting Associate

Staff Scientist

Research Scientist

Principal Research Scientist

Postdoctoral Associate

Principal Research Scientist

Member, Professional Staff

Research Fellow

Staff Scientist

Postdoctoral Associate

Research Fellow

* Salary supported under Thorne's NSF grant.

Professional Staff

W.E. Althouse, Caltech
R.L. Benford, MIT
E.J. Franzgrote, Caltech
J.H. Harman, Caltech
B.C. Moore, Caltech
to be appointed, MIT
to be appointed, Caltech
to be appointed, Caltech
to be appointed, Caltech
to be appointed, Caltech

Technical Support

B.A. Tinker, Caltech
S.I. Vass, Caltech
to be appointed, MIT
to be appointed, Caltech
to be appointed, Caltech

Secretarial Support

C. Akutagawa, Caltech
B. Behnke, Caltech
B. Busch, MIT
to be appointed, Caltech

Chief Engineer
Research Engineer
Assistant to the Director
Electronics Engineer
Vacuum Engineer
Research Engineer
Civil Engineer
Mechanical Engineer
Software Engineer
Finance/Contracts

Electronics Technician
Vacuum Technician
Electronics Technician
Electronics Technician
Vacuum Technician

Caltech Science Group
Director's Office
MIT Science Group
Engineering Group

VIII. BUDGET

This is a three year proposal for continuation of activities currently supported by the National Science Foundation under two grants: PHY-8504136 to the California Institute of Technology (Drever, PI) and PHY-8504836 to the Massachusetts Institute of Technology (Weiss, PI). The proposed activities, combining the resources of both institutions under the management of the Director, will lead to a proposal for the construction of the LIGO, which we expect to submit in Fall 1989. When funded, the anticipated construction contract will replace the funding requested for the third year of the current proposal.

The Director will control the LIGO effort through technical and administrative direction, implemented by adjusting the allocation of manpower and financial resources as required to meet the needs and commitments of the LIGO Project. A baseline budget plan is given in the tables below, organized into three operating cost centers. A summary of the total budget request is shown in Table I. Table II gives a detailed breakdown for LIGO Science, Management and Engineering; this cost center includes the Director's Office, analytical science support, the engineering group, and supporting services from the Caltech's JPL, industrial and private consultants and the Preliminary Engineering Design contractor. Tables III and IV give detailed breakdowns for the Caltech and MIT science groups, respectively, including receiver research and science support for LIGO planning.

The Tables are followed by a presentation of budget details in the NSF standard format. For administrative and management reasons, the support for the MIT research group is shown as a subcontract to Caltech on line G5 of these forms. *The reader is cautioned, therefore, that an accurate impression of the level of effort proposed is to be found in Tables II, III, and IV; sections A and B of the standard NSF format, while contractually correct, may be misleading.*

Explanatory notes and supporting data follow the NSF budget forms. The following general notes apply to all tables and to the NSF format budget presentation:

Inflation. Entries are based upon actual, calculated or estimated FY88 data, as appropriate, and adjusted for inflation into the grant period of performance at a rate of 6% per year, except where otherwise noted.

Salaries. The staff for the LIGO Project is listed in Section VII. Actual FY88 salaries are used for existing personnel and estimates are used for salaries of personnel to be appointed. Salaries for Drs. Thorne and Tinto are paid fully by Caltech and Thorne's separate NSF grant, and are not included here.

Consultants. This item is used generically to identify and segregate anticipated costs associated with Design Review Board appointees, including travel cost reimbursement, and private or industrial consultants employed to resolve technical problems which arise outside of the scope of the preliminary engineering design subcontract. Design Review Board members will be selected from among technical experts in relevant disciplines and may be employees of Government or industry, or may be private consultants. Formal arrangements with these individuals or their employers will be made on a case-by-case basis, in accordance with all applicable NSF and FPR policies and regulations.

MIT subcontract. Level of effort, rates and amounts shown are budgetary estimates based upon informal discussions with MIT. Details are given in the budget explanatory notes. MIT will submit a proposal to Caltech supporting and justifying all proposed costs, and the resulting negotiated contract will reflect such supporting data.

Preliminary engineering design subcontract. The scope and intent of this proposed subcontract is described in Section VI. A budgetary estimate of \$3 million is included for this effort. This amount is based upon preliminary discussions with potential contractors and other users of A&E contractor services, as well as our own experience. Actual costs of the preliminary engineering design contract will depend on the selected contractor's labor and burden rates, proposed methods of approaching the design, and risk/cost trade-offs in the breadth, depth and quality of the work products. As explained in section VI-F above, the contractor will be competitively selected, and the contract will be a negotiated fixed price level of effort type to allow us to exercise risk/cost trade-offs as the work proceeds while giving us full control over contract costs.

Residual Funds Statement

We anticipate no residual funds in either the Caltech grant or the MIT grant at the end of the current funding period.

IX. REFERENCES

- III-1 J. Weber, *Physical Review D* **22** (1969), 1302.
- III-2 R. Weiss, *Quart. Progr. Rep. Res. Lab. Elect. MIT* **105** (1972), 54.
- III-3 G. E. Moss, L. R. Miller, and R. L. Forward, *Applied Optics* **10** (1971), 2495.
- III-4 R. W. P. Drever, G. M. Ford, J. Hough, I. M. Kerr, A. J. Munley, J. R. Pugh, N. A. Robertson, and H. Ward, *Proceedings of the Ninth International Conference on General Relativity and Gravitation* (Jena 1980), ed. E. Schmutzer (VEB Deutscher Verlag der Wissenschaften, Berlin, 1983), 265.
- III-5 P. Linsay, P. Saulsen, R. Weiss, "A Study of a Long Baseline Gravitational Wave Antenna System", Report to the National Science Foundation (1983).
- III-6 "Physics Through the 1990's—Gravitation, Cosmology, and Cosmic Ray Physics", National Research Council, National Academy Press, Washington, D. C., 1986.
- V-1 R. W. P. Drever, G. M. Ford, J. Hough, I. M. Kerr, A. J. Munley, J. R. Pugh, N. A. Robertson, and H. Ward, *Proceedings of the Ninth International Conference on General Relativity and Gravitation* (Jena 1980), ed. E. Schmutzer (VEB Deutscher Verlag der Wissenschaften, Berlin, 1983), 265.
- V-2 R. W. P. Drever, J. Hough, A. J. Munley, S.-A. Lee, R. Spero, S. E. Whitcomb, H. Ward, G. M. Ford, M. Hereld, N. A. Robertson, I. Kerr, J. Pugh, G. P. Newton, B. Meers, E. D. Brooks, and Y. Gursel, *Laser Spectroscopy V*, ed. A. R. W. McKellar, T. Oka, and B. P. Stoicheff (Springer, New York 1981) 33.
- V-3 R. W. P. Drever, J. L. Hall, F. V. Kowalski, J. R. Hough, G. M. Ford, A. J. Munley, H. Ward, *Applied Physics B* **31** (1983), 97.
- V-4 R. W. P. Drever, S. Hoggan, J. Hough, B. J. Meers, A. J. Munley, G. P. Newton, H. Ward, D. Z. Anderson, Y. Gursel, M. Hereld, R. Spero, and S. E. Whitcomb, *Proceedings of the Third Marcel Grossmann Conference on General Relativity 1982*, ed. Hu Ning (Science Press and North-Holland Publishing Co., 1983) 739.
- V-5 Robert Spero, D. Z. Anderson, R. W. P. Drever, Y. Gursel, G. Gutt, Mark Hereld, J. Kaufman, S. E. Whitcomb, *Tenth International Conference on General Relativity and Gravitation, Padua* ed. B. Bertotti, F. deFelice, A. Pascolini (Consiglio Nazionale Delle Ricerche—Roma, 1983) 930.
- V-6 R. Spero, *Proceedings of the Fourth Marcel Grossmann Conference on General Relativity 1986*, ed. R. Ruffini (Elsevier Science Publishers B.V., 1986) 615.
- V-7 Stanley E. Whitcomb, Caltech Internal Report, "Shot Noise in the Caltech Gravitational Wave Detector—the Mid-1984 Configuration", (unpublished).
- V-8 R. Weiss, *Quart. Progr. Res. Lab. Elect. MIT* **105** (1972), 54.
- V-9 J. Livas, R. Benford, D. Dewey, A. Jeffries, P. Linsay, P. Saulson, D. Shoemaker, R. Weiss, *Proceedings of the Fourth Marcel Grossman Meeting on General Relativity* R. Ruffini ed., (1985), 591.
- V-10 T. J. Kane, R. L. Byer, *Optics Letters* **10** (1985), 65.
- V-11 W. S. Martin, J. P. Chernoch, U. S. Patent 3633126 (1972) "Multiple internal reflection face pumped laser".
- V-12 J. M. Eggleston, T. J. Kane, K. Kuhn, J. Unternahrer, R. L. Byer, *IEEE Journal Quant. Elect* **QE20** (1984), 289.

- V-13 W. J. Kozlovsky, C. D. Nabors, R. L. Byer, "Efficient second harmonic generation of a diode-laser pumped cw Nd:YAG laser using monolithic MgO:LiNbO₃ external resonant cavities", (preprint) (1987).
- V-14 J. Livas, "Upper limits for gravitational radiation from some astrophysical sources", MIT Ph.D Thesis (1987).
- V-15 D. Dewey, "A search for astronomical gravitational radiation with an interferometric broadband antenna", MIT Ph.D Thesis (1986).
- V-16 Sheryl Smith, *Physical Review D* **36** (1987), 2901.
- V-17 D. Dewey, *Physical Review D* **36** (1987), 1577.
- VI-1 J. L. Hall and T. W. Hänsch, *Optics Letters* **9** (1984), 502.
- VI-2 G. A. Kerr, N. A. Robertson, J. Hough, C. N. Man, *Applied Physics* **B37** (1985), 11.
- VI-3 T. J. Kane, R. L. Byer, *Optics Letters* **10** (1985), 65.
- VI-4 T. J. Kane, W. J. Kozlovsky, R. L. Byer, *Optics Letters* **11** (1986), 216.
- VI-5 R. W. P. Drever, J. Hough, A. J. Munley, S.-A. Lee, R. Spero, S. E. Whitcomb, J. Pugh, G. Newton, B. Meers, E. Brooks III, Y. Gursel, *Quantum Optics, Experimental Gravity, and Measurement Theory* ed. P. Meystere and M. O. Scully, (Plenum Publishing, 1983), 503.
- VI-6 R. W. P. Drever, *Gravitational Radiation*, NATO Advanced Physics Institute, Les Houches, ed. N. Deruelle and T. Piran, (North Holland Publishing, 1983), 321.
- VI-7 C. M. Caves *Physical Review D* **23** (1981), 1693; M. Xiao, L.-A. Wu, and H. J. Kimble, *Physical Review Letters* (1987).
- VI-8 A. Čadež, A. Abramovici, "Measuring high mechanical quality factors of bodies made of bare insulating materials" *Journal of Physics E* (in press) (1988).
- VI-9 V. B. Braginsky, V. P. Mitrofanov, V. I. Panov, *Systems with Small Dissipation*, ed. Cynthia Eller and Kip S. Thorne, University of Chicago Press (1985).
- VI-10 H. Bennett, private communication.
- VI-11 D. Z. Anderson, *Applied Optics* **23** (1984), 1238.

VITAE

Rochus E. Vogt

Born: December 21, 1929, Germany (FRG)
U.S. Citizen

Present Position: R. Stanton Avery Distinguished Service Professor and
Professor of Physics
Director, Caltech/MIT Laser Interferometer Gravitational-
Wave Observatory (LIGO) Project

Education: 1952-cand. phys. Technische Hochschule Karlsruhe, FRG
Universität Heidelberg, FRG
1957-S.M. University of Chicago
1961-Ph.D. University of Chicago

Positions: 1953-1961 Research Assistant, Enrico Fermi Institute for
Nuclear Studies, University of Chicago
1961-1962 Research Associate, Enrico Fermi Institute for
Nuclear Studies, University of Chicago
1962-1965 Assistant Professor of Physics, Caltech
1965-1970 Associate Professor of Physics, Caltech
1970-present Professor of Physics, Caltech
1975-1977 Chairman of the Faculty, Caltech
1977-1978 Chief Scientist, Jet Propulsion Laboratory (JPL),
Caltech
1978-1983 Chairman, Division of Physics, Mathematics and
Astronomy, Caltech
1980-1981 Acting Director, Owens Valley Radio Observatory,
Caltech
1982-present R. Stanton Avery Distinguished Service Professor,
Caltech
1983-1987 Vice President and Provost, Caltech
1987- Director, Caltech/MIT Laser Interferometer
Gravitational-Wave Observatory (LIGO) Project

Research:

Research on astrophysical aspects of cosmic radiation and in gamma-ray astronomy.

Gravitational Wave Astronomy.

Co-investigator (1962-1969) and Principal Investigator (1969-1983) on NASA grant supporting space research at Caltech. Principal Investigator on NASA's Voyagers 1 and 2 missions (1972-1984). Co-investigator on cosmic ray experiments on NASA's OGO-6, IMP 7 and 8, HEAO-3, ISEE-3 missions.

Other
Activities: 1963-present Various consultantships with government and industry
1971-1973 Panel on Alternate Approaches to Graduate Education
(Council of Graduate Schools in the US)
1973-1976 Physical Sciences Committee (NASA)
1984-present Member of the Board of Directors, International Rectifier
Corporation
1985-1987 Member of the Board of Directors, California Association for
Research in Astronomy

Professional
Societies: American Physical Society (Fellow)
American Association of Physics Teachers
American Association for the Advancement of Science

Honors: Member, Studienstiftung des deutschen Volkes (1950-1953)
Fulbright Fellow (1953-1954)
Professional Achievement Award (1981), University of Chicago Alumni
Association
NASA Exceptional Scientific Achievement Medal (1981)
R. Stanton Avery Distinguished Service Professor, Caltech (1982)

Ronald William Prest Drever

Born: October 26, 1931, Scotland
British Citizen

Present Position: Professor of Physics
California Institute of Technology (Caltech)

Education: 1953-B.S. Glasgow University
1958-Ph.D. Glasgow University

Positions: 1956-1960 Research Fellow, Glasgow University
1960-1967 Lecturer, Glasgow University
1960-1961 Research Fellow, Harvard University, (LOA, Glasgow University)
1967-1973 Senior Lecturer, Glasgow University
1973-1975 Reader, Glasgow University
1975-1979 Titular Professor, Glasgow University
10/77-1/78 Visiting Associate, Caltech
1979-1984 Professor of Physics, Part-time, Caltech
1979-1984 Professor of Physics, Part-time, Glasgow University
1984-present Professor of Physics, Caltech

Research:

Ph.D. and post-doctoral work in experimental nuclear physics and low energy beta spectroscopy, including experiments relevant to neutrino mass, and on spectrum and half-life of rhenium 187 setting limits to change of fine structure constant with geological time. Experiments on anisotropy of inertial mass by nuclear free precession in the earth's magnetic field. Work on Mossbauer effect, at Harvard; on studies of cosmic rays by atmospheric Cerenkov radiation, at Harwell; on pulse radio astronomy and other astronomical experiments.

Worked on gravitational radiation experiments since 1972. Developed wide-band gravity-wave bar detectors and made first extensive searches for pulses; stochastic background radiation with them. Developed laser interferometer gravity wave detection techniques using optical cavities, first at the University of Glasgow, subsequently at Caltech. Head of the Experimental Gravity Group at Caltech, and Co-investigator in proposed large scale Caltech/MIT LIGO project.

Other Activities: 1968-1972 Consultant and Vacation Assistant, Atomic Energy Research Establishment, Harwell (U.K. Atomic Energy Authority)
1972-1974 Member of the Astronomy Policy and Grants Committee, (U.K. Science Research Council)
1972-1976 Council Member of the Royal Astronomical Society
1973-1976 Vice President of the Royal Astronomical Society
1974 Consultant, National Science Foundation (U.S.A.)
1974-1976 Royal Astronomical Society Assessor to the Astronomy I Committee
1979 Morris Loeb Lectureship in Physics, Harvard University
1985 Ernest Guptill Memorial Lecturer, Dalhousie University, Canada

Professional Societies: Fellow of the Royal Society of Edinburgh
Member of the International Society of General Relativity on Gravitation

Kip S. Thorne

Born: June 1, 1940, Logan, Utah, USA
U.S. Citizen

Present Positions: The William R. Kenan, Jr., Professor, and Professor of Theoretical Physics, Caltech
Adjunct Professor Physics, University of Utah
Andrew D. White Professor at Large, Cornell University

Education: 1962 B.S. California Institute of Technology
1963 A.M. Princeton University
1965 Ph.D. Princeton University

Positions: 1965-1966 Postdoctoral Fellow in Physics, Princeton
1966-1967 Research Fellow in Physics, Caltech
1967-1970 Associate Professor of Theoretical Physics, Caltech
1970-present Professor of Theoretical Physics, Caltech
1971-present Adjunct Professor of Physics, University of Utah
1981-present The William R. Kenan, Jr., Professor, Caltech
1986-present Andrew D. White Professor at Large, Cornell

Research: Theoretical physics, gravitation physics, astrophysics.

Other Activities: International Committee on General Relativity and Gravitation, 1971-1980
Committee on US-USSR Cooperation in Physics, 1978-1979
Advisory Board, Institute for Theoretical Physics, Santa Barbara, 1978-1980
Space Science Board, 1980-1983

Honors: Fulbright Lecturer in France, 1966
Alfred P. Sloan Foundation Research Fellow in Physics, 1966-1968
John Simon Guggenheim Fellow, 1967-1968
AIP-U.S. Steel Foundation Science Writing Award in Physics and Astronomy, 1969
Fellow, American Academy of Arts and Sciences, 1972-present
Member, National Academy of Sciences, 1973-present
Honorary Doctor of Science, Illinois College, 1979
Doctoris Honoris Causa, Moscow University, 1981

Professional Societies: American Astronomical Society
International Astronomical Union
American Physical Society, Fellow
American Association for the Advancement of Science, Fellow

Rainer Weiss

Born: September 29, 1932, Berlin, Germany
U.S. Citizen

Present Position: Professor of Physics, Massachusetts Institute of Technology

Education: 1955-B.S. - Massachusetts Institute of Technology
1962-Ph.D. Massachusetts Institute of Technology

Positions: 1960-1961 Instructor of Physics, Tufts University
1961-1962 Assistant Professor of Physics, Tufts University
1962-1964 Research Associate in Physics, Princeton University
1964-1967 Assistant Professor of Physics, M.I.T.
1967-1973 Associate Professor of Physics, M.I.T.
1973-present Professor of Physics, M.I.T.

Research: Experimental Atomic Physics, Atomic Clocks, Laser Physics, Experimental Gravitation, Millimeter and Sub-millimeter Astronomy, Cosmic Background Measurements, Major Projects: Atomic Clock development, Balloon program to measure Cosmic Background Radiation, Science Working Group Chairman, COBE satellite program, Laser Interferometer Gravitational-Wave Observatory (LIGO)

Professional Societies: American Association for the Advancement of Science
American Physical Society

Other Activities: NASA Physical Science Committee, 1970-1974
National Academy Summer Study on Outer Planet Exploration, 1972
NASA Management Operations Working Group for Shuttle Astronomy, 1973-1976
NASA Management Operations Working Group for Airborne Astronomy, 1973-1986
Chairman, NASA Panel on Experimental Relativity and Gravitation, 1974-1976
NCAR Scientific Ballooning Advisory Panel, 1971-1978
Chairman, NCAR Scientific Ballooning Advisory Panel, 1974-1978
Members' Representative to NCAR from M.I.T., 1974-1982
Chairman, NSF Subcommittee on Gravitational Physics, 1978
NASA SSSC Committee, 1979-1982
NASA Infrared Detector Panel, 1978
NASA Space and Earth Science Advisory Committee, 1982
National Academy Space Science Board, 1983-1986
Panel Chairman on Fundamental Physics and Chemistry, National Academy Summer Study, Major Directions for Space Research 1995-2015, 1984-86
Panel for the Joint Institute of Laboratory Astrophysics, Board on Assessment of NBS Programs, National Academy of Sciences, 1985-

Alex Abramovici

Born: May 14th, 1945. U.S.S.R.
Israeli Citizen

Present Position: Staff Scientist, Gravitational Physics,
California Institute of Technology

Education: 1968-M.Sc. University of Timisoara, Romania
1985-Ph.D. Weizmann Institute of Science, Israel

Positions: 1985-1986 Postdoc, Weizmann Institute of Science
1986-1987 Scientist, Weizmann Institute of Science

Research:

Laser physics, laser stabilization, single mode operation of lasers, very low noise He-Ne lasers, laser heterodyne measurements, high efficiency seismic isolation systems, noise analysis, measurement of very small displacements using laser interferometers, laser gravitational wave detectors.

Honors: The Giora Yashinski Memorial Prize (1984)

William E. Althouse

Born: December 2, 1942, Los Angeles, California
U.S. Citizen

Present Position: Member of the Professional Staff, Caltech
Chief Engineer, Caltech/MIT Laser Interferometer
Gravitational-Wave Observatory (LIGO) Project

Education: 1968-B.S.E.E. California State Polytechnic University

Positions: 1963-1964 Electronics Technician, Caltech
1964-1965 Junior Engineer, Caltech
1965-1969 Associate Engineer, Caltech
1969-1972 Electronics Engineer, Caltech
1972-1979 Senior Engineer, Caltech
1979-1981 Technical Manager, Caltech
1981- Member of the Professional Staff, Caltech
1981-1987 Chief Engineer, Space Radiation Laboratory, Caltech
1987- Chief Engineer, Caltech/MIT Laser Interferometer
Gravitational-Wave Observatory (LIGO) Project

Research:

Developed, managed, supervised and/or participated in gamma-ray astronomy and high energy charged particle experiments: Team Leader, balloon-borne gamma-ray imaging observations of SN1987a; engineering supervisor, Heavy Ion Counter experiment, Galileo Project; engineering supervisor, Gamma-Ray Imaging Payload Project; Experiment Manager, Comprehensive Particle Analysis System, International Solar Polar Mission; Experiment Manager, Heavy Isotope Spectrometer Telescope experiment, International Sun-Earth Explorer Project; Deputy Experiment Manager, Cosmic Ray Subsystem, Voyager Project; Project Manager, Electron-Isotope Spectrometer, Interplanetary Monitoring Platforms 7 and 8; Project Engineer, Galactic Cosmic Ray Experiment, Orbiting Geophysical Observatory Project.

Other

Activities: Assistant Chairman, Nuclear Science Symposium, 1979-1985

Professional Societies: Institute of Electrical and Electronics Engineers
IEEE Nuclear Sciences and Plasma Society
IEEE Aerospace and Electronic Systems Society
IEEE Computer Society
IEEE Instrumentation and Measurement Society
IEEE Lasers and Electro-Optics Society

Richard L. Benford

Born: February 25, 1942
British Citizen

Present Position: Sponsored Research Technical Staff,
Massachusetts Institute of Technology

Education: 1962 Ordinary National Certificate Mechanical Engineering
Acton Technical College, Acton, London, England
1978 Bachelor of Engineering Technology Electrical Engineering,
Northeastern University

Positions: 1959-1963 Napier Aero Engines, Acton, London, England
1963-1965 Cryonetics Corporation, Burlington, MA., U.S.A.
1966-1967 Spemby Technical Products, Ltd., Sittingbourne, Kent, England
1967-1969 University of Western Ontario, London, Ontario, Canada
1969-present Massachusetts Institute of Technology, Cambridge MA, U.S.A.

Research:

Gravitational wave detection: Resident Engineer—worked with project leaders on Gravity wave antenna prototype and vacuum system design, liason with contractor and suppliers of raw materials. Measurement of cosmic background radiation: mechanical design and field support of balloon borne Infrared experiment. Technical aide to physics department head: maintained undergraduate physics laboratory. Lab Technician: research and development of liquid nitrogen level controllers and cryosurgical instruments for eye surgery. Testing, instrumenting and evaluating test data on miniaturised liquid helium and nitrogen compressors. Gas turbine aircraft engine fitting, inspection and certification, diesel electric engine repair and assembly.

E. Michael Burka

Born: October 17, 1957, Washington, D.C.
U.S. Citizen

Present

Position: Research Scientist, Massachusetts Institute of Technology

Education: 1979—B.A. University of Pennsylvania
1981—M.A. Johns Hopkins University
1985—Ph.D. Johns Hopkins University

Positions: 1979—1982 Teaching Assistant, Johns Hopkins University
1980—1985 Research Assistant, Johns Hopkins University
1985—1987 Postdoctoral Research Associate, MIT
1987—present Research Scientist, MIT

Research: High Energy Physics
Gravitational Wave Astrophysics

Professional Societies: American Physical Society
American Association for the Advancement of Science

Honors: Pi Mu Epsilon, elected 1978

Andrej Marjan Čadež

Born: September 12, 1942, Yugoslavia
Yugoslav Citizenship

Present Position: Visiting Associate in Physics
California Institute of Technology (Caltech)

Education: -B.S. University Edvard Kardelj in Ljubljana
1971-Ph.D. University of North Carolina, Chappel Hill

Positions: 1974 Research Fellow, Meudon, France
1976 Research Fellow, Oxford University (U.K.)
9/86-8/87 Visiting Associate in Physics, Caltech
1983-present Director, Astronomical Observatory in Ljubljana
1982-present Professor of Physics, University Edvard Kardelj in Ljubljana

Research:

- Development of a gravity gradiometer.
- Theoretical and experimental aspects of gravitational wave detection.
- Development of mechanical oscillators with long relaxation times.
- Experimental and theoretical studies in test masses used for detection of gravitational waves by laser interferometers.
- Development of techniques for stabilizing and precisely controlling the position of suspended test masses.

Honors: Fulbright award for graduate study (1967)
Scholarship of Slovenian Science Foundation (1974)
Fellowship for 6 months research at Oxford University (U.K.)(1976)
Award of Boris Kidric Foundation (1976)
Fulbright Scholar at Caltech (9/86-8/87)

Ernest J. Franzgrote

Born: December 25, 1930, Peoria, Illinois

Present Position: Assistant to the Director, Caltech/MIT Laser Interferometer Gravitational-Wave Observatory (LIGO) Project

Education: 1957-MS California Institute of Technology
1959-1961 University of Munich

Positions: 1957-1959 Research Scientist and Engineer (JPL), Caltech
1961-1971 Co-Investigator, Surveyor Project (JPL), Caltech
1971-1974 Senior Research Scientist and Engineer (JPL), Caltech
1974-1981 Experiment Representative, Voyager Project (JPL), Caltech
1981-1986 Project Manager Representative (JPL), Caltech
1986-1987 Senior Executive Assistant to the Provost, Caltech
1987- Assistant to the Director, Caltech/MIT Laser Interferometer Gravitational-Wave Observatory (LIGO) Project

Research:

Research on chemical separation processes.

Development of methods for analysis of the Martian atmosphere.

Geo- and selenochemical studies.

First analysis of the lunar surface as co-investigator on NASA's Surveyor 5-7 missions.

Fields and particles studies on the outer planets.

Analysis of flights of remotely-piloted vehicles, human-powered and solar-powered airplanes, and of the Trochilidae.

Honors:

Letters of commendation from managers of the Remotely Piloted Vehicle Project, 1982 and 1985.

NASA's Exceptional Service Medal, Voyager Project, 1981.

Participant in three projects that have received the Collier Trophy in aviation and space flight.

Shared in the Kremer Prize for the first human-powered flight across the English Channel, 1980.

Halis Yekta Gürsel

Born: May 15, 1953, The city of Samsun, Turkey
Citizen of The Republic of Turkey
Permanent resident of the U.S., Visa # A24937520

Present Position: Staff Scientist
California Institute of Technology (Caltech)

Education: 1975-B.S. Middle East Technical University, Ankara, Turkey
1982-Ph.D. Caltech

Positions: 1982-1984 Associate Experimental Physicist, Caltech
9/84-7/87 Research Scientist, MIT
7/87-present Staff Scientist, Caltech

Research:

- Conducted advanced experimental research in the area of gravitational and gravitational radiation.
- Conducted work on the "Digital Orrery" Project.
- Designed and constructed high speed computing machinery to solve physical problems, at MIT AI Laboratory.
- Completed the layout of the Scheme86 processor.
- Completed the design and the feasibility of the Fast Floating-Point Processor.

Jefferson H. Harman

Born: September 10, 1937, U.S.A.
U.S. Citizen

Present Position: Principal Electronic Engineer
California Institute of Technology

Education: 1959-B.E.E. Georgia Tech
1969-M.S. U.C.L.A.

Positions: 1959-1963 Junior Engineer, Collins Radio Company
1963-1965 Engineer, Spacecraft, Inc.
1965-1966 Engineer, Beckman Instrument Company
1966-1967 Project Engineer, Raytheon Computer
1967-1968 Group Leader, Analog Circuits; Allen Electric, UTI Division
1968-1970 Principal Member/Technical Staff, Scientific Data Systems, Inc.
1970-1973 Manager of Servomechanism Design, Wangco, Inc.
1973-1974 Manager of Electronics, General Systems International, Inc.
1974-1981 Chief Engineer, Director of R and D, Persci, Inc.
1974-1981 Director of Electrical Engineering, Persci, Inc.
1981-1983 Principal Consultant, Cambrian Consultants, Inc.
1983-1986 President, Harman Engineering Labs, Inc.
12/86-10/87 Electronic Engineer, Caltech
10/87-present Principal Electronic Engineer, Caltech

Research:

Industrial research leading to the following U.S. patents:
3,143,707 Gated Dual Identical Channel AGC
4,027,217 Speed Control for DC Motors
4,270,073 Position Control in Disk Drive Systems
4,300,174 Guard Band Control for Magnetic Disks
4,306,257 Processing Read-back Signals in Magnetic Disks
Other patents pending

Professional Societies:

Institute of Electrical and Electronics Engineers (IEEE)

Andrew D. Jeffries

Born: December, 1951
U.S. Citizen

Education: 1983 Ph.D. Physics, Massachusetts Institute of Technology
Thesis title: "Angular and Spectral Distortions of the Cosmic Background"
1977 A.B. Physics, University of California, Berkeley

Present

Position: Experimental Research Physicist, MIT Center for Space Research

Positions: 1985 Research Staff, MIT Center for Space Research
1983 Postdoctoral Associate, MIT Physics
1979 Research Assistant, MIT Physics
1978 Teaching Assistant, MIT Physics

Other 1985- Senior Thesis Advisor Physics, Electrical Engineering
Activities: 1986- Project Supervisor, Modern Optics Laboratory
1984- Undergraduate Research Opportunity Supervisor
1982- Freshman Academic Advisor

Professional

Societies: American Physical Society

Research: Gravitational Wave Astronomy and Detectors
Modern Optics, Laser Physics
Experimental Cosmology, Cosmic Background Radiation

Paul S. Linsay

Born: August 13, 1947, Germany (FRG)
U.S. Citizen

Present Position: Principal Research Scientist, M.I.T.

Education: 1969—B.S.— M.I.T.
1970—M.S. University of Chicago
1976—Ph.D. University of Chicago

Positions: 1969—1970 Teaching Assitant, University of Chicago
1970—1976 Research Assistant, University of Chicago
1976—1979 Research Fellow in Physics, Caltech
1979—1982 Research Scientist, M.I.T.
1982— Principal Research Scientist, M.I.T.

Research: Particle Physics: Kaon physics, neutrino scattering
Gravitational Wave Astronomy
Nonlinear Dynamics
Co-investigator (1980—) NSF grants supporting gravitational wave astronomy. Principal Investigator (1985—) ONR grant supporting studies in nonlinear dynamics.

Professional Societies: American Physical Society
American Astronomical Society

Jeffrey C. Livas

Born: March 27, 1959. Palmer, MA.
U.S. Citizen

Present Positions: Postdoctoral Associate, Massachusetts Institute of Technology
Scientist, MIT/Caltech Laser Interferometer
Gravitational Wave Observatory (LIGO) Project

Education: 1981 - S.B. Massachusetts Institute of Technology
1987 - Ph.D. Massachusetts Institute of Technology

Positions: 1981 - 1987 Research Assistant, Physics Department, MIT
1980 - 1981 Calculus recitation instructor, Concourse Program, MIT

Research:

Thesis research on experimental gravitational wave detection. Developed data analysis techniques to search for periodic sources of unknown period and direction.

Other Activities: 1986-present Educational Counselor
1982-1986 Freshman Adviser
1982-1986 Undergraduate Admissions Reader

Professional Societies: American Physical Society
American Association for the Advancement of Science
Sigma Xi

Boude C. Moore

Born: March 11, 1925, Nagasaki, Japan
U.S. Citizen

Present

Position: Engineer, California Institute of Technology

Education: 1948-B.S.E.E. California Institute of Technology
1949-M.S.E.E. California Institute of Technology

Positions: 1943-1946 Radio Technician, U.S. Navy
1947 Electronics Technician, Jet Propulsion Laboratory
1948 Draftsman, Northrop Aircraft
1948-1949 Laboratory Assistant, Caltech
1949-1953 Instrumentation Engineer, Douglas Aircraft
1953-1965 Group Leader, Douglas Aircraft
1965-1974 Branch Chief, McDonnell-Douglas Co.
1974-1984 Section Chief, McDonnell-Douglas Co.
1984-1987 Consultant (self-employed)
1987 Engineer, LIGO Project, Caltech

Research:

Studied vacuum technology, both theoretical and experimental. Principal Investigator on NASA study of Molecular Wake Shield. Participated in the analysis and procurement of the McDonnell-Douglas 39-foot diameter space simulation chamber. Provided similar support for chambers at Westinghouse, RCA, Rockwell, etc., also the Library of Congress book preservation project.

Other

Activities: Chairman, AIAA Working Group on Space Simulation, 1980
Member, AIAA Technical Committee on Ground Test and Simulation, 1973-1976
Member, AIAA Outlook for Space Committee, 1976
Chairman, Test Laboratory Managers Working Group, 1979
Member, ASTM E21 Committee on Space Simulation, 1981-1984

Professional

Societies: American Vacuum Society
American Institute of Aeronautics and Astronautics
Institute of Electrical and Electronics Engineers

Peter R. Saulson

Born: October 30, 1954, Baltimore, Maryland

Present

Position: Principal Research Scientist, MIT Department of Physics

Education: 1976-A.B. Magna cum laude in Physics, Harvard University
1978-M.A. Physics, Princeton University
1981-Ph.D. Physics, Princeton University
Thesis: "Optical and Infrared Search for Massive Halos of Spiral Galaxies"

Positions: 1978-1980 Assistant in Instruction, Freshman Lab,
Princeton University
1980-1981 Assistant in Instruction, Modern Physics, Princeton University
1981-1984 Postdoctoral Research Associate, MIT Department of Physics
1984-1985 Sponsored Research Technical Staff, MIT Center for Space Research
1986 Recitation Instructor, Freshman Physics, MIT
1985-present Principal Research Scientist, MIT Department of Physics

Research: Observational Cosmology
Gravitational Wave Astronomy

Professional

Societies: American Astronomical Society

Robert E. Spero

Born: September 12, 1951. California
U.S. Citizen

Present Position: Member of the Professional Staff,
California Institute of Technology (Caltech)

Education: 1973-B.S. U.C.L.A.
1976-M.A. U.C. Irvine
1979-Ph.D. U.C. Irvine

Positions: 1976-1979 Research Assistant
U.C. Irvine
1980-1983 Research Fellow
Caltech
1983-present Member of the Professional Staff
Caltech

Research:

Precision measurement of small forces and displacements, including use of laser-interferometry and torsion balance.
Stabilization of lasers and resonant optical cavities.
Analog and digital electronics for servocontrol and signal processing.
High vacuum technology.
Precision metrology.
Seismic isolation.

APPENDIX A

THE PHYSICS OF GRAVITATIONAL WAVES, AND COMPARISON OF SOURCE STRENGTHS WITH DETECTOR SENSITIVITIES

This appendix presents a detailed discussion of the issues raised in Sections II.A, II.B, and II.C of the proposal. For still greater detail see Reference [A-1].

A.1 The Physics of Gravitational Waves

Gravitational waves are predicted by general relativity theory and by all other relativistic theories of gravity, and all the theories agree, in rough order of magnitude, on the strengths of the waves to be expected from astrophysical sources. Although gravitational waves have not yet been observed directly, the effect of the back-action of gravitational-wave emission on one source (the orbital decay of the binary pulsar PSR 1913+16) has been measured and agrees with general relativity's predictions to within the experimental error of several per cent [A-2]. The primary goal of the LIGO Project is to detect gravitational waves directly and use them to test the fundamental laws of physics and to open a new window onto the astrophysical universe.

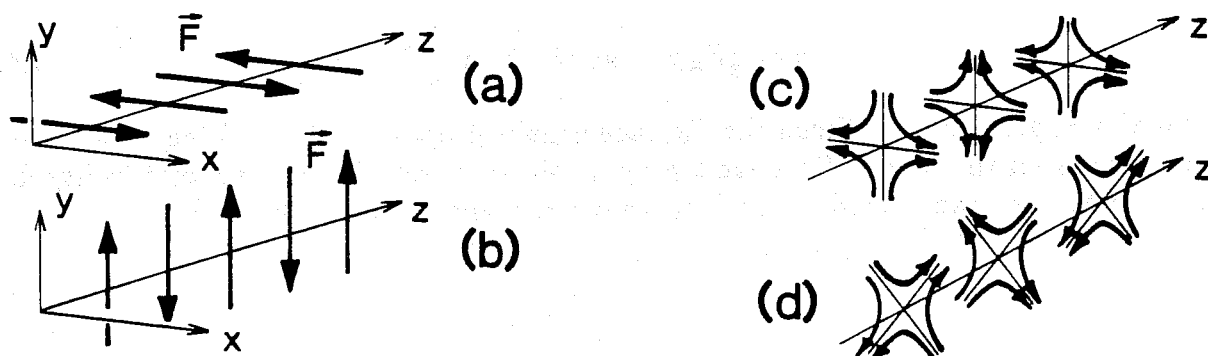

Figure A-1 Left half: The Forces produced on charged particles by an electromagnetic wave propagating in the z direction: (a) for x -polarization, and (b) for y -polarization. Right half: The forces on massive particles produced by a gravitational wave propagating in the z direction: (a) for $+$ polarization, and (b) for \times polarization.

The forces produced by gravitational waves. Just as an electromagnetic wave pushes a charged particle that initially is at rest back and forth in a direction transverse to the wave's propagation (figures A-1a and A-1b), so also a gravitational wave pushes a massive particle, initially at rest, back and forth transversely (figures A-1c and A-1d). The figures show the lines of force as measured in a local "proper reference frame", whose time coordinate t is equal to the proper time ticked by physical clocks and whose orthogonal spatial coordinates (x, y, z) measure proper (physical) distance. For a gravitational wave the force on a particle of mass m at location (x, y, z) is the sum of contributions from two polarizations: the $+$ ("plus") polarization (Figure A-1c) with force

$$\vec{F} = \frac{1}{2} m \ddot{h}_+ (x \vec{e}_x - y \vec{e}_y) \quad (A.1a)$$

and the \times ("cross") polarization (Figure A-1d) with force

$$\vec{F} = \frac{1}{2} m \dot{h}_{\times} (y \vec{e}_x + x \vec{e}_y). \quad (\text{A.1b})$$

Here dots denote time derivatives, \vec{e}_x and \vec{e}_y are unit basis vectors in the x and y directions, and h_+ and h_{\times} are dimensionless *gravitational-wave fields*, which propagate in the z -direction at the speed of light

$$h_+ = h_+(t - z/c), \quad h_{\times} = h_{\times}(t - z/c). \quad (\text{A.2})$$

Notice that the gravitational force fields (A.1c,d) are quadrupolar and are transverse to the waves' propagation direction.

If a test particle at (x, y, z) is unconstrained by other forces, then it will accelerate by an amount $\delta \vec{x} = \vec{F}/m$ in response to the gravitational wave, and its resulting displacement will be

$$\delta x = \frac{1}{2} h_+ x, \quad \delta y = -\frac{1}{2} h_+ y, \quad \delta z = 0 \quad (\text{A.3a})$$

for the $+$ polarization and

$$\delta x = \frac{1}{2} h_{\times} y, \quad \delta y = \frac{1}{2} h_{\times} x, \quad \delta z = 0 \quad (\text{A.3b})$$

for the \times polarization. Since the displacement is proportional to the separation of the particle from the origin of the local proper reference frame, with proportionality factor h_+ or h_{\times} , one can regard h_+ and h_{\times} as dimensionless "strains of space".

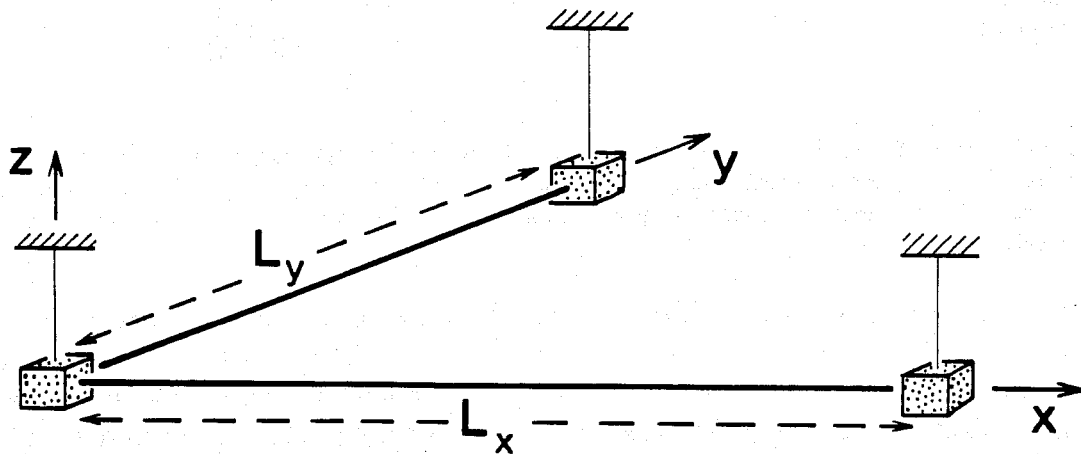

Figure A-2 Schematic diagram of a laser interferometer gravitational wave detector.

Effect of the wave on an Interferometric Detector. Figure A-2 is a schematic diagram of an interferometric detector of the type to be operated in the LIGO. Three masses hang by wires from overhead supports at the corner and ends of an "L". We

shall denote by L the lengths of the arms of the “L” and shall place the origin of a proper reference frame at the corner mass as shown. If a gravitational wave propagates vertically (z -direction), and has its $+$ polarization axes parallel to the detector’s arms, and has a frequency f high compared to the one-Hertz swinging frequency of the masses, then the wave will move the end masses back and forth relative to the corner mass in just the same manner as if the end masses were free (the pendulum restoring force does not have time to act). The resulting wave-induced changes in the x -arm and y -arm lengths [equation (A.3a)] will be $\delta L_x = \frac{1}{2}h_+L$ and $\delta L_y = -\frac{1}{2}h_+L$; i.e. they will be equal and opposite. These changes are monitored by laser interferometry: Laser beams, sent from the center mass down the two arms and reflected off mirrors on the end masses, will return to the corner with a relative phase change $\Delta\Phi$ that is proportional to the difference in arm lengths,

$$\Delta\Phi = 2\pi\Delta L/\lambda_l, \quad \text{where } \Delta L \equiv \delta L_x - \delta L_y = h_+(t)L. \quad (\text{A.4})$$

Here λ_l is the light’s wavelength. By interfering the beams one can monitor this phase change and thence monitor the gravitational wave field $h_+(t)$. A variety of interferometric optical systems have been proposed and developed for performing the monitoring. The most promising ones are discussed in Parts V and VI and Appendices F, G, and H. [*Side remark:* One might worry that the gravitational wave will interact with the laser beams and thereby alter the standard phase-change relation $\Delta\Phi = 2\pi\Delta L/\lambda_l$. Not so if one uses, as we have, a rigid, Cartesian coordinate system whose coordinate lengths are unaffected by the wave. Only if one uses “rubbery coordinates” (e.g. the “transverse-traceless coordinates” introduced in many textbooks) need one worry about interaction of the gravitational wave with the light.]

If the wave, instead of coming in vertically, comes in from a direction with polar angles (θ, ϕ) relative to the Cartesian coordinates of Figure A-2 (cf. Figure II-1 in Section II.A), and if we take one of the $+$ state’s polarization axes to be horizontal, then straightforward algebra shows that the forces (A.1) produce the relative arm-length change

$$\Delta L/L = F_+(\theta, \phi)h_+(t) + F_\times(\theta, \phi)h_\times(t), \quad (\text{A.5a})$$

where F_+ and F_\times are the detector’s quadrupolar beam pattern functions

$$F_+ = \frac{1}{2}(1 + \cos^2 \theta) \cos 2\phi, \quad F_\times = \cos \theta \sin 2\phi. \quad (\text{A.5b})$$

Note that the beam patterns are very broad. This means that the relative responses of different detectors, with different orientations, will give rather poorer information about source directions than the time-of-flight between widely separated detectors.

Measurement of the graviton’s rest mass and spin. Quantum field theory tells us that classical waves are carried by quanta (photons for electromagnetic waves and gravitons for gravitational waves), and that the rest masses and spins of the quanta can be inferred from the propagation speeds and polarization properties of their waves:

The propagation speed will be precisely the speed of light if and only if the quanta have zero rest mass; otherwise it will be slower. Thus, one goal of the LIGO Project

is to detect gravitational waves from a supernova outburst in the nearest large cluster of galaxies, the Virgo Cluster, and compare the waves' arrival time with the beginning of the optical outburst. Since the distance to Virgo is about 30 million light years, even with an optical time resolution of only one day, one could infer that the light and gravitational waves propagated with the same speed to within a fractional error of (one day)/(30 million light years) $\sim 10^{-10}$, and one thereby could place on the graviton rest mass a limit of $\sim 10^{-5} \times$ (the energy of a 1000 Hz graviton) $\sim 10^{-16}$ eV. If neutrinos could also be detected, the time resolution for both neutrinos and gravitational waves could be about one millisecond; and if their onsets were that close together, one would infer equal speeds to within $\sim 10^{-18}$ and corresponding rest mass limits of $\sim 10^{-20}$ eV for the graviton, and $\sim 10^{-2}$ eV for the neutrino.

The spin S of the quantum that carries a classical wave determines the "return angle" of the wave's force field: Rotate the force field (Figure A-1) about the wave's propagation direction. The minimum angle of rotation that brings the field back to its original orientation is its return angle θ_{ret} and is equal to (360 degrees)/ S . For the electromagnetic wave of Figures A-1a and A-1b, θ_{ret} is 360 degrees, so the photon must have spin one; for the gravitational wave of Figures A-1c and A-1d, θ_{ret} is 180 degrees, so the graviton must have spin two. Correspondingly, one goal of the LIGO project is to determine the return angle for gravitational waves by simultaneous measurements with several different detectors (in a world-wide network) that have several different orientations. Since most other relativistic theories of gravity predict a mixture of spin-two, spin-one, and/or spin-zero gravitons [A-3], such a measurement would be a powerful test of whether general relativity is correct.

The strengths of cosmic gravitational waves. Energy conservation dictates that the wave fields h_+ and h_\times die out as $1/(\text{distance to the source}) = 1/r$. Just as an electromagnetic wave is produced by oscillating multipole moments of a charge distribution, so also a gravitational wave is produced by oscillating multipole moments of a mass distribution. In the electromagnetic case the monopole moment cannot oscillate because it is the source's total charge and charge is conserved; and, consequently, the radiation is typically dipolar. Similarly, in the gravitational case the monopole moment cannot oscillate because it is the source's total mass and mass is conserved; moreover, the mass dipole moment cannot oscillate because its time derivative is the source's total momentum and momentum is conserved; and, consequently, gravitational radiation is typically quadrupolar. Dimensional considerations then dictate that $h_+ \sim h_\times \sim (G/c^4) \ddot{Q}/r$ where G is Newton's gravitation constant, c is the speed of light, Q is the quadrupole moment, and dots denote time derivatives. Since the quadrupole moment is of order the mass of the source times the square of its size, \ddot{Q} is of order the mass times the square of the source's internal velocities, i.e. of order the source's internal kinetic energy—or, more precisely, that part of the kinetic energy associated with oscillatory, nonspherical motions, $E_{\text{kin}}^{\text{ns}}$:

$$h_+ \sim h_\times \sim \frac{G}{c^4} \frac{E_{\text{kin}}^{\text{ns}}}{r} \sim 10^{-20} \left[\frac{E_{\text{kin}}^{\text{ns}}}{M_\odot c^2} \right] \left[\frac{30 \text{ million light years}}{r} \right]. \quad (\text{A.6})$$

Here M_\odot is the mass of the sun and 30 million light years is the distance to the Virgo Cluster. Equation (A.6) is a correct order-of-magnitude estimate not only for general

relativity, but also for other theories of gravity; and it suggests that the strongest extragalactic waves bathing the earth are not likely to exceed 10^{-20} .

Characteristics of the strongest sources. The strongest sources are those for which the nonspherical, internal kinetic energy is largest, which means those with large masses and large internal velocities. Since the internal velocities are generated by internal gravity, large internal velocities means large internal gravity, which means compact size. Thus it is that the strongest sources are likely to be black holes and neutron stars—e.g. the violent births of black holes and neutron stars in stellar implosions, the inspiral and coalescence of binary neutron stars and black holes in distant galaxies, and the rotation of nonaxisymmetric neutron stars (pulsars) in our own galaxy.

The frequencies of cosmic gravitational waves. The characteristic frequencies of vibration and rotation for neutron stars are less than or of order a few kilohertz; and those for a black hole of mass M are

$$f \sim \frac{10 \text{ kHz}}{M/2M_{\odot}} \quad (\text{A.7})$$

(where $2M_{\odot}$ is the smallest possible mass for a black hole that forms by stellar collapse). Thus, the strongest waves are likely to lie at frequencies of 10 kHz and below. The LIGO is designed to work from 10 kHz down to the lowest frequencies at which one can isolate the detectors from earth vibrations, ~ 10 Hz—a range in which a rich variety of sources should exist. At yet lower frequencies, where there should also be interesting sources, one must use space-based detectors—the most promising of which will be LIGO-type detectors that might fly in space in the early 21st century [A-4]. The LIGO Project will provide an important base of technology and experience for those future detectors.

Penetrating power of gravitational waves. Because the strongest sources of gravitational waves are compact concentrations of highly dynamical mass, they typically will lie in regions obscured by surrounding matter (e.g. in the core of a supernova explosion or at the center of a galaxy or in the big-bang origin of the universe). Fortunately, gravitational waves are highly penetrating. For example, whereas neutrinos scatter many times in emerging from the center of a supernova and photons cannot get out at all, gravitational waves should emerge with impunity. Similarly, whereas photons from the big bang (the cosmic microwave radiation) last scattered off matter when the universe was about one million years old and neutrinos last scattered when it was a few seconds old, primordial gravitational waves should have last scattered near the Planck time, $\sqrt{G\hbar/c^5} \sim 10^{-43}$ seconds, when the initial conditions of the universe were being set by the (little understood) laws of quantum gravity [A-5].

Electromagnetic information as a poor predictor of cosmic gravitational waves. Electromagnetic waves studied by astronomers are almost always incoherent superpositions of the emissions from a huge number of molecules, atoms, or charged particles. In contrast, cosmic gravitational waves are produced by the coherent, bulk motions of huge amounts of mass-energy (either in the form of matter as in neutron stars, or in the form of vibrating, nonlinear spacetime curvature as in colliding black holes). This difference of emission mechanism, together with the fact that the strongest gravitational wave sources are probably opaque to photons, serves as a warning that our present photon-

based knowledge of the universe may be a rather poor guide as to what gravitational-wave astronomy will bring. On one hand, we cannot estimate with confidence how sensitive must be the LIGO's detectors in order to discover waves. On the other hand, when waves are discovered, they are likely to bring surprises. Indeed, it seems likely that gravitational radiation will produce a revolution in our understanding of the universe comparable to that which came from radio waves in the 1950s and 1960s [A-6].

The information carried by gravitational waves. Gravitational waves carry substantial information about their sources. The total information carried to earth is embodied in the celestial coordinates (α, δ) of the source on the sky, plus the two "gravitational wave forms" $h_+(t)$ and $h_\times(t)$ evaluated at the location of a detector. The LIGO detectors are broad-band instruments, designed to measure the wave forms in the time domain with a high-frequency cutoff around 10 kHz and a seismic-noise-induced low-frequency cutoff, which in present prototypes is around 400 Hz and will be pushed continually downward toward 10 Hz over the coming years. A goal of the LIGO project, in cooperation with other detectors in a world-wide network, is to extract the full information, α , δ , $h_+(t)$, and $h_\times(t)$ from the waves; and, where possible, to cross-correlate that information with data from other kinds of radiation.

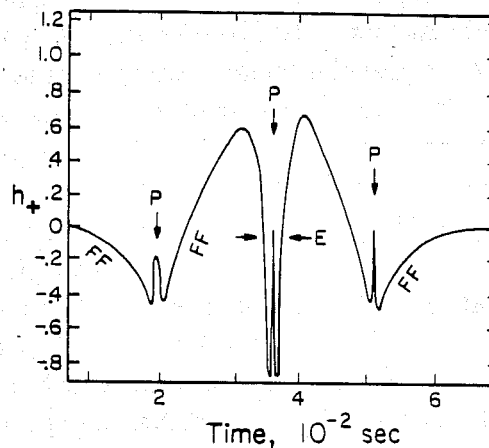

Figure A-3 The gravitational waveform produced by one scenario for the collapse of a star to form a neutron core, as computed in a numerical simulation by Richard A. Saenz and Stuart L. Shapiro [A-7].

Extraction of information from a wave form. Figure A-3 shows a wave form $h_+(t)$ computed several years ago by numerical simulation of a specific kind of source [A-7]. Without knowing the details of the simulation one can infer the following: (i) Because the shortest time scales present in the wave form are ~ 0.5 msec, the source must be either a neutron star or a several-solar-mass black hole. Assuming, as usually will be the case, that the radiation is predominantly quadrupolar, one can double-time-integrate the waveform to get the time evolution of the source's quadrupole moment. One then notices that the segments of the waveform marked *FF* have the shapes, $h_+ \propto (t - \text{const})^{-2/3}$ that one expects from nonspherical, free-fall motion; and the sharply reversed peaks

marked P are what one expects from a sharp acceleration in the direction opposite to the free fall. The natural and correct interpretation is that these waves are from a stellar collapse that formed a neutron core which bounced three times. The fact that the three sharp peaks are all in the same direction (up, not down) indicates that the sharp bounces were all along the same axis. Surely the other axis or axes should have bounced as well, or at least stopped their collapse; so there should be at least one sharp peak in the down direction. Indeed there is; it is superposed on the central up peak (region labeled E). The natural and correct interpretation is that the collapsing star was centrifugally flattened by rotation; its pole collapsed fast and bounced three times (up peaks P) while its equator collapsed more slowly and bounced once (down peak E).

This wave form is not a firm prediction; it is merely one of many different wave forms that have been computed based on many different scenarios for stellar collapse. Neutron-star physics is so complicated—especially in the highly dynamical, shock-wave-endowed situations that produce strong gravitational waves—that theorists in the early years of gravitational wave astronomy are likely to be relegated to the task of interpreting the observed waveforms, as above, rather than predicting them with confidence. From those interpretations we should learn much about the uncertain physics that governs dynamical neutron stars.

Wave-form tests of black-hole physics. Because black holes are made of pure vacuum gravity, their dynamics can be computed with far greater confidence (if one believes in general relativity) than the dynamics of neutron stars. For example, numerical relativity experts expect, by the early 1990s, to compute in detail the waveforms produced when two black holes orbiting each other spiral together and coalesce [A-8]—a type of source that the LIGO may ultimately be able to see throughout the universe (Figure A-4a below). A detailed agreement between the computed and observed wave forms would simultaneously confirm the existence of black holes in the real universe and test general relativity's predictions for the behavior of gravity in highly nonlinear, dynamical situations.

The signal-to-noise ratio required for wave-form studies. One might worry that the LIGO detectors will never have good enough signal-to-noise ratio to see the details of the wave forms. On the contrary, if the LIGO is sensitive enough to make detections at all, it will be sensitive enough for wave-form studies. This is because to detect so rare an event as a stellar collapse or binary coalescence in the midst of the detector's Gaussian noise will require an amplitude signal-to-noise ratio of 5 or more; and if the signal-to-noise is high enough to be confident the event was real, that full ≥ 5 signal-to-noise can be used for wave-form extraction.

The use of waves to probe the large-scale structure of the universe. As we shall see, the coalescence of neutron-star and black-hole binaries is a promising source for detectors of the second or third generation in the LIGO. For such coalescences the wave-form signatures (a sinusoid with frequency sweep from low to high) are so clean and the wave strength is so firmly predictable, that they could act as a "standard candle" with which to measure the large-scale structure of the universe (the Hubble expansion rate and deceleration parameter) [A-9]; cf. the paragraph preceding Eq. (A.10) below.

A.2 Scientific Payoff from the LIGO Project

From the above discussion we can cull a list of scientific payoffs that might come from the LIGO Project. That list was presented in Part II; and we reproduce it here for ease of reading. The LIGO Project is being designed and managed, so far as possible, in such a way as to maximize the likelihood that some or most of these payoffs will be achieved.

Possible Payoffs for Physics

- The observational discovery of gravitational waves.
- Measurement of the rest mass and spin of the graviton: do they agree with general relativity's predictions, $m = 0$ and $S = 2$?
- Verification (by comparing theoretical and observed wave forms) that black holes exist and that their dynamics are as predicted by general relativity. Thereby test general relativity for the first time in the domain of highly nonlinear, dynamic gravity.

Some Possible Payoffs for Astronomy and Astrophysics

- Open up a new window onto the universe, a window that is almost certain to bring surprises and that may bring a revolution comparable to that which came from the radio window in the 1950s and 60s.
- Study the behaviors of neutron stars in highly dynamical situations. Thereby extract information about the uncertain physics that governs neutron stars.
- Use the waves from binary coalescences as "standard candles" for the determination of the Hubble expansion rate and deceleration parameter of the universe.
- Detect primordial gravitational waves from the big bang, and from them extract information about the initial conditions and earliest stages of evolution of the universe.

A.3 Estimates of the Strengths of the Waves at Earth and Comparison with Anticipated LIGO Sensitivities

Whether these payoffs can be achieved will depend, primarily, on whether detectors in the LIGO can reach the required sensitivities. The best estimates of the required sensitivities come from astrophysical source-strength calculations. Unfortunately, those calculations, being based on our electromagnetic understanding of the universe, are very uncertain: With the single exception of binary-neutron-star coalescences (see below), for each type of source either (i) the strength of the source's waves for a given distance from earth is uncertain by several orders of magnitude, or (ii) the rate of occurrence of that type of source, and thus the distance to the nearest one, is uncertain by several orders, or (iii) the very existence of that type of source is uncertain.

The source strength calculations are summarized by the thin curves and lines in Figures A-4a (short bursts), A-4b (periodic waves), and A-4c (stochastic background). For full details of the assumptions and calculations that underlie these figures and for extensive references to the literature see section 9.4 of Reference [A-1]. Here we shall give only a brief overview.

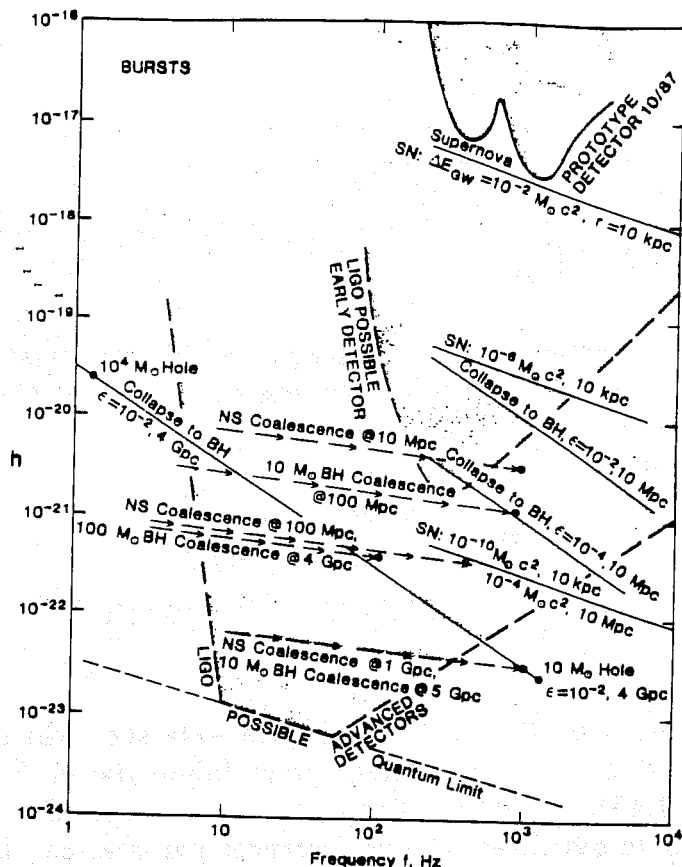

Figure A-4a The estimated wave strengths for various gravitational-wave bursts [thin curves and arrows]; and benchmark sensitivities [thick curves and stippled strips atop them] for interferometric detectors today and in the proposed LIGO.

Gravitational wave bursts (Figure A-4a)

Gravitational wave bursts that have been modeled by theorists last for no more than a few thousand cycles, and usually no more than three cycles. We shall describe such a burst by a characteristic frequency f (horizontal axis of Figure A-4a) and by a characteristic dimensionless amplitude h_c , which is defined in Reference [A-1, Equation (31)], in terms of optimal signal processing of a gravitational-wave detector's output and an average over source orientations, and which is approximately equal to the amplitude of the wave-form oscillations $h_+(t)$ and/or $h_\times(t)$ multiplied by the square root of the the number n of cycles that the burst spends near frequency f . (The factor \sqrt{n} accounts for the ability of the detector to amplify the signal by integrating up the cycles.)

Coalescing neutron-star binaries. Our one moderately (but not highly) certain source is the coalescence of a neutron-star binary system. That coalescence should produce, during the inspiral phase, a "chirp", with characteristic frequency sweeping upward through the LIGO's band from a few tens of Hertz to 1000 Hz in a time of a few minutes. The characteristic amplitude of the inspiral waves for a binary at a given distance is predicted with confidence and accuracy by general relativity [equation (46b)

of Reference A-1]:

$$\begin{aligned}
 h_c &= 0.287 \frac{G(\mu M)^{1/2}}{c^2 r} \left(\frac{\pi G M f}{c^3} \right)^{-1/6} \\
 &= 4.1 \times 10^{-22} \left(\frac{\mu}{M_\odot} \right)^{1/2} \left(\frac{M}{M_\odot} \right)^{1/3} \left(\frac{100 \text{ Mpc}}{r} \right) \left(\frac{100 \text{ Hz}}{f} \right)^{1/6}
 \end{aligned} \tag{A.8}$$

Here μ is the binary system's reduced mass, M is its total mass, r is its distance from earth, and G and c are Newton's gravitation constant and the speed of light. The number of cycles spent near frequency f is

$$\begin{aligned}
 n &\equiv \frac{f^2}{\dot{f}} = \frac{5}{96\pi} \frac{M}{\mu} \left(\frac{c^3}{\pi G M f} \right)^{5/3} \\
 &= 3200 \frac{M/4}{\mu} \left(\frac{M_\odot}{M} \right)^{5/3} \left(\frac{100 \text{ Hz}}{f} \right)^{5/3}
 \end{aligned} \tag{A.9}$$

The arrows at $h\sqrt{n} \sim 10^{-20}$ to 10^{-23} in Figure A-4a show the sweep of such binaries from low frequency to high, for neutron stars (abbreviated *NS* in the figure) with individual masses $1.4M_\odot$ (so $M = 2.8M_\odot$ and $\mu = 0.7M_\odot$). The distance to which one must look in order to see three such coalescences per year can be estimated from the observed statistics of pulsars in our own galaxy: Clark, Van den Heuvel and Sutantyo [A-10] compute for the 3/year distance 100^{+100}_{-40} Megaparsecs with 90 per cent confidence. Schutz [A-11] computes, with "very high confidence", 10 Megaparsecs to 1 Gigaparsec. The arrows in Figure A-3 are for 100 Mpc (best estimate), 1Gpc (most pessimistic estimate) and 10 Megaparsec (most optimistic). [Recall: one parsec is three light years; the center of our galaxy is at 10 kpc, the Virgo cluster is 10 Mpc, and the Hubble distance is 4 Gpc.]

Coalescing black-hole binaries, during their inspiral phase, are described by the same formulas (A.8) and (A.9) as for neutron stars, but their final gravitational-wave burst, as their horizons coalesce and the combined hole then vibrates, will be very different. It is this final burst that will be computed with confidence using supercomputers in the next few years and that, by comparison of theory and experiment, should constitute both a firm proof of the existence of black holes and a powerful test of general relativity. Coalescing black-hole binaries should be more rare than coalescing neutron-star binaries. Most likely their event rate is somewhat larger than one per year out to the Hubble distance of ~ 4 Gpc; but they might not exist at all, and they might be as common as several per year at 100 Mpc. The characteristic amplitudes during the inspiral phase are shown in Figure A-4a for distances of 4 Gpc and 100 Mpc and for several masses.

Coalescing binaries as standard candles. Notice that during the inspiral phase of any compact binary the number of cycles spent near a given frequency [equation (A.9)] and the characteristic amplitude [equation (A.8)] depend on the same combination of masses, $\mu M^{2/3}$. Correspondingly, as Schutz [A-9] has pointed out, one can solve directly from the observational data for the distance r to the source. If one can also identify

the galaxy or cluster of galaxies in which the source lies and get a redshift from its electromagnetic radiation, one therefrom can determine the Hubble expansion rate of the universe and perhaps get a handle on its deceleration parameter.

Supernovae and other stellar collapses that form neutron stars. The rate of occurrence of supernovae is fairly well determined (about one every 30 years per galaxy as large as our own; several per year in the Virgo cluster). Stellar collapses that produce no bright optical display could be up to ten times more numerous, or might not occur at all. Unfortunately, the strengths of the waves from a stellar collapse at a given distance are highly uncertain. If the collapse is spherical, no waves are produced at all; if it is highly nonspherical, as much as one per cent of the rest mass of the collapsing stellar core could come off in gravitational waves. Even the characteristic frequency of the waves is uncertain; various plausible models have given frequencies anywhere from a few hundred Hertz to 10 kHz. The characteristic amplitude h , as a function of the characteristic frequency f , the total energy ΔE_{GW} carried off in gravitational waves, and the distance r to the source is (equation (37) of Reference [A-1]):

$$h \simeq \left(\frac{3}{2\pi^2} \frac{G\Delta E_{\text{GW}}/f}{c^3 r^2} \right)^{1/2} = 2.7 \times 10^{-20} \left(\frac{\Delta E_{\text{GW}}}{M_{\odot} c^2} \right)^{1/2} \left(\frac{1 \text{ kHz}}{f} \right)^{1/2} \left(\frac{10 \text{ Mpc}}{r} \right). \quad (\text{A.10})$$

Figure A-4a shows this characteristic amplitude for collapses that produce neutron stars (labeled "SN" with gravitational-wave outputs of 10^{-2} to 10^{-10} solar masses and distances of our galactic center (10 kpc) and the Virgo Cluster (10 Mpc). Note that the recent supernova in the Large Magellanic Cloud, being 5 times more distant than our galactic center, would have produced

$$h \simeq \frac{1}{2} \times 10^{-18} \left(\frac{\Delta E_{\text{GW}}}{10^{-2} M_{\odot} c^2} \right)^{1/2} \left(\frac{1 \text{ kHz}}{f} \right)^{1/2}. \quad (\text{A.11})$$

Stellar collapses that form black holes produce short wave bursts with characteristic amplitude given by (A.10) and with characteristic frequency $f \sim c^3/5\pi GM \simeq (1.3 \text{ kHz})(10M_{\odot}/M)$. The energy carried off can vary from $\Delta E_{\text{GW}} \sim 0.1Mc^2$ down to zero, depending on the degree of nonsphericity of the collapse. The wave strengths and frequencies shown in Figure A-4a are for efficiencies $\epsilon \equiv \Delta E_{\text{GW}}/Mc^2$ of 10^{-2} and 10^{-4} and distances of 10 Mpc (Virgo) and 4 Gpc (Hubble).

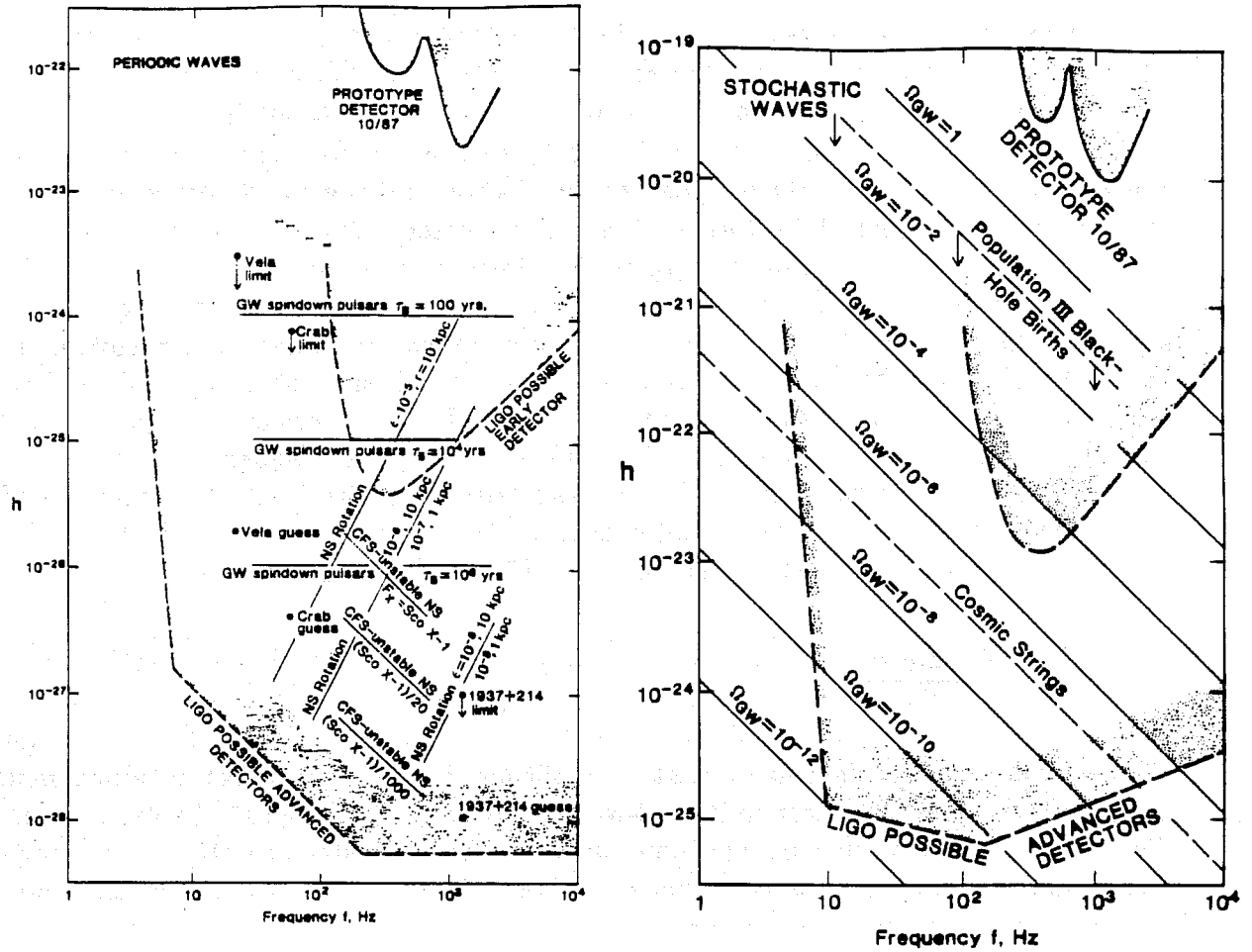

Figure A-4b,c Same as Figure A-4a, but for periodic waves (b), and for stochastic background waves (c). In both figures the detectors are assumed to use an integration time of 10^7 seconds.

Periodic Gravitational Waves (Figure A-4b)

Periodic Gravitational Waves are characterized by the amplitude h of the wave forms' sinusoidal oscillations (vertical axis) and their frequency (horizontal axis). The sources shown in Figure A-4b are all *non-axisymmetric, rotating neutron stars* in our own galaxy. The number of neutron stars in our galaxy is $\geq 10^8$; but most may rotate so slowly and/or be so axisymmetric as to be poor gravitational-wave sources. The dependence of the gravitational-wave amplitude on the neutron star's moment of inertia I_{zz} about the rotation axis, its distance r from earth, its frequency f , and its ellipticity in the equatorial plane $\epsilon = (Q_{xx} - Q_{yy})/I_{zz}$ (where Q_{jk} is its quadrupole moment) is [equation (55) of Reference A-1]

$$h = 8\pi^2 \sqrt{2/15} \frac{\epsilon I_{zz} f^2}{r} = 7.7 \times 10^{-20} \epsilon \left(\frac{I_{zz}}{10^{45} \text{g cm}^2} \right) \left(\frac{f}{1 \text{ kHz}} \right)^2 \left(\frac{10 \text{ kpc}}{r} \right). \quad (\text{A.12})$$

This amplitude is shown in Figure A-4b for a distance of 10 kpc (the center of our galaxy), a moment of inertia of 10^{45} (all neutron stars should be within a factor ~ 3 of this), and a range of plausible ellipticities, $\epsilon \leq 10^{-5}$.

Known pulsars. The large dots in Figure A-4b are known pulsars, for which the amplitudes are uncertain by ~ 5 orders of magnitude because we do not know the stars' ellipticities. For each pulsar are shown (i) a best guess of h based on all present knowledge; and (ii) an upper limit, based on the observed slow down rate of the star's rotation and the (somewhat unlikely) assumption that the slow down is due to gravitational wave emission rather than electromagnetic emission; see section 9.4.2b of Ref. [A-1].

Gravitational-spindown neutron stars. Each horizontal line in Figure A-4b shows the h of the brightest member of a hypothesized population of rotating neutron stars that are spinning down due to gravitational radiation reaction rather than due to electromagnetic emission [A-12]. Each line is for a fixed mean time τ_B between births of those neutron stars; and the frequency-independent amplitude is [equation (57) of Ref. A-1]

$$h \simeq \left[\frac{4}{3} \frac{GI_{zz}}{c^3 R_G^2 \tau_B} \right]^{1/2} \sim 1 \times 10^{-25} \left(\frac{10^4 \text{ years}}{\tau_B} \right)^{1/2}. \quad (\text{A.13})$$

where $I_{zz} \sim 10^{45} \text{ g cm}^2$ is the star's moment of inertia and R_G is the radius of our Galaxy's disk.

Chandrasekhar-Friedman-Schutz Instability. The rightward slanted lines in Figure A-4a are neutron stars that have been spun up by accretion from a companion, until they became unstable against nonaxisymmetric perturbations (the "Chandrasekhar-Friedmann-Schutz" [A-13] or CFS instability). These neutron stars would now be sources of X-rays due to the accretion and gravitational waves due to their nonaxisymmetry, and their gravitational wave amplitudes would be proportional to the square root of their X-ray luminosities, F_X ([A-14], equation (53) of Reference A-1):

$$h \simeq 2 \times 10^{-27} \left(\frac{300 \text{ Hz}}{f} \right)^{1/2} \left(\frac{F_X}{10^{-8} \text{ erg/cm}^2 \text{ sec}} \right)^{1/2}. \quad (\text{A.14})$$

This amplitude is shown in Figure A-4a for X-ray luminosities as fractions of that of the brightest candidate for such an object, *Sco X-1*. NASA is presently considering a proposal [A-15] for an X-ray satellite, the X-ray Timing Explorer (XTE), which, among other things, would search for X-ray modulations that might be due to the CFS instability. Any observed modulations would be cross-correlated with the outputs of gravitational wave detectors.

Stochastic Waves (Figure A-4c)

Stochastic gravitational waves are characterized in Figure A-4c by the amplitude h of the fluctuations of h_+ and h_\times in a bandwidth Δf equal to the frequency f at which one searches; cf. section 9.4.3a of Reference [A-1].

Primordial gravitational waves. The most interesting stochastic background would be that from the *big bang*. Its strength is often described in terms of the gravitational-wave energy density $\rho_{\text{GW}}(f)$ in a band $\Delta f = f$ divided by the energy density required to close the universe,

$$\Omega_{\text{GW}}(f) \equiv \frac{\rho_{\text{GW}}(f)}{\rho_{\text{closure}}}, \quad (\text{A.15})$$

which is related to h by [equation (65) of Reference A-1]

$$\begin{aligned} h(f) &= \left[\frac{4G}{\pi f^2} \Omega_{\text{GW}}(f) \rho_{\text{closure}} \right]^{1/2} \\ &= 1.3 \times 10^{-18} \left(\frac{\rho_{\text{closure}}}{1.7 \times 10^{-8} \text{ erg cm}^{-3}} \right)^{1/2} \left(\frac{1 \text{ Hz}}{f} \right) [\Omega_{\text{GW}}(f)]^{1/2} \end{aligned} \quad (\text{A.16})$$

Lines of constant Ω_{GW} are shown in Figure A-4c. Current speculations about gravitational waves from the very early universe would place Ω_{GW} in the range 10^{-4} on downward. These waves almost certainly are not thermalized at $\sim 3K$ like primordial photons because they decoupled from matter at the Planck time, and because their interaction with background spacetime curvature is likely to have produced significant nonadiabatic, frequency-dependent amplification soon after the Planck time (e.g. during the inflationary era). See section 9.4.3d of Reference A-1 for details and references. Pulsar timing [A-16] has produced an observational limit $\Omega_{\text{GW}} \lesssim 10^{-6}$ at the exceedingly low frequency $f \sim 10^{-8}$ Hz, 10 orders of magnitude away from the LIGO frequency band.

Cosmic Strings. Another possible source of stochastic background is the decay of nonsuperconducting, cosmic strings. If such strings, created in a GUT phase transition in the very early universe, actually exist, they are estimated [A-17] to produce

$$\Omega_{\text{GW}} \sim 10^{-7} \left(\frac{\mu}{10^{-6}} \right)^{1/2} \quad (\text{A.17})$$

throughout the LIGO frequency band [equation (68) of Reference A-1]. Here μ is G/c^2 times the string's mass per unit length, and a value $\mu \sim 10^{-6}$ is suggested both by fundamental theory and by that value's success in producing from strings possible seeds for galaxy formation [A-17].

Population III Black-Hole Births. Stochastic waves could also result from a superposition of emissions from the deaths, long ago, by stellar collapse to form black holes, of a pre-galactic population of massive stars ("Population III stars") [A-18]. Such a population has been hypothesized to help explain the observed abundances of the elements in very old stars. Figure A-4c shows an upper limit [A-18] on the plausible strengths of such Population III waves—which, of course, might not exist at all.

Sensitivities of Detectors in the LIGO

Characterization of detector sensitivities. Internal noise in an interferometric detector (discussed in detail in Part V) causes the fractional arm length difference, $\Delta L/L$, as inferred from the detector's readout, to fluctuate stochastically in time. Those fluctuations are characterized statistically by their spectral density $S_{\Delta L/L}(f)$ as a function of frequency f . It is conventional in this field to denote the square root of that spectral density by

$$\tilde{h}(f) \equiv \sqrt{S_{\Delta L/L}(f)}, \quad (\text{A.18})$$

and call it the detector's *strain per root hertz*. The root-mean-square fluctuations of $\Delta L/L$ at frequency f and in a bandwidth Δf are

$$(\Delta L/L)_{\text{rms}} = \tilde{h}(f) \sqrt{\Delta f}. \quad (\text{A.19})$$

It is these rms fluctuations that compete with the gravitational wave (A.5a) in the output data.

When searching for gravitational wave bursts the relevant bandwidth is $\Delta f \sim f$; and, correspondingly, we plot $h \equiv \tilde{h}(f) \sqrt{f}$ in Figure A-4a (curves at the bottom of the stippled strips) as a measure of detector sensitivity. When searching for periodic sources the relevant bandwidth is $\Delta f \sim 1/\hat{\tau}$, where $\hat{\tau}$ is the integration time; and correspondingly, we plot $h \equiv \tilde{h}(f) \sqrt{1/\hat{\tau}}$ in Figure A-4b (curves at the bottom of the stippled strips) as our measure of detector sensitivity, with $\hat{\tau}$ set equal to 10^7 seconds. When searching for stochastic background one cross correlates two detectors and thereby, if one cross correlates over a band Δf , one achieves an effective bandwidth of order $f/\sqrt{\frac{1}{2}\hat{\tau}\Delta f}$; correspondingly, we plot in Figure A-4c (bottom of stippled curves) $h \equiv \tilde{h}(f)[f/\sqrt{\frac{1}{2}\hat{\tau}\Delta f}]$ with $\Delta f = f$ for the upper two curves, but $\Delta f \ll f$ (see below) for the bottom curve. [To a great extent the choice of bandwidth and the details of the search are fixed in the data analysis. Thus, general purpose data can be collected and then analyzed in a variety of ways for a variety of sources. However, this is not entirely true: some special choices of the interferometric optics produce in the "hardware" special narrow banding of the output, with significant gains of sensitivity at the price of a loss of frequency coverage. These issues are discussed in Part VI and in greater detail in section 9.5.3e of Reference [A-1] (especially Figure 9.13).]

The above measures of detector sensitivity give unity signal to noise ratio when the source direction and polarization are optimal, and when compared to the measures of source strength used in Figures A-4. When one assumes random source direction and polarization the h sensitivity gets degraded by a factor $\sqrt{5}$. If one asks for 90 per cent confidence that the signals are due to waves rather than detector noise, one must demand an amplitude signal-to-noise ratio S/N larger than unity. In the case of stochastic and periodic waves, which are on at all times, and assuming that cross-correlation of two or more detectors has been used to remove all non-Gaussian noise, then that 90%-confidence S/N is 1.7. For bursts which occur on average 3 times per year the 90%-confidence S/N is way out on the tail of the gaussian noise: $S/N \simeq$

$[\ln(2\pi f 10^7 \text{sec})]^{1/2} \simeq 5$. In Figures A-4 the tops of the stippled regions are the 90%-confidence sensitivities for randomly directed and polarized waves:

$$\frac{h_{\text{top of stipple}}}{h_{\text{bottom of stipple}}} = [5 \ln(2\pi f \times 10^7 \text{ sec})] \simeq 5\sqrt{5} = 11 \text{ for bursts, Figure A - 4a}$$

$$= 1.7\sqrt{5} = 3.8 \text{ for periodic and stochastic, Figures - A.4a, b.} \quad (\text{A.20})$$

In Figures A-4 we show three detector sensitivity curves:

Prototype detector. The upper curve-with-stippled-strip is the sensitivity, as defined above, for our prototype detector with 40-meter arms as of October 1987; see Part V for further detail.

Possible early detector in the LIGO. The middle curve-with-stippled-strip in each figure is the sensitivity of a possible detector that might operate soon after the LIGO is completed. The rms-noise curve at the bottom of the stippled region describes, at frequencies above ~ 500 Hz, receivers that are shot-noise-limited, without recycling or resonating or squeezing, with argon ion laser light (reduced wavelength $\lambda_l \equiv \lambda_l/2\pi = 0.0818\mu\text{m}$), with (laser power) \times (photodetector efficiency) $= I_o\eta = 10$ Watts, and with light storage times in each arm of a half gravity-wave period or longer. For two such detectors operating in coincidence, (cf. Equation (123a) of Reference [A-1]):

$$\bar{h}(f) = \left[\frac{2\hbar c \lambda_l}{I_o \eta} \left(\frac{\pi f}{c} \right)^2 \right]^{1/2} = (2.4 \times 10^{-22} \text{ Hz}^{-1/2}) \left(\frac{f}{1000 \text{ Hz}} \right); \quad (\text{A.21})$$

and correspondingly, Equations (123b,c,d) of [A.1]

$$h = \bar{h}\sqrt{f} = 7 \times 10^{-21} \left(\frac{f}{1000 \text{ Hz}} \right)^{3/2} \text{ for bursts,} \quad (\text{A.22a})$$

$$h = \bar{h}\sqrt{10^{-7} \text{ Hz}} = 8 \times 10^{-26} \left(\frac{f}{1000 \text{ Hz}} \right) \text{ for periodic sources,} \quad (\text{A.22b})$$

$$h = \left(\frac{2f}{10^{-7} \text{ Hz}} \right)^{-1/4} \bar{h}\sqrt{f}$$

$$= 2.9 \times 10^{-23} \left(\frac{f}{1000 \text{ Hz}} \right)^{5/4} \text{ for stochastic sources.} \quad (\text{A.22c})$$

Below ~ 500 Hz it is presumed that seismic noise debilitates the performance of these early LIGO detectors. The debilitation shown is a guess, but is quite plausible based on that in the present prototype (upper curve in these figures).

Once the first detector has been operated successfully in the LIGO at something like the sensitivities (A.22), there will follow a succession of generations of ever improving detectors, with the sensitivity levels being pushed continually downward (to smaller h) and leftward (to lower frequencies f) in Figures A-4a,b,c. As a rough measure of where

this might lead after a few years, we have drawn in the figures a lower sensitivity curve which corresponds to the following "Advanced Detector" parameters:

$$\begin{aligned}
L &= (\text{arm length}) = 4\text{km}, \\
\lambda_l &= 0.0818\mu\text{m} \text{ (argon ion laser light)}, \\
I_o\eta &= (\text{laser power}) \times (\text{photodetector sensitivity}) = 100 \text{ Watts}, \\
\mathcal{R} &= (\text{maximum mirror reflectivity}) = 0.9999. \\
m &= (\text{mirror mass}) = 1000 \text{ kg when working at } f \lesssim 100 \text{ Hz}, \\
&\text{photon shot noise dominant at } 100 \text{ Hz} \lesssim f \lesssim 10^4 \text{ Hz}, \\
&\text{quantum limit noise dominant at } 10\text{Hz} \lesssim f \lesssim 100 \text{ Hz}, \\
&\text{seismic noise dominant at } f \lesssim 10\text{Hz}.
\end{aligned} \tag{A.23}$$

It is presumed that light recycling is used for burst searches, with a resulting modest narrow-banding, $\Delta f \simeq f$ of the detector (figure 9.13 of Reference [A-1]). If the optics are adjusted to give optimal sensitivity at frequency f , the resulting rms shot noise there is [equation (125a) of Reference A-1]

$$h = \tilde{h}\sqrt{f} = \left[\frac{2\pi\hbar\lambda_l(1-\mathcal{R})}{I_o\eta} \frac{1}{L} f^2 \right]^{1/2} = 1.2 \times 10^{-22} \left(\frac{f}{1 \text{ kHz}} \right) \text{ for bursts.} \tag{A.24a}$$

This is the sensitivity shown on the upward sloping line in Figure A-4a. It is presumed that light resonating is used for periodic and stochastic searches, with a resultant narrow banding of the detector to $\Delta f = (1-\mathcal{R})c/(4\pi L) = 0.6 \text{ Hz}$; figure 9.13 of Reference A-1. (If squeezed light is used, the same sensitivity can be obtained with a broader bandwidth—in fact, recycling plus squeezing in principle can achieve this same sensitivity as narrow-band resonating, but with $\Delta f \sim f$; cf. section 9.5.3f of Reference [A-1].) If the optics are adjusted to put the optimal sensitivity at frequency f , then the photon shot noise is [equations (125b,c) of Reference A-1]

$$h = \left[\frac{2\hbar c\lambda_l}{I_o\eta} \times 10^{-7} \text{ Hz} \right]^{1/2} \left(\frac{1-\mathcal{R}}{L} \right) = 6 \times 10^{-29} \text{ for periodic waves,} \tag{A.24b}$$

$$\begin{aligned}
h &= \left[\frac{2\hbar c\lambda_l}{I_o\eta} f \right]^{1/2} \left[\frac{4\pi}{c} \left(\frac{1-\mathcal{R}}{L} \right)^3 \times 2 \times 10^{-7} \text{ Hz} \right]^{1/4} \\
&= 1.4 \times 10^{-25} \left(\frac{f}{1 \text{ kHz}} \right)^{1/2} \text{ for stochastic waves.}
\end{aligned} \tag{A.24c}$$

Here it is assumed that the stochastic search is restricted to the bandwidth over which the narrow-banded detector has good performance.

At frequencies below about 100 Hz these shot-noise limited sensitivities are so good that light-pressure fluctuations on the mirrors produce stochastic mirror motions that become a more serious problem than shot noise. The result, after adjustment of laser

power to produce an equal balance of light-pressure noise and shot noise, is the so-called "standard quantum limit" for the detector's sensitivity [equations (126) of Reference A-1]:

$$h = \left[\frac{2}{\pi^2} \frac{\hbar}{mL^2} \frac{1}{f} \right]^{1/2} = 1.2 \times 10^{-24} \left(\frac{1000\text{Hz}}{f} \right)^{1/2} \quad \text{for bursts,} \quad (\text{A.25a})$$

$$h = \left[\frac{2}{\pi^2} \frac{\hbar}{mL^2} \frac{10^{-7}\text{Hz}}{f^2} \right]^{1/2} \\ = 1.2 \times 10^{-29} \left(\frac{1000\text{Hz}}{f} \right) \quad \text{for periodic waves,} \quad (\text{A.25b})$$

$$h = \left(\frac{4}{3\pi} \right)^{1/2} \left(\frac{4\hbar}{mL^2} \right)^{3/8} \left[\frac{\hbar\lambda_l}{I_o\eta c} \left(\frac{2 \times 10^{-7}\text{Hz}}{f} \right)^2 \right]^{1/8} \\ = 4 \times 10^{-26} \left(\frac{1000\text{Hz}}{f} \right)^{1/4} \quad \text{for stochastic waves.} \quad (\text{A.25c})$$

Here \hbar is $\frac{1}{2}\pi$ times Planck's constant. There are known techniques, at least in principle, for circumventing this quantum limit in the periodic and stochastic cases [section 9.5.3f of Reference [A-1], but nobody yet has found a way around this limit when searching for broad-band bursts.

The Advanced Detector sensitivities of figures A.4 presume that seismic noise is strongly debilitating at frequencies $f \lesssim 10\text{Hz}$. The indicated location and form of the seismic-noise cutoff is a very crude guess. The sensitivities also assume vastly improved suspension systems so that thermal noise does not enter the noise budget.

Conclusions

By comparing the source strengths and benchmark sensitivities in figures A.4a,b,c one sees that (i) *There are nonnegligible possibilities for wave detection with the first detector in the LIGO.* (ii) *Detection is very probable at the sensitivity level of the Advanced Detector.* (iii) *The first detection is most likely to occur, not in the initial detector in the LIGO but rather in the second or third, as the sensitivity and frequency are being pushed downward from the middle curves toward the bottom curves of figures A.4a,b,c.*

REFERENCES

- A-1. Kip S. Thorne, "Gravitational Radiation", in *300 Years of Gravitation*, edited by S. W. Hawking and Werner Israel (Cambridge University Press, Cambridge, England 1987), pp. 330-458; available in preprint form from Kip S. Thorne, 130-33 Caltech, Pasadena, CA 91125.
- A-2. Joseph H. Taylor and J. M. Weisberg, *Astrophysical Journal*, **253**, 908-920 (1982).
- A-3. Douglas M. Eardley, David L. Lee, and Alan P. Lightman, *Physical Review D*, **8**, 3308 (1983); chapter 10 of Clifford M. Will, *Theory and Experiment in Gravitational Physics* (Cambridge University Press, Cambridge, 1981).
- A-4. J. E. Faller, P. L. Bender, J. L. Hall, D. Hils, and M. A. Vincent, in *Proceedings of the Colloquium "Kilometric Optical Arrays in Space"*, Cargese (Corsica), 23-25 October 1984. ESA SP-226.
- A-5. See, e.g., Section 7.2 of Yakov B. Zel'dovich and Igor D. Novikov, *Relativistic Astrophysics Vol. 2, The Structure and Evolution of the Universe* (University of Chicago Press, Chicago, 1983).
- A-6. See, e.g., K. I. Kellerman and B. Sheets, editors, *Serendipitous Discoveries in Radio Astronomy* (National Radio Astronomy Observatory, Green Bank, West Virginia, 1983).
- A-7. Richard A. Saenz and Stuart L. Shapiro, *Astrophysical Journal*, **221**, 286 (1978).
- A-8. See, e.g., T. Nakamura, in *Gravitational Collapse and Relativity*, eds. H. Sato and T. Nakamura (World Scientific, Singapore, 1987), p.295; also see the discussion and references in section 9.3.3(e) of Reference 1.
- A-9. Bernard F. Schutz, *Nature*, **323**, 310 (1986).
- A-10. J. P. A. Clark, E.P.J. van den Heuvel, and W. Sutantyo, *Astronomy and Astrophysics*, **72**, 120 (1979).
- A-11. Bernard F. Schutz, "Sources of Gravitational Radiation", in *Gravitational Wave Data Analysis*, edited by B. F. Schutz (Reidel, Dordrecht, 1988), in press.
- A-12. Roger D. Blandford, unpublished work reviewed in equation (57) of Reference 1, and associated discussion.
- A-13. S. Chandrasekhar, *Physical Review Letters*, **24**, 611 (1970); J. L. Friedman and B. F. Schutz *Astrophysical Journal*, **222**, 281 (1978).
- A-14. R. V. Wagoner, *Astrophysical Journal*, **278**, 345 (1984).
- A-15. K. S. Wood, P. F. Michelson, P. Boynton, M. R. Yearian, H. Gursky, H. Friedman, and J. Dieter, *A Proposal to NASA for an X-Ray Large Array (XLA) for the NASA Space Station* (Stanford, Palo Alto, CA, 1986).
- A-16. J. H. Taylor, in *General Relativity and Gravitation*, ed. M. A. H. MacCallum (Cambridge University Press, Cambridge, 1987).
- A-17. A. Vilenkin, in *300 Years of Gravitation*, ed. S. W. Hawking and W. Israel (Cambridge University Press, Cambridge, 1987), p. 499.
- A-18. J. R. Bond and B. J. Carr, *Monthly Notices of the Royal Astronomical Society*, **207**, 505 (1984).

APPENDIX B

LIGO CONCEPT

In this appendix we present more detailed justifications and discussions of issues raised in Part IV.

A. Essential Features of the LIGO

The design goals of optimizing the probability of discovering gravitational waves and optimizing the information extracted from the waves dictate the following essential features of the LIGO:

1. Two widely separated sites under common management.
2. Arm lengths of order 4 kilometers at each site.
3. The capability to operate simultaneously several receiver systems at each site.
4. The capability for receivers of two different arm lengths.
5. A vacuum tube diameter of order 48 inches.
6. The capability of a vacuum level of 10^{-8} torr.
7. A minimum lifetime of the facilities of 20 years.
8. Adequate support instrumentation.

Discussion of these essential features follows:

1. *Two antennas at widely separated sites.* At least two receivers located at widely separated sites are essential for unequivocal detection of gravitational wave bursts. The best means to eliminate the large set of external noise sources (seismic noise, acoustic noise, ...), as well as internal impulsive phenomena (sudden strain release in wire suspensions, fluctuations in index of refraction of residual gas, ...), is to operate the two receivers with comparable sensitivities at separations sufficiently large so that the noise at the two locations is uncorrelated over the relevant observation times. Gravity wave signals, by contrast, would be correlated.

2. *Arm lengths of order 4 kilometers.* The choice of antenna arm length is a complex tradeoff between achievable sensitivity and cost. A "first-order" version of the tradeoff is this (see below for details): In the regime where gravitational waves are most likely to be found (at $f \leq 100$ Hz and $h \leq 10^{-21}$), the dominant noise is likely to be local stochastic disturbances (seismic, acoustic, thermal, local gravity gradients). In this regime the gravity-wave event rate (number of detectable sources) scales with detector sensitivity as h^{-3} , and h scales with arm length as L^{-1} , so (event rate) $\propto L^3$. By contrast, at arm lengths $L \lesssim 1$ km fixed costs dominate, so the cost is roughly independent of L while at $L \gtrsim 4$ km cost is roughly proportional to L so a doubling of L (and cost) increases the event rate by ~ 8 .

A more careful discussion reveals the justification of and second-order caveats in this analysis: For arm lengths short compared to half the gravitational wavelength ($1/2 \times 300$ kilometers for 1 kHz waves), the signal $\Delta L = hL$ increases linearly with length, L (Equation II.1). By contrast, many, indeed most, noise sources are unaffected

by the separation L of the test masses. Holding constant all other variables except the arm length, L , the scaling of the strain amplitude noise, h (i.e. $\tilde{h}\sqrt{\Delta f}$ in notation of Part II and Appendix A), with L is:

$1/L$ for

- most stochastic disturbances (seismic, acoustic, thermal, local gravity gradients, ...), noise produced by objects at distances much less than L from the test masses;
- the quantum limit (Figure II-2; Equation A.25 of Appendix A);
- photon shot noise if the light storage time in the antenna arm is limited to much less than $1/2$ the gravitational wave period for burst sources;
- photon shot noise in a search for periodic sources with an optical resonating recycling system (Section VI.A.2(b); Equation A.24a);

$1/L^{3/4}$ for

- statistical fluctuations in the index of refraction of the residual gas for fixed pressure and minimum optical beam size;
- photon shot noise in a search for stochastic waves using optical resonating recycling (Section VI.A.2(b); Equation A.24b);

$1/L^{1/2}$ for

- photon shot noise using light recycling on burst sources with optimum storage times in the arms (Section VI.A.2(b); Equation A.24a);

Independent of L for

- photon shot noise for storage times \gtrsim half the gravitational wave period, but without recycling or resonating (Equations A.21, A.22).
- gravity gradient noise from objects at distances large compared to L .

With these differing dependencies on arm length of the various noise sources, the expected variation of interferometer sensitivity with length depends on the dominant noise source and the instrument configuration. For example, for a wideband receiver using light recycling, photon shot noise will vary as $1/L^{1/2}$ while most stochastic noise will vary as $1/L$.

A major consideration related to length of the arms is the rate of detectable burst events. Once the interferometer sensitivities have reached a level where it is possible to detect sources at the distance of the Virgo cluster of galaxies (e.g., for the supernovae, binary neutron stars, and binary black holes discussed in Part II, Appendix A, and Figures II-2 and A-4), the detectable event rate is expected to grow inversely with the cube of the amplitude sensitivity, h^{-3} . This is because the number of galaxies that can be monitored is proportional to the volume of the universe that can be observed, and the distance at which a specific kind of source can be detected is inversely proportional to the amplitude sensitivity. Under these circumstances the event rate varies as the inverse cube of the length-dependent factors listed above. For example, in the case of

sensitivities limited by $1/L$ -varying noise, a factor 2 increase in arm length L produces a factor 8 increase in event rate.

The expected sensitivity of advanced detectors, as given in Figure II-2, corresponds to an arm length of 4 kilometers. This limiting sensitivity just reaches that required to detect with high confidence the coalescence of neutron star binaries in distant galaxies. It is extremely important to build a system of sufficient length to have a high probability of successful detection, and this source is the only one for which both signal amplitude and frequency of occurrence can be predicted with considerable confidence. Because the dominant noise in the very best searches for this source's waves will almost certainly be the quantum limit and low-frequency stochastic forces (seismic and thermal), and because these scale as $1/L$, the event rate will almost certainly be $\propto L^3$, and an arm length substantially less than 4 km would move us out of the high-confidence regime for this, our only "semi-guaranteed" source.

3. *Capability for several simultaneous receiver systems at each site.* The facilities will be designed so that, even in the early stages of operation, they will support work on a developmental receiver system while another operational receiver system carries out a search for gravitational waves. A high live-time of the observatory will be achieved by restricting development to specified, simultaneous hours at both sites and by designing the facilities so that the vacuum is maintained for the operating receiver at all times.

As receiver technology matures, additional receivers will be accommodated with minimum interference to measurements in progress. These additional, simultaneous investigations will permit gravitational astronomy to become a research field like other branches of astrophysics with many independent and interesting research programs involving experimenters from a number of institutions.

4. *Receivers of different arm lengths.* The LIGO will be able to accommodate interferometers with both two and four kilometer arm lengths acting together as a single receiver system. The fact that gravity wave signals in interferometers are proportional to arm length can be exploited to aid in discriminating between gravity waves and local disturbances at one site, thereby reducing the spurious coincidence rate between the two sites. Such reduction may be essential to unequivocal identification of gravitational wave bursts. Two receiver beams sharing the same vacuum will also be very useful in diagnostic studies of local noise sources.

5. *Vacuum tube of order 48 inches in diameter.* The long vacuum tubes must be able to pass Gaussian optical beams without causing diffraction loss of the beams or being a serious source of scattered light. In particular, the tubes must be large enough so that motion of the tube walls, when driven by seismic noise or thermal-expansion-induced creep, do not add to the noise in the receivers through diffraction of the beams at the walls. This condition must be met with some margin for misalignment and settling of the tube supports.

The single Fabry-Perot interferometer planned at each site for the initial search will not require the full vacuum tube diameter. Longer range goals for the facilities, however, require that multiple investigations can be carried out simultaneously. Also, some of the single Fabry-Perot receiver designs will be using multiple beams for seismic noise

reduction (Section 6 and Appendix F) as well as full and half length interferometers for diagnostic studies. A single delay-line interferometer using light of 1 micron wavelength would require, because of its many discrete beams, a minimum diameter of 43 inches. The smallest standard tube diameter which satisfies these requirements is 48 inches.

6. *Vacuum level of 10^{-8} torr.* The vacuum system will be designed so that fluctuations in the index of refraction of the residual gas in the interferometer arms will not become a limiting noise source. Noise from such fluctuations depends on the ratio of the molecular polarizability, χ of the gas at the laser wavelength to the square root of the molecular thermal velocity, v_{th} . The major constituent (95 to 99%) of the residual gas in a clean stainless steel system is molecular hydrogen which diffuses out of the metal; fortunately, this gas has a small value of $\chi/\sqrt{v_{th}}$. The ultimate sensitivity goals require residual gas pressures of less than 2×10^{-8} torr for hydrogen and 1×10^{-9} torr for nitrogen. These pressures can ultimately be achieved through a combination of selection and preparation of materials, outgassing methods, and pumping strategy. The sensitivity of the first LIGO receiver (Figure II-2) is compatible with higher pressures, but the attainable vacuum cannot be allowed to limit ultimate sensitivities.

7. *Minimum lifetime of the facilities of 20 years.* The LIGO facilities are expected to be used with a succession of gravitational wave detectors of continually improving sensitivity as the receiver technology advances. Specialized receiver systems will be developed with enhanced sensitivities for specific frequency bands or temporal characteristics. As with other kinds of astronomical observatories, scientific productivity in large measure will be dependent on improvements in instrumentation over a period of many years as the technology advances.

The 20-year lifetime requirement is intended as a guide in design tradeoffs which exchange capital costs for operating costs. Such design decisions will be made so as to minimize total life cycle costs, while maintaining flexibility to deal with a variety of possible situations downstream (e.g., quick discovery of waves at large h 's versus a long struggle to find them at small h 's).

8. *Support instrumentation.* The LIGO facilities must be designed with instrumentation to monitor environmental disturbances (acoustic, seismic, residual gas fluctuations, electromagnetic interference, cosmic rays, etc.) for cross correlation with receiver signals.

B. Sites

Two sites are essential for the unambiguous detection of gravitational waves.

In the early phase of the search for gravitational waves it will be extremely important to have two sites in operation with overlapping sensitivities, frequency coverage, and observation times. Close coordination of development and operation of the two receivers is vital; this can be achieved only through common management of the two facilities. Site selection and development depends on considerations which are discussed in the following paragraphs.

Scientific considerations.

The LIGO configuration, including sites, will be chosen so that (i) most importantly, it comes close to optimizing the probability of successfully discovering gravitational waves; and (ii) secondarily (and to the extent of noninterference with (i)), it optimizes the information extracted from the waves. The implications of these criteria have been studied by a LIGO site selection working group formed from a subset of the Caltech and MIT scientists. The implications include the following:

Receiver alignment: If the two receivers at the two sites are "co-aligned" (coincident projections of their arms on the plane that bisects their two planes), then they are optimally sensitive to the same polarization state and the probability of wave detection is optimized. If one of the receivers, instead, is rotated 45 degrees relative to co-alignment, the two are most sensitive to orthogonal polarizations and together extract the most information from the waves. The Working Group has recommended co-alignment (and thus that the two sites be capable of co-alignment) in order to optimize discovery, and it strongly recommends that one of the two sites be capable of supporting (in a future upgrade) a second receiver rotated 45 degrees to the first, for maximal information extraction.

Distance between sites: Optimization of discovery dictates that the sites be much farther apart than the correlation lengths of the various noise sources that can affect the receivers; for this, 300 km is probably adequate. Optimal determination of source directions, via time-of-flight between sites (which is much more accurate than via antenna beam patterns), dictates a separation between sites as large as possible. However, at separations larger than ≈ 4500 km the detectors' planes disagree sufficiently to drive their beam patterns (the angular factors in equation (1)), even with co-alignment, far enough away from each other to noticeably reduce the probability of discovery. These considerations suggest a site separation in the range 2500 to 4500 km.

Direction between sites: The probability of detection is not significantly sensitive to the direction between sites; but the accuracy of position determination via time-of-flight between sites will be direction-sensitive when there is a network of detectors. Optimal directionality requires a minimum of four detectors at the corners of a tetrahedron of maximum volume; or, failing that, at least three detectors at the corners of a triangle of maximum area. The first likely sites are two in America and one to three in Europe. The shorter baselines within Europe give poorer angular resolution for most source directions than the transatlantic or trans-American baselines, but they will be able at the very least to resolve the two-fold ambiguity left by data from the three longer baselines alone. In general every operating site will contribute significantly to the final gravity-wave map of the sky. In the more distant future, sites in Japan and/or Australia are likely to come into operation, and their geographical position will make them a particularly useful component of a world network. The American sites should be chosen so as to contribute significantly to the area of an America-America-Europe triangle and the volume of a tetrahedron.

In terms of these scientific criteria for site selection, the preliminarily chosen site pair, Edwards, CA and Columbia, ME, is satisfactory.

Other Considerations. Site accessibility, availability, topography and geophysical nature, and expandability are additional variables that must be considered in the site selection process. Because not all of these can be quantified until further studies (such as detailed geophysical surveys) are completed, alternate sites are continuing to be explored.

C. Vacuum System and Architectural Facilities

In the past several years, substantial progress has been made toward defining the conceptual design of the LIGO facilities, leading to the list of essential features discussed in section A, above. Since the completion of the A. D. Little/Stone & Webster design study, a continuing examination has been made of ways to build a facility which meets the requirements with particular attention to finding the most economical and reliable method. Caltech's Jet Propulsion Laboratory has been principal consultant in this activity. The effort has resulted in iteration of the cost estimates of many elements of the LIGO facility such as the buildings, vacuum system, enclosure for the vacuum system, electric power system, laser cooling system, and civil engineering work. The estimates have been used in evolving and guiding the conceptual design of the LIGO.

Details of the vacuum system and supporting facilities will be defined during the engineering design phases. The conceptual design of the system will be completed during the coming 6 months before contracting for the Preliminary Engineering Design and Cost Definition. Some of our present, preliminary concepts for the vacuum system and architectural design are profiled here.

Key features of the vacuum system. The vacuum system, representing a major cost item, is that component of the LIGO, apart from the receivers, which requires the most careful planning and design. The function of the vacuum system is twofold:

1. to reduce refractive index fluctuations in the light paths along the 4 kilometer arms; and,
2. to reduce the stochastic forces on the test masses and mirrors in the instrumentation chambers.

It is expected that the vacuum enclosure will be made entirely of stainless steel tubing and bellows. This plan is consistent with our philosophy that the LIGO should be designed using established engineering practices familiar to contractors to minimize risk. The instrumentation chambers will be stainless steel vessels designed to allow easy access to receiver components. The chambers, gate valves, and support structures for the test masses and other receiver components will be arranged so that development work can proceed while maintaining vacuum where the gravity wave investigations are being conducted.

Architectural facilities. It is expected that the long vacuum tubes will be enclosed in a housing and insulated with an earthen berm in order to:

1. provide general protection from the weather;
2. reduce wind-driven vibrations;

3. improve thermal stability so as to avoid
 - a) daily fluctuations in outgassing,
 - b) mechanical thermal distortions of the tubing,
 - c) acoustic and mechanical noise that might be transmitted to the instrumentation chambers due to the possible stick/slip at tube supports;
4. protect the tubes from vandalism.

The instrumentation stations will be located in buildings and structures within the vacuum chambers will be seismically isolated. Acoustic and vibrational noise in excess of naturally occurring background will be minimized through appropriate construction specifications. It is not expected that the instrumentation stations will be used as general laboratory or operations buildings; these will be provided elsewhere at the sites.

Detailed requirements for power, cooling, and facility instrumentation will be defined during the engineering design phases. The data analysis system will include provisions for merging housekeeping and environmental information with the receiver data streams for correlation and veto analysis. The two sites are expected to include data links to the home institutions and to each other.

D. Science Strategy for the LIGO

The LIGO is being designed to give a high probability of detecting gravitational wave signals and thereby to open the field of gravitational wave astronomy. A less ambitious goal would be incommensurate with the costs and scientific effort being expended. It is clearly not sufficient to plan the LIGO as only an extension of the technology development and demonstration now being carried out in the prototype research.

The first goal of a science strategy for the LIGO is the unambiguous detection of gravitational wave signals at a sufficiently high signal to noise and event rate to establish gravitational astronomy as a means of studying astrophysical phenomena. This goal requires more than the observation of a few events per decade. It also demands a different style of research than has been the custom in the development phase of the prototype detectors; engineering and careful design must be applied to facilities and receivers so that they will operate for long periods trouble-free and without substantial attention.

A successful initial science strategy for the LIGO has to cope with the present uncertainty in the knowledge of the amplitude, rate and frequency spectra of the waves bathing the earth. Conventional wisdom holds that the initial sensitivities projected for the LIGO (middle stippled region of Figure II-2) will be needed, at the minimum, to discover waves, and that sensitivities near those of the "possible advanced detectors" (Figure II-2) may be required, and that the uncertainties in the source strengths are unlikely to be reduced before the LIGO is constructed. Even if we are lucky enough to have a nearby event, such as the supernova of 1987, register in improved bar or interferometric detectors, the event though a newsworthy singularity, could not become the basis for formulating a longer term scientific strategy for gravitational wave astronomy.

In order to deal with the uncertainty, the LIGO facilities and research program are designed to support both an observing and a development program concurrently. For

the observing program we have chosen early in the program to fix an initial receiver design, common to both sites of the LIGO. This will allow time for the engineering of the receivers and the receiver/facility interfaces. A common receiver is dictated by the fact that in cross-correlation measurements the overall sensitivity is effectively determined by the receiver with the poorer sensitivity. Furthermore, given the intellectual and financial resources available to the LIGO, a common receiver is the most sensible way to guarantee that two sites together will be able to carry out a meaningful observation in a timely manner.

The observing program requires the development of more than just the receivers. A facility instrumentation system is required to monitor environmental disturbances such as ground and acoustic noise, electromagnetic field fluctuations, and residual gas fluctuations. Such monitoring is needed to diagnose intermittent problems in the receivers and ultimately become part of the overall experiment design, and to veto the events in the non-Gaussian tail of the receiver noise which in turn affect the accidental coincidence rate between the sites.

The initial receivers as currently envisaged will probably be designed for broadband coverage of a wide range of frequency, from a few hundred Hertz to several kilohertz. The sensitivity will be the highest that we can reliably achieve at the time the design has to be frozen; it may be somewhere near that suggested by the "LIGO Possible Early Detector" curves in Figures A-4a,b,c. The data analysis of the cross-correlated output from these first receivers can be tailored to search for bursts, periodic sources and a stochastic background. (This present concept for the initial receiver may change if developments in the prototype research or in source expectations make some other variant of receiver preferable). The initial receivers will be designed and built by members of the LIGO project and components will be constructed in the research laboratories, in industry and by affiliates of the project at other research centers. The engineering, management and documentation of the receiver design and construction will be the responsibility of the LIGO engineering staff.

A continuing development program is needed irrespective of whether the initial observations are successful or not. In the case that no detections are made with the first receivers, it will be urgent to have prepared and begun to test new receiver designs with increased sensitivity and spectral coverage. This will be carried out in part in facilities on the Caltech and MIT campuses that are able to handle full scale receiver components, and in part within the long baseline facilities themselves. The scaling from short to long baselines is an important factor in the receiver development especially as some of the proposed methods to enhance the sensitivity in second generation receivers cannot be adequately tested on small baselines. We therefore envisage that the LIGO will be constructed in such a manner as to enable development and observation with a minimum of interference. The expectation is that smooth transitions will be possible from one observing receiver system to the next iteration of an enhanced receiver system that has been technically qualified in the LIGO.

In the event of detections in the initial observing program, the dual capability for observation and development is also important; but in this case the optimization of the enhanced receiver designs will be guided by the observed signals. The scientific

program, once detections have been made, is expected to change substantially. There will be multiple demands on the facilities as the field moves from a discovery phase to a diagnostic one. One could expect good scientific reasons to carry out continuous observations for improved statistics and comparative studies, but equally good reasons to develop specialized receivers tailored to studying specific sources, and most likely pressures to look deeper and with more sensitivity. The success of the field will doubtless engender enough interest so that a much larger part of the scientific community, both observers and instrument developers, will want to join the new science. At this point in the LIGO project it would be most useful to multiplex the facilities and enable the use of the LIGO for many different and concurrent observing programs. The necessary manpower and the resources should then be readily available.

Once waves have been detected, the gravitational sky will have to be connected to the electromagnetic one, which means that source location will become an important part of the science. A single gravitational wave receiver has such little directivity (cf. the angular factors in equation II.1), that the best means for determining source position is by measuring time of flight between several receiver sites. The initial two LIGO sites are not sufficient to uniquely specify the source position; four sites at the corners of a large-volume tetrahedron will be required to make an unambiguous identification of source positions over the whole sky. At the present point in the development of gravitational wave research, it is unrealistic for the LIGO project to propose any more than the minimum configuration of two sites to establish the field. It is possible, though not guaranteed, that European, Asian and/or Australian research groups will build large baseline gravitational wave systems and thereby will help develop the network required (cf. Section B above on Sites).

If, unexpectedly, not only does the rest of the world fail to contribute to a network of receivers on the same timescale as the LIGO but even fails to build receivers after waves are discovered, it may be appropriate for a third site to be added to the LIGO.

Once waves have been detected, the extraction of their full information will require measuring the two wave forms $h_+(t)$ and $h_\times(t)$; and the determination of the graviton spin will require a network measurement of h_+ and h_\times in two or more independent ways. For these purposes unless several receivers with proper orientations are being built elsewhere in the world, it will be important to construct at one of the LIGO sites additional arms, rotated 45 degrees to the first (see Section B above on Sites).

The optimum strategy for facility upgrades, once sources have been observed, is not easy to anticipate; it depends critically on what has been discovered.

APPENDIX C

NATIONAL AND INTERNATIONAL COOPERATION

Caltech and MIT are committed ultimately to operate the proposed LIGO as an open facility for the benefit of the U.S. science community. In addition, international collaboration will be pursued vigorously in order to enhance the LIGO's observing capabilities and science output, while reducing the cost to any one country for a full program in gravity wave astronomy. The final design and construction proposal, to be submitted for NSF approval during this proposal's grant period, will address these items in full, on the basis of serious contacts with the national and international communities.

We intend to convene in the near future a workshop for the national and international communities. At this meeting current plans and concepts for the Caltech-MIT LIGO will be presented and discussed. This will allow others to critique and influence the design activities in a timely fashion, it will provide a basis for others to perform technical tasks in affiliation with the LIGO team, and it will provide data for others to do planning for their eventual use of LIGO, once it has reached its steady state operational phase.

As discussed below, a two-site U.S. observatory under single management will provide the indispensable nucleus of a worldwide effort in gravity wave astronomy. Significant science can be done with the proposed LIGO alone. However, a full operation that maximizes science results and allows their correlation with electromagnetic data (position resolution, in particular) will ultimately require an expanded interferometer network, consisting to first order of four interferometers, ideally at the corners of a large volume tetrahedron. It is our intention to engage in serious negotiations with potential partners in this enterprise outside the U.S., particularly in Europe, where France, Germany, Great Britain, and Italy have development programs relevant to the LIGO project. We intend to seek agreements on protocols for technical compatibility of facilities, exchange of data, and operational planning, and to institute mutual exchange of technical data. We are hoping for support in these endeavors from the International Office of NSF. We believe a favorable climate for such international collaboration exists with the existing science teams. In fact, (I. Corbett, G.B., private communication) the European planning efforts are proceeding with the assumption that a two-site U.S. LIGO will exist in time to provide the European effort with the necessary long-baseline complement to its system.

The initial U.S. effort must involve two sites at the minimum, because cross-correlated measurements between two widely separated sites are mandatory for identification of gravity waves amidst a background of local, non-Gaussian noise. Since the LIGO project entails a totally new technology, a single management for the two-site core facility is essential to assure timely optimization for design tradeoffs, comparable sensitivity, operational compatibility, simultaneous availability, and scheduling.

APPENDIX D

SUMMARY OF NOVEMBER 1986 NSF REVIEW

The following is a copy of the title page and Summary from "Report to the National Science Foundation by the Panel on Interferometric Observatories for Gravitational Waves," which was submitted to NSF in January 1987 after a one-week (November 1986) review of the LIGO Project.

Report to the National Science Foundation

by the

Panel on Interferometric Observatories for Gravitational Waves

January 1987

5. SUMMARY

- A) A strong case has been made for the scientific value of the goals of the project.
- B) Though there are large uncertainties associated with the strengths of the many different kinds of astrophysical sources and the ultimate capability of interferometric detectors, there is a high probability that this facility will ultimately provide for a giant leap in our understanding of the gravitational force, one of the most fundamental forces of nature, as well as our knowledge of astrophysical phenomena.
- C) It is anticipated that this facility would uniquely provide the most sensitive and certain prospect for detecting astrophysical events and identifying their nature. Essential to this capability is the twin nature of the two interferometers. Though companion efforts in other countries are highly desirable, a common management of the two LIGO detectors is important both for the coordination of the observational program and for the analysis and identification of observed events. This facility would provide for a continued and thriving development of the field.
- D) It is important to proceed directly to the construction of a long baseline interferometer in a timely manner since many aspects of the detector development program cannot otherwise be tested.
- E) The rate of detectable extragalactic events increases as the cube of the interferometer sensitivity, thus putting a high premium on the long baseline. Though a multistage, or phased authorization to the final configuration was carefully considered, the panel does not recommend this approach. We recommend full authorization with phased construction and appropriate milestones.
- F) The plans as described in the presentations and in the various documents provided appear to be well conceived. The procedure which has been employed in drawing up the existing designs and in making the cost estimates appears reasonable and adequate for proceeding to the final design for submission. Effort should continue to examine design alternatives which may decrease costs, particularly in the area of the vacuum system and enclosure. We do not recommend that the project be delayed by this process of re-examination. It is important to make the choice between Fabry-Perot and Michelson interferometer type detectors before submission of the final design. However, it remains important to develop advanced detectors and therefore research should continue to this end.
- G) Because of the magnitude and dual nature of the facility, with laboratory sites widely separated, it is especially important that the construction and operation be well managed. The panel feels that the project requires a single scientific project leader of high stature to direct the activities. Efforts should immediately be directed to providing such leadership.
- H) In looking forward to the utilization of the facilities it should be recognized that in addition to a budget for its operation, adequate funds will be required to support both the needs of experimental groups and further detector development.

I) In conclusion, the panel enthusiastically supports this development effort and urges that the plans for the project be refined along the lines indicated and that the design be completed. We recommend, then, that the construction project be brought to the National Science Foundation Board for consideration and (hopefully) for funding.

Panel Members:

Daniel B. DeBra
Val L. Fitch
Richard L. Garwin
John L. Hall

Boyce D. McDaniel
Andrew M. Sessler
Saul A. Teukolsky
Alvin A. Tollestrup

APPENDIX E

OTHER PROGRAMS IN GRAVITY WAVE OBSERVATIONS

Several other types of gravitational wave detectors are under development [E-1]. The timing of pulsars (comparison of rotation rates of distant neutron stars with ticking rates of atomic clocks on earth) has produced cosmologically interesting limits on extremely low frequency gravitational waves ($f \sim 10^{-7}$ to 10^{-8} Hz) [E-2]. NASA's doppler tracking of spacecraft is being used to search for low-frequency waves ($f \sim 10^{-1}$ to 10^{-4} Hz) [E-3]; and feasibility studies are being carried out [E-4] for interferometric detectors, like those in the LIGO, which would fly in space and replace doppler tracking in the low-frequency band. In the high-frequency band, $f \sim 10$ Hz to 10^4 Hz, in addition to the interferometric detectors that we are developing, there are earth-based bar detectors in which the gravitational wave drives a normal mode of vibration of a solid bar of aluminum, niobium or sapphire, and an electromechanical transducer monitors that mode [E-5]. Bar detectors are discussed in Part II.D.

Interferometric detectors are under development elsewhere in the world [E-1]. In 1977 the Max Planck Institute in Munich, West Germany initiated an interferometric effort under the leadership of H. Billing, and Glasgow University initiated an effort under the leadership of R. W. P. Drever. Since Drever joined Caltech, the Glasgow effort has been led by James Hough. The Max Planck group initially developed a 3-meter delay-line prototype receiver, then after several years expanded to a 30-meter system at Garching. Glasgow University began with a short delay-line testbed, then switched to a 10-meter Fabry-Perot. The present performance of the different interferometric systems is comparable. In terms of strain sensitivity (i.e. \dot{h}), the 40-meter system has the best performance at frequencies above 500 Hz, while the Max Planck system is better at lower frequencies. In terms of displacement sensitivity, the Glasgow system is about three times better than any of the other systems at frequencies above 1 kHz.

In 1983 Alain Brillet initiated an interferometric effort in Orsay France. Since then he and his group have focussed primarily on the development of high-intensity, highly frequency-stable laser sources, an effort of considerable importance for us and the other groups. In 1985 Nabuki Kawashima initiated an interferometric effort at the Institute of Space and Aeronautical Science in Tokyo; and in 1987 a group under Adalberto Giazotto in Pisa Italy, working on antiseismic isolation, initiated a collaborative agreement with the French group for interferometric work.

There are strong interactions between the American, European, and Japanese interferometric groups, including occasional exchanges of personnel; and we expect those interactions to increase as time passes. (See the discussion of National and International Cooperation in Appendix C.) We are hopeful, but not certain, that the Europeans will construct one or two full-scale interferometric systems sufficiently rapidly to provide, with the American LIGO, a sizable fraction of the world-wide network which is required for extraction of full information from the waves. On a longer timescale, we hope for a Japanese or Australian completion of the network. (Cf. the discussion of sites in Appendix B.)

REFERENCES

- E-1. For a general review, see e.g., Kip S. Thorne, "Gravitational Radiation", in *300 Years of Gravitation*, edited by S. W. Hawking and Werner Israel (Cambridge University Press, Cambridge, England), pp. 330-458; available in preprint form from Kip S. Thorne, 130-33 Caltech, Pasadena, CA 91125.
- E-2. Joseph H. Taylor, in *Proceedings of the Eleventh International Conference on General Relativity and Gravitation*. (Cambridge University Press, Cambridge, 1987).
- E-3. Frank B. Estabrook, *Acta Astronautica*, in press.
- E-4. J. E. Faller, P. L. Bender, J. L. Hall, D. Hils, and M. A. Vincent, in *Proceedings of the Colloquium "Kilometric Optical Arrays in Space"*, Cargese (Corsica), 23-25 October 1984. ESA SP-226.
- E-5. P. F. Michelson, J. C. Price, and R. C. Taber, *Science*, **237**, pp. 150-157, 10 July 1987.

APPENDIX F

PRELIMINARY DESIGN OF A LIGO FABRY-PEROT RECEIVER

F.1 Introduction

In Section V-A.1 of this proposal an outline is given of some of the basic ideas of a Fabry-Perot gravity-wave detector and of the status of the current experimental work. The experimental development of succeeding variants of this instrument over the 8 years since the idea was conceived has given a strong background of practical experience, and it is now a sophisticated piece of apparatus. We have now reached a stage where it is possible to design in considerable detail a Fabry-Perot detector based on our present knowledge which could be operated in the LIGO facilities with a good probability of satisfactory operation, and likely to reach at least the initial sensitivity estimates indicated in Figures A-4a,b,c. An outline of such a design is summarized here, both to give some indication of the kind of instrument we are developing, and also to give a better idea of the technology involved. It should be emphasized that this particular design was intended as an initial receiver to be built at minimum risk with our existing technology, and not the design we would be capable of producing some years from now—when we would have to freeze the design—nor as a design for the highest performance we could currently aim at. It is an essentially simpler design than some in our longer-term plans.

F.2 Goals of the Design

(A) A reasonable compromise between maximum designed sensitivity and avoidance of risk of failure due to excessive dependence on untested technologies.

(B) Design of a relatively simple "Base Model" intended to easily achieve a satisfactory and potentially useful performance for initial operation, but designed also for future enhancements by addition of further components, increasing laser power, etc., to form a variety of compatible future "Upgrades" from which a planned succession of receivers can be chosen. In addition, the possibility of some "Downgrades" from the Base Model is also taken into account, in case development becomes delayed, unexpected problems arise, or cost restrictions force cutbacks in initial performance.

(C) A receiver design which is as compatible as possible with other receivers which may share the vacuum system and operate concurrently. The objective of using or obscuring a minimum area of the cross section of the vacuum pipe has thus been an important factor in the design, so that the maximum number of other receivers, which may have test masses located either behind or in front of its own test masses, may be operated with it. Design choices giving minimum cross sectional area have been adopted wherever possible.

(D) A basic receiver design capable of being realized and enhanced in a way which is economical both in construction cost and in design effort. To this end the construction of the receiver is made modular as far as possible, with most elements common throughout the different versions and upgrades or downgrades. This should allow economies in design effort, and facilitate small-scale quantity production of the main units so that cost

and effort required eventually to put into operation several receivers covering different gravitational wave experiments will be minimized. Also common components are used as far as possible for various functions within any one interferometer, so that items such as test mass blanks and many suspension components can be ordered in quantity.

(E) A receiver system capable of operation over extended periods without manual adjustment. A totally automatic alignment control system is an important feature of the design, as it is felt that this will become an essential operating requirement with any type of interferometer having kilometer-long lever arms in the optical beams. A manual alignment system is however also provided for early test purposes, and as a backup which comes automatically into operation in case of disruption by excessive seismic noise, loss of servo lock, equipment malfunction, or other types of failure.

(F) A general aim is to maximize the probability that the receiver when built will actually operate as planned, and in particular to design an interferometer which will be as immune as practicable to unpredicted phenomena which might reduce sensitivity. To this end the interferometer is designed to hold as constant as possible parameters which otherwise might conceivably introduce noise at frequencies near the gravity wave frequency region. Parameters which are controlled and maintained constant at relevant frequencies in this design include laser beam frequency, intensity, diameter, divergence and spectral composition; beam direction and position parameters in each arm relative to the positions of the test masses; and test mass translational and rotational coordinates. (Differential forces required to maintain the relative distances between the pairs of test masses in each arm constant are recorded as a measure of the gravitational wave.) Precautions taken in the design to control some of the parameters do go further than experience so far with prototype interferometers has shown to be absolutely essential, and it is quite likely that it may later be found to be unnecessary to control all of them as well as is provided for. However building in this control gives additional insurance against quite large classes of unpredicted phenomena.

F.3 Summary of Characteristics of the Base Model Receiver, and Planned Upgrades and Downgrades

Consideration of the goals listed above has led to a design in which initial operation of the basic interferometer is planned with light from a single argon laser, though possibly with additional argon lasers available as backup. This approach requires minimal extension over present prototype operation. Recycling (Section V-A.2b) is proposed as a means of achieving good sensitivity with this relatively low power input, as it is judged that operation in a recycling mode will be easier and have less risk of failure than adding lasers together or use of Nd:YAG lasers. (If Nd:YAG lasers were used it may be advantageous to employ frequency doubling to keep within the wavelength region that allows use of the relatively small low-loss cavity mirrors and test masses proposed here.)

Two versions of the Base Model are contemplated: Version 1, currently proposed as the first interferometer, intended for broadband searches; and Version 2, envisaged as likely to be later unless there is some unexpected development in source estimates or detector technology, optimized for narrowband operation. The proposed main characteristics of these and of their upgrades and downgrades follow.

(A) Base Model, Version 1 (Broadband)

- (1) Light source—one single-mode argon ion laser, giving 5 to 6 watts output at 514 nm. (e.g. Coherent Innova or Spectra-Physics large-frame lasers of nominal all-line power 20 watts).
- (2) Test Masses: Fused Silica, 8 inches diameter by 5 inches long, with ultra-low-loss mirror coating over the front surface giving a minimum usable area 5.5 inches in diameter.
- (3) Test mass suspension giving primarily passive seismic isolation, but with a slaved active antiseismic system using an auxiliary interferometer to make seismic motions of the suspension points at opposite ends of each arm track one another.
- (4) Wideband optical recycling is employed to increase effective light power.
- (5) Broadband operation is envisaged, with useful sensitivity over the range from below 100 Hz to above 5 kHz.

(B) Base Model, Version 2 (Narrowband)

Almost all main components are identical to those of Version 1, but some of the internal optics are modified to give optical resonating (Section V-A.2b) for optimized narrowband searches.

(C) Upgrade 1

Either version as above, or with Upgrades 2 or 4, but with light power increased to 20 watts by use of four argon lasers with their outputs added together coherently. This would be expected to improve sensitivity by a factor of 2 at the higher frequencies.

(D) Upgrade 2

Addition of active antiseismic guard system along three axes of the test masses near the junction of the arms, and along the transverse and vertical axes of the test masses at the remote ends of the arms. This can be applied to any of the versions or upgrades.

(E) Upgrade 3

Replacement of the argon laser light source by a Nd:YAG laser system with frequency doubler giving 100 watts of stabilized green light. This would be expected to improve sensitivity over that of Upgrade 1 by a factor slightly more than 2 in the high frequency region, and reduce electric power consumed.

(F) Upgrade 4

Increase the size of the test masses to 1 ton by bonding the smaller test masses with their low-loss mirror coatings to the front of larger fused silica masses, using optical contacting. This is a modification which may extend low frequency performance at some possible penalty in high frequency performance, so is more likely to be used as another concurrently-operating receiver than as a change to the Base Model.

(G) Upgrade 5

Use of squeezed-light techniques (Section V-A.2b). A probably late addition to improve performance of the broad-band model receivers.

Two possible Downgrades have been considered:

(H) Downgrade 1

The Base Model, Version 1, without recycling.

(I) Downgrade 2

The Base Model without the slaved active antiseismic system.

F.4 Specific Aspects of the Receiver Design

This complete receiver design is an integrated whole, with the optical interferometer section, the laser light source, a beam conditioning system, and the test mass suspension with servos for controlling test mass position and orientation, tightly integrated together and most of them influencing one another. The design in fact encompasses a family of variants of the basic system but some idea of the general philosophy may be gained from just two diagrams, Figure F-1 (placed following page F-10 for convenient reference while reading the explanation) which shows the main optical layout and some of the interferometer servos, and Figure F-2 (on page F-12) which indicates schematically how the suspensions and the positions of each of the four test masses are controlled.

To clarify the operation of the system, the diagrams are simplified to a considerable extent, and details such as lenses, amplifiers etc. are omitted.

(A) Main Interferometer (Base Model)

The main interferometer is based largely on the present 40-meter prototype and on experience obtained with this instrument. By designing the Base Model system for operation by a single argon ion laser, giving an input of only about 6 watts, it has been possible to make the design a very conservative one, with no components transmitting unusually high powers, and no requirement for any Pockels cell or other electro-optic or acousto-optic modulators any larger than those already used in the prototype. Indeed no components are exceptionally large, and even the main Fabry-Perot mirrors (8 inches in outside diameter, with a 5.5 inches diameter working area) do not require a figure accuracy any better than that of normal good optical components—as will be discussed later. In spite of the low input power and low power rating required of active components, high sensitivity is achieved by a recycling technique.

This receiver design includes several new features and concepts, not previously described, so we outline the operation of the system in stages in spite of the interconnections. It is simplest to begin with the basic interferometer, shown on the right hand side of Figure F-1 (following page F-10), and proceed gradually backwards through the system to the lasers on the left.

(1) Interferometer

The two main interferometer cavities, spanning the 4 km arms of the system, are shown at the extreme right-hand side and top of the Figure, labelled C2 and C1, respectively. The main beamsplitter, made with a heavy fused-quartz substrate suspended like the test masses and rotated by 45 degrees, is apparent between the cavities, along with

a matched compensating plate of fused quartz suspended parallel to it in the beam to the upper cavity.

Light enters and leaves the interferometer through two rather large additional cavities, C0 to the left of the beam splitter in the diagram and C3 below it. Both are formed by low-loss mirrors on heavy fused-quartz substrates, almost identical to the main test masses and suspended in the same way, and each cavity is about 10 meters long. The cavity C0 acts partly as a mode-cleaning cavity, and also performs other important functions in the system, while the cavity C3 is an output filter protecting the main output photodiode D1 from possible sources of spurious light such as scattered light from the walls of the 4 km beam pipes.

The central interferometer has some special features. The beamsplitter is made with a wedge angle of about 5 degrees, and its back surface has an antireflection coating designed to reflect 1% of the light from that surface, to a Pockels cell P1, which provides the main internal phase modulation for the interferometer. A mirror M returns light back to the system through the Pockels cell. The placing of the main modulator in a side arm of the system in this way has important advantages: it keeps the cell out of the high-power beam, reducing losses and possible radiation damage in a recycling system, and it makes it practical to add a small telescopic lens system (not shown) to reduce the beam size in the Pockels cell crystal from the diameter of 2 inches used for the 4 km beams to around 3 millimeters so that the small Pockels cell currently used in our prototype interferometers will be large enough. Thus the use of special high-power or large-size components is avoided.

If we omit recycling at this point for clarity, the primary locking system for this basic interferometer involves two separate frequency-locking conditions: the cavity C1 is made to resonate with the light from the laser source and the cavities C2 and C1 are brought into precise resonance with one another. The locking technique used here (and in many other places in the system) is our now-standard radiofrequency reflection locking method [F-1]. Frequency modulation at 12 MHz by the Pockels cell P1 is used for both functions. The locking into resonance of cavity C1 is done by coherently demodulating the signal from auxiliary photodiode D2 and using this to move appropriately the suspension point of the end test mass of this cavity by a coil-magnet system. (At this point the laser light is already well stabilized in frequency by a separate long-term-stable reference cavity, assisted at high frequencies by some feedback from the high-frequency-stable mode cleaner cavity, so a narrow bandwidth low-power feedback loop is adequate.) The main locking of cavities C1 and C2 together is done with much wider bandwidth and precision, using the full light power in the system, with diode D1. (In practice, with the system shown, an auxiliary narrow-bandwidth servo system is used to maintain the correct position for mirror M. This servo has been omitted for clarity, but it utilizes low-frequency (about 10 Hz) dithering of the mirror position to optimize the 12 MHz modulation amplitude, a technique used elsewhere in the receiver when a low bandwidth servo is sufficient to maintain just the steady position of a component.)

This outline covers in a basic way the primary locking of the main interferometer, but in the actual full system some further locking or stabilizing conditions have to be achieved. In particular it is necessary to ensure that the distance between the input

mirrors on the cavities C1 and C2 and the beamsplitter are kept such that a maximally dark fringe is obtained at photodiode D1 when both these cavities are in resonance, and also that the auxiliary cavities C0 and C3 are kept in resonance. There are several ways of achieving the first condition. One of these, as suggested in Figure VI-1 involves maintaining both main cavities in resonance independently of holding a dark fringe at photodiode D1; and here this may be done by locking cavity C1 as monitored by light reflected from the compensating plate, by adjustment of the position of its input mirror. The mode cleaner cavity C0, is locked to the input laser beam by phase modulating the input light to that cavity at 12 MHz, and using reflection locking with diode D6. Locking of C3 is done in the same way, using 30 MHz phase modulation applied to the input light after the cavity C0. In this interferometer design, it is planned to control the alignment of the mirrors in all of the optical cavities by the wavefront-phase type of automatic alignment system developed on the 40-m prototype, outlined in Section VI.A.1(d). In this diagram the complete automatic alignment system for one cavity, including quadrant diodes and lenses and associated electronics, is indicated by the square symbol containing the letters AA. Thus cavity C2 is kept in alignment by the Auto-Alignment unit directly below it, C1 by the unit to its left, etc.

(a) Recycling Control

The description above does not take recycling into account, but this is a relatively straightforward addition [F-2]. A special mirror assembly, labelled R, is used for recycling. Pockels cell P2 is used to apply an additional 14 MHz phase modulation to the main beam, which is then picked out by the photodiode D4 and used to lock the recycling mirror in the position for optimum operation. To avoid any loss in amplitude of the 30 MHz phase modulation in the recycling mode the free spectral range of the internal cavity formed between the recycling mirror and the input mirrors for cavities C1 and C2 is made to be a multiple of the 30 MHz modulation frequency, so that there is buildup of the sidebands as well as of the primary beam.

Acquisition of recycling condition is aided by use of a variable reflectivity mirror for R. One way of doing this is to have two close mirrors, separated by piezo transducers, so that the small cavity between them can be easily brought into resonance or out of resonance, thus changing transmission of the pair, and altering effective reflectivity. (Other ways of achieving this aim are possible, including use of frustrated internal reflection, tested earlier, or a commercial variable polarization beamsplitting unit.)

(b) A Technique for Compensating Errors in Mirror Figure and other Sources of Wavefront Distortion in a Recycling Interferometer

A technique is proposed here for much reducing demands on the figure accuracy of the super-polished mirrors which had earlier been thought necessary for good recycling. We propose the mirrors are made with only normal accuracy (of order one tenth wave). Then the compensator plate is manually hand figured while set up in an interferometer test rig using the actual components made for the real system, so that the hand-figured plate can correct for the sum of the errors in all the other parts. This is significantly easier since the compensating plate has no need for super polish, and only one surface has to be worked on for the whole system. It may be noted also that as the compensating

plate (of refractive index n) operates in transmission rather than as a mirror defining the wavefront of a nearly-Gaussian beam the effect on the optical path of a given dimensional error is reduced by a factor of approximately $n/(n - 1)$ for normal incidence, which is nearly 3 for fused quartz, and by an even larger factor at Brewster's angle. Thus the compensating plate has much less critical demands on figure accuracy than the surfaces of the cavity mirrors. The whole approach looks a very practical one. We have been told by a manufacturer of large high-precision optics who is involved in work on our prototype 40-m test masses that the required accuracy is normal practice with hand figuring, and over larger areas than ours. (It is expected that static wavefront correction will be entirely adequate, but if necessary a small additional dynamic phase correction can be applied by other techniques.)

Having now outlined the basic interferometer, we proceed to the functions and operation of the input mode cleaner C0.

(B) Beam Conditioning System

Light from the laser source enters the interferometer from the left, near the upper center of the figure, by a path labelled "from laser". The system begins with a rather large mode cleaning cavity C0, formed by concave low-loss high-reflectivity mirrors made on separate heavy fused-quartz substrates almost identical to the main test masses of the detector, and suspended and seismically isolated in vacuum in a similar but simplified way.

This cavity plays an important role in achieving high sensitivity in the interferometer, for it can define the direction of the primary laser beam with extremely high stability in the gravity-wave frequency range (50 Hz to 5 kHz). Our target here is transverse beam position fluctuations at 4 km distance of order 1 micron over this frequency range. Achievement of this stability is not in any way essential, but it is expected to be fairly easily reached by using suspension and damping techniques for the mode cleaner mirrors similar to those used for the main test masses, and this will make the interferometer relatively insensitive to small-scale surface figure errors and certain scattering phenomena in the main mirrors.

The mode cleaner mirrors are from 5 to 10 meters apart, and weigh about 8 kg. At this separation the spot size on the mirrors is large enough to make mirror distortion due to heating insignificant at the planned input power levels. The optical bandwidth of a cavity of this size made with mirrors similar to those in the 40-m prototype can be made 5 kHz or lower without significant attenuation, and this enables the cavity to fulfill another important function: additional filtering of the input beam against fast frequency, phase and intensity fluctuations. Experience with the 40-m prototype has shown that high-frequency noise in the laser can produce troublesome intermodulation phenomena in the photodiode or electronic systems, and a mode cleaner can filter out several types of spurious effects occurring in the lasers of the gravity-wave detector.

In this receiver design the beam arrives at the mode cleaner from the laser system already well frequency stabilized to a separate highly-stable reference cavity at frequencies up to at least 5 kHz. The mode cleaner has its length controlled by a magnetic force-feedback system to lock it into resonance with the laser beam, using our standard

radiofrequency reflection-locking technique. Phase modulation is applied to the input beam at 12 MHz, by a Pockels cell (labelled PC) in front of the cavity; and the reflected light, separated from the main beam by a quarter-wave plate and a polarizing beamsplitter, is detected by photodiode D6.

This mode cleaning cavity, with its well-isolated and heavy mirrors, can provide an extremely quiet final frequency reference for the laser beam, at all but low frequencies. In this design it is used as a second stage of laser frequency stabilization, by feedback of high-frequency components in the error signal to an additional phase-adjusting Pockels cell in the input beam.

The beam continues via a further phase-modulating Pockels cell, polarizing beamsplitter, and Faraday rotator (FR) to the main interferometer.

(C) Beam Generating and Control System

(1) Base Model—Single Laser Source

The Base Model receiver uses as its light source a single argon laser in a two-stage frequency stabilization system, with primary stabilization to a special high-mechanical-Q reference cavity, and a secondary trim for fast frequency fluctuations controlled by the mode cleaning cavity of the interferometer. Figure F-1 shows two lasers to indicate the overall concept. In the single-laser Base Model the laser would be arranged as shown by the laser at the extreme left-hand side of the Figure—labelled as Laser 1—and the laser shown to the right of this would be omitted.

The laser frequency is controlled by fast, small-range, and slow, large-range, piezo-driven mirrors at opposite ends of the laser cavity, aided by a wide-bandwidth trim of output light phase by a series Pockels cell [F-3]. Thus the laser cavity is kept free of electro-optical components which might limit available power or be affected by U.V. radiation damage. The laser beam passes via an isolating Faraday rotator (FR), the phase-trimming Pockels cell, an electro-optical amplitude modulator, and a radio-frequency phase modulating Pockels cell to the high-Q reference cavity C4. This reference cavity is constructed from a drilled bar of fused quartz, with end mirrors optically contacted to the ends, and is suspended in vacuum by wires from seismically isolated supports using techniques similar to those developed for suspending the bars of room-temperature resonant bar gravity-wave detectors. This gives very low mechanical and thermal noise. An automatic alignment unit (AA) aligns the laser beam to this quiet cavity by servo-driven mirrors, thus providing a first stage of active beam direction stabilization and beam wiggle reduction. An intensity monitor photodiode D9 controls the amplitude modulator, to stabilize output intensity. The stabilized output beam then passes via a second phase-trimming Pockels cell (near the center of the Figure) and a second pair of direction-controlling and position-controlling servo mirrors to the mode-cleaning cavity C0 of the main interferometer. This second phase-trimming Pockels cell receives control signals covering frequencies from about 20 Hz upwards from the mode-cleaning cavity, to give a second wide-band high-gain frequency stabilization loop based on the even quieter high-frequency reference given by the heavy isolated masses and mirrors of the mode cleaner. The complete two-stage frequency and direction stabilization system is designed to give a final beam suitable for the main interferometer without requiring any

frequency control from the 4-kilometer arms, thus avoiding any possible complications from kilometer propagation delays or the small free spectral range of the 4-kilometer cavities.

In the diagram each set of servo-driven mirrors used for controlling beam direction and position are indicated as a pair of mirrors. In fact separate fast small-range mirrors and slower wide-range mirrors are employed, to give a good combination of dynamic range and speed of response, and using four mirrors per set. Further stabilization of beam direction and position extending to the highest frequencies is provided passively by the mode cleaner C0. The dimensions of the mode cleaner cavity are determined in part by possible thermal effects in the mirrors at high intensities, and as well as by considerations of directional stability. For the power level of the Base Model receiver a cavity 0.5 meter long could be adequate, but for the higher power levels of the proposed receiver upgrades a cavity of length of about ten meters is envisaged; and as this will also give better directional stability this size is chosen for the Base Model design.

The schematic diagrams given show only one of a large number of possible design variants, and are intended to illustrate more the general approach than the final details. In this laser stabilization system, for example, it may prove useful to supplement the Pockels cell phase shifter shown in the first loop by an acousto-optic frequency shifter; or it may be useful to feed back a trimming signal from the second stage stabilizing loop to the first one. Current work with prototype interferometers is giving practical experience of these and other variants of the basic stabilization system. The arrangement shown in the figures is a fairly straightforward one, and a reasonable choice for the present design.

(2) Upgrade 1—Coherently-Added Multiple Laser Source

To upgrade the receiver it is proposed that light power be increased by adding coherently the outputs from several lasers, and use of four lasers is envisaged as Upgrade 1. The light frequency is determined by a single primary laser, and additional "booster" lasers are phase locked to the output of the primary laser and added coherently to it.

The primary laser system is identical to the Base Model laser system described above, and this defines the initial frequency and directional characteristics of the output beam. Each booster laser has its frequency, phase, and beam direction slaved to that of the primary laser, as is shown for one typical secondary laser (labelled laser 2,3,4), to the right of the initial laser 1, in Figure F-1. The beam from this secondary laser, after intensity and directional stabilization, passes to a beamsplitter which adds its output coherently to the output beam from the previous laser (or lasers) to contribute to the total output directed towards the interferometer. By monitoring the output from the other side of this combining beamsplitter with photodiode D6, a signal is obtained which is used to stabilize and phase lock the secondary laser to the output of the first. For efficient operation of this combining system the reflectivity of the combining beamsplitter has to have a specific value which minimizes the light rejected downward. The simple beamsplitter shown in the diagram is only to indicate the principle; in practice an adjustable beamsplitting system is used, and in fact an automatic self optimizing combining system has been designed to cope with changing laser outputs.

In the complete system, with one primary laser and three secondary ones, the secondary lasers use different modulation frequencies to avoid possible interaction, and the combining beamsplitters for each have different reflectivities unless adjusted automatically. The optical configurations for the three secondary lasers are otherwise identical.

Reliable coherent addition of a number of argon lasers requires that the single mode etalons used in each laser to select the operating longitudinal mode must be adjusted to select modes close in frequency to one another—at least to within about one free spectral range. Commercial lasers are designed so that the etalon is sufficiently stable for initial manual adjustment to be adequate, and this may be adequate for this system also. However the receiver design has provision for an auxiliary control system for controlling the resonant frequency of the single mode etalon in each laser.

The multiple laser source system outlined here can be extended to larger numbers of argon lasers. At a certain point it will probably become economical to switch to a more efficient type of laser system, such as a Nd:YAG laser with frequency doubler. For high power levels the system can consist of a low power laser oscillator, followed by a laser amplifier and a frequency doubler, and in this case a stabilization system similar in principle to that for the Base Model may be suitable for controlling the oscillator stage. The wavelength of the light from a doubled Nd:YAG system (530 nm) is sufficiently close to the wavelength of the green line from the argon lasers used in the design here (514 nm) that this switch of laser type can be made with minimal changes to the rest of the receiver system, when suitable laser systems become available. In this design this switch is suggested as Upgrade 3. The basic design outlined here seems capable of extension to much higher power levels than proposed for initial use, with corresponding long-term advances in ultimate performance.

(D) Test Mass Control and Isolation System

(1) Base and Upgraded Models

The primary isolation for the Base Model design is passive, and the main mass suspension inside the vacuum enclosure is in essence identical to that already well established in the 40-meter prototype. Experimental studies with the prototype system have indicated that at the proposed interferometer sites it will almost certainly give by itself more than adequate isolation against direct seismic noise at all frequencies above about 100 Hz. A major part of the isolation here is given by five-layer lead and rubber stacks, and the only changes are to improve high-vacuum compatibility by encapsulating the individual rubber pads in very compliant sealed metal bellows and by replacing the layers of lead by layers of stainless steel. As in the present 40-meter system, the design has provision for air suspensions outside the vacuum system to assist in low frequency isolation.

Arrangements for damping the seismic pendulum motions of the test masses in the Base Model are essentially similar to those already used in the 40-meter prototype or currently being installed there. To improve low frequency isolation auxiliary interferometers, as currently being installed in the prototype, are arranged to monitor differential motions of the mass suspension points along each arm. These operate servo systems

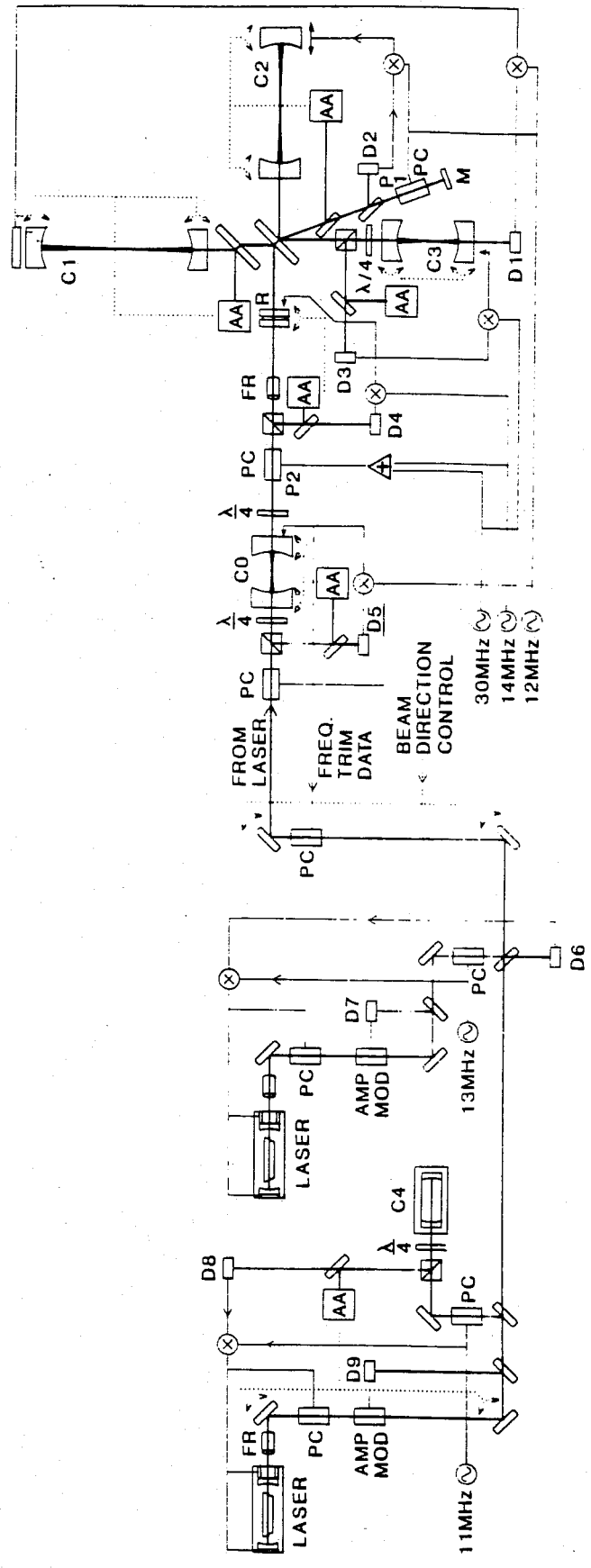

LASER 1

LASER 2, 3, 4

Figure F-1 Schematic diagram of a Fabry-Perot receiver for the LIGO

designed to make the suspension points at the stations distant from the central station track motions of the central ones.

In the Base Model version the four test masses have certain of their pendulum degrees of freedom damped to their local mounting baseplates (on the isolation stacks), using LED/photodiode shadow sensors to monitor relative motion, with piezoelectric feedback to the suspension blocks for motions in the direction of the arm—as in the prototype. Some additional vertical compliance in the suspension will be introduced by incorporating a spring in the wire supporting each suspension block, and vertical and horizontal motions of the mass transverse to the beam direction are also monitored, and horizontal and vertical damping provided by magnetic feedback to the block.

In the Upgraded Model the shadow sensors are replaced by active guard feedback systems, which cause the suspension points to track the test masses below them. This active isolation is applied to different sets of axes for the master and slave test masses. The arrangement is shown in Figure F-2, with the full feedback shown for only one of the two arms, for clarity. Both arms are similar. (It may be noted that the horizontal isolation system used here uses reference arms, as developed in early work at Glasgow [F-4], and the vertical feedback system used is equivalent to the “super spring” system developed at JILA [F-5].

An important feature of the design is that the four test mass suspensions are not operated as independent units. One test mass is regarded as the “master” mass—(labelled A in Figure F-2)—and this is taken to define an effective inertial frame for the whole system, for motions in the directions of the main beams. The suspension points for the other masses are slaved to this master one using signals provided by the main and seismic suspension point interferometers, aided at low frequencies by additional beam position monitors (not shown). Relevant degrees of freedom of each test mass suspension are controlled as follows:

Mass A. The Master mass. Free for translational motion in longitudinal, horizontal, and vertical directions—aided in the Upgraded model by the active guard system or in the Base model controlled at low frequencies by damping to local ground. (Rotational degrees of freedom for this and the other masses are separately controlled by the automatic alignment system outlined earlier.)

Mass B. A Slave mass. Longitudinal motion of the suspension block forced to track motion of the suspension block for mass A, using the seismic monitor interferometer. Transverse motions of the mass in horizontal and vertical directions made free by active guard system (Upgraded model) or damped at low frequencies to local ground (Base model).

Mass C. The “Secondary Master” mass. Similar to mass A, but very-low-frequency components (0 to 1 Hz approximately) of vertical and transverse mass position forced to track position of main interferometer beam, using signals from additional monitors.

Mass D. A Slave mass. Control of suspension block similar to that of slave mass B, with longitudinal position slaved to mass C by the seismic monitor interferometer. However there is an additional high-precision wide-band control of the longitudinal position of the mass to make the main interferometer arms very closely equal (plus

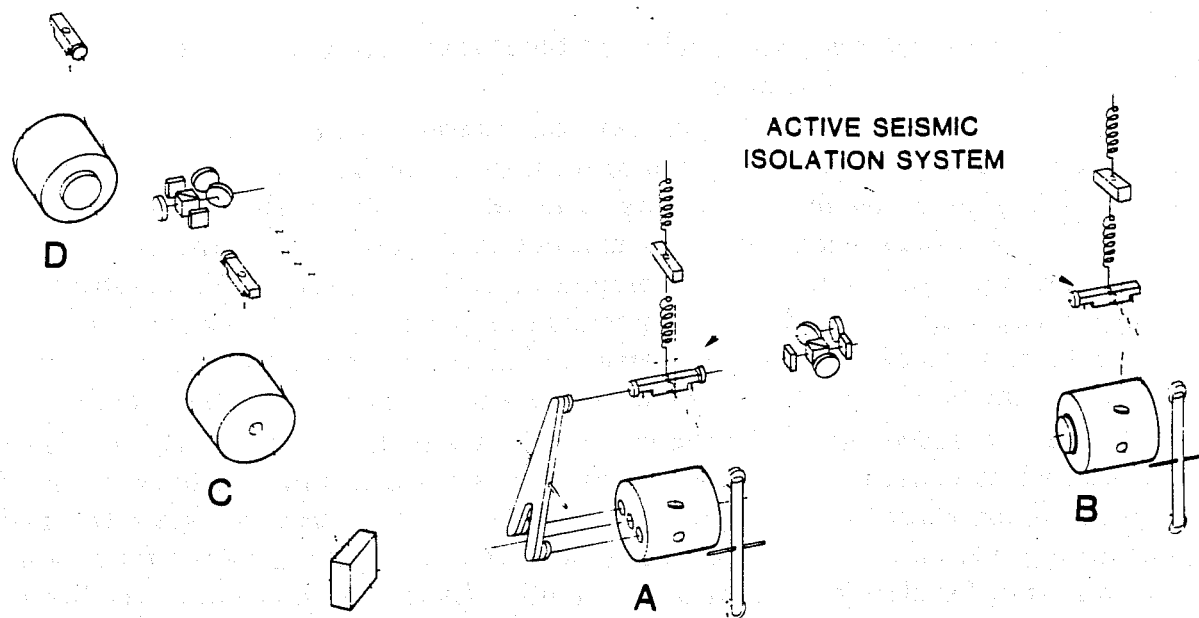

Figure F-2 Simplified sketch of arrangement of test mass suspensions in Upgrade 2 of a Fabry-Perot receiver for the LIGO, showing an active antiseismic guard system for test masses A and B added to the slaved antiseismic system of the Base Model. The suspension block of the Master test mass A is driven to track longitudinal and transverse motions of the mass using auxiliary interferometers monitoring distances to upper and lower ends of freely pivoted reference arms which remain stationary. The upper support piece, from which the main suspension block hangs by a spring, is driven to track vertical motions of the test mass, using vertical monitoring laser beams. Control of transverse and vertical motions of the effective suspension points of slave mass B is similar, but its longitudinal position is driven to track that of master mass A by the seismic monitor interferometer. The guard system for test masses C and D are similar to those for A and B, respectively, but for simplicity are not shown here.

or minus an integral number of half-wavelengths) by direct electrostatic force applied to the mass itself from a capacitor plate on a separately suspended recoil mass, using signals from the main interferometer.

(a) Note on the frequency stability of the seismic monitor laser source

The seismic monitoring suspension point interferometer on the 40-meter prototype (Figure VI-10) uses a normal helium neon laser stabilized by thermal and piezoelectric feedback to a length of optical fiber. This simple system was chosen for convenience, and could be used in the large system with some additional feedback from one of the arms: as the two arms use the same light source, frequency fluctuations cancel. However in the 4 km design, a by-product from the main interferometer system is a very highly stabilized laser source (stable to about a part in 10^{14} in the relevant low frequency region). In this design, a few milliwatts of this laser output is used for the seismic monitor, with its frequency shifted by 40 MHz in an acousto-optic modulator to avoid any danger that scattered light could affect the main interferometer system.

(b) Additional details of the seismic monitor system

The present 40-meter prototype uses a single-bounce unequal-arm Michelson interferometer for the seismic suspension point monitor of a single arm. Higher performance with low light consumption can be achieved with Fabry-Perot cavities in each arm. To keep the size and weight of the mirrors attached to the suspension blocks small, the present design (like the 40-meter prototype) uses lenses in a cats-eye retroreflector system with the lenses supported independently of the suspension blocks, in this case from the isolated baseplates.

(E) Automatic Beam Alignment and Control System

The units marked AA in Figure F-1 are automatic alignment systems which match wavefront phase, similar to the original prototype unit at Caltech. The action of this unit is effectively an extension of our old laser phase-locking technique to the spatial domain, and it uses the same basic radio-frequency techniques, mostly here with the same 12 MHz modulation frequency as the cavity and laser locking systems. A pair of quadrant photodiodes arranged to sample cross-sections of the reflected beam from a cavity at different distances along the beam sense transverse gradients of phase difference between the stored light from within the cavity and the input light reflected from the input cavity mirror, and generate control signals which tend to drive these phase difference gradients to zero. Like the phase-locking technique, this system uses light efficiently, has good signal to noise ratio, and can have wide bandwidth—up to about 1 MHz.

In the complete system, additional monitors of beam position are required, but these are omitted from the diagram for clarity.

To follow the operation of the complete aligning system it should be realized that the AA units can be made either to lock a laser beam along the correct common optic axis of a pair of fixed cavity mirrors (even though this axis may not pass through the center of either mirror), or to lock a pair of cavity mirrors into correct orientation with a fixed laser beam—in each case with wide bandwidth.

In the complete interferometer design, the master mass A and the slave mass B define the main optical alignment of the whole system. The main resonant beam in cavity C2 is arranged to pass through the centers of the mirrors on the test masses A and B by adjustment of the axis of the mode cleaner, either manually or by an auxiliary slow control system (not shown). The AA unit directly below cavity C2 in the diagram sets the orientation of the masses accordingly. Thus these two nearly inertial test masses determine the alignment and transverse location of the whole beam, running right from the center of the Figure. In the second arm of the interferometer, one end of the input beam is forced to meet the now-fixed primary beam (at the beamsplitter), and the other end of the beam is defined by the position of the center of the mirror on test mass D, to which it is directed by adjustment of the orientation of the beamsplitter. Again, this adjustment may be done either manually or by an auxiliary slow control system.

Similar actions are repeated throughout the interferometer. Some parts of the automatic control system in this design perform several of the functions previously done by optical fiber in prototypes, in allowing some independence and even relative motion between the positions of the laser system and the interferometer, and providing

some (slow) beam-dewiggling action. However this system proposed here ensures that correct alignment is maintained entirely automatically, and it can handle much higher powers than a fiber system with presently-available fibers.

Finally, the filtering cavity for the output photodiode is aligned by its own AA unit.

A system of the type proposed here should be much more user-friendly than any of the prototype gravity-wave interferometers, and capable of both reaching much more precise alignment than a manual system, and maintaining it for long periods. A manual alignment system is still required for initial start up, and in this design we propose use of a computer-controlled switching system to keep the manual system monitoring and adjusting its own alignment during normal automatic operation, but giving switch over to the manual system in event of loss of lock or other automatic-system failure. On recovery of lock, the system would switch itself back to automatic operation, giving minimum disturbance. This system will be very similar to the one currently being set up for initial tests on the 40-meter prototype with an IBM PC as a simple control computer.

An automatic alignment system is an essential feature for a 4 km interferometer, and the Fabry-Perot cavity autoalignment device already demonstrated on one arm of the 40-meter prototype provides a very precise and drift-free way of achieving this, as indicated in this design. The system may appear slightly complex overall, but it should be noted that it is made up mainly of many identical copies of a few basic units which will be designed to be suitable for small-scale quantity production.

The simplified schematic diagram given shows only one of a large number of possible design variants, and is intended to illustrate more the general approach than the final details. In this laser stabilization system, for example, it may prove useful to supplement the Pockels cell phase shifter shown in the first loop by an acousto-optic frequency shifter; or it may be useful to feed back a trimming signal from the second stage stabilizing loop to the first one. Current work with prototype interferometers is giving practical experience of these and other variants of the basic stabilization system. The arrangement shown in the figures is a fairly straightforward one, and a reasonable choice for the present design.

References

- F-1 R. W. P. Drever, J. L. Hall, F. V. Kowalski, J. R. Hough, G. M. Ford, A. J. Munley, H. Ward, *Applied Physics* **B31** (1983), 97.
- F-2 R. W. P. Drever, J. Hough, A. J. Munley, S.-A. Lee, R. Spero, S. E. Whitcomb, J. Pugh, G. Newton, B. Meers, E. Brooks III, Y. Gursel, "Gravitational wave detectors using laser interferometers and optical cavities: 1. Ideas, Principles, and Prospects" *Quantum Optics, Experimental Gravity, and Measurement Theory* ed. P Meystere and M. O. Scully, (Plenum Publishing, 1983), pp. 503-514.
- F-3 G. A. Kerr, N. A. Robertson, J. Hough, C. N. Man *Applied Physics* **B37** (1985), 11.
- F-4. N. A. Robertson, R. W. P. Drever, I. Kerr, J. Hough, *J. Phys. E, Sci. Instr.* **15** (1982), 1101-1105. J. Hough et al. "Gravitational wave detectors using laser interferometers and optical cavities: 2. Some practical aspects and results" *Quantum Optics, Experimental Gravity, and Measurement Theory* ed. P Meystere and M. O. Scully, (Plenum Publishing, 1983), 515.
- F-5 J. E. Faller, R. L. Rinker *Dimensions* (September 1979) p. 25.

Appendix G

PRELIMINARY DESIGN OF A LIGO DELAY LINE RECEIVER

This appendix presents two conceptual delay line receiver designs to meet the initial LIGO sensitivity goal (middle curves in Figures A-4a,b,c). The designs are derived in part from the experiences with the 1.5 meter prototype at MIT, the 30 meter system at the Max Planck Institute in Munich, and the Fabry-Perot systems at Caltech and Glasgow.

The "L" configuration

Figure G-1 shows a schematic diagram of a LIGO delay line receiver in an "L" configuration which is similar to the 1.5 meter system. The light source is a 100 watt CW Nd:YAG laser operating at one micron. The input and output coupling of the interferometer is accomplished with single mode, large diameter optical fibers. The fiber ends are melted into lenses which, along with weak auxiliary lenses, mode match to the optical cavities. Each coupler is mounted on a separately suspended and servo damped mass. The input beam is divided by a symmetric dielectric coated beam splitter mounted on a multiple isolated mass. The beams enter the two orthogonal delay line cavities through the input holes in silicon substrate mirrors. The mirrors have multilayer dielectric coatings on their curved surfaces and are polished on their flat surfaces. The beams in each cavity bounce back and forth between the mirrors making a circular pattern of spots on the mirrors. The spots are separated so that the intensities incident on the mirror coatings are minimized. The design is configured for 34 passes* of the beam in each cavity (a storage time of 0.5 milliseconds) before the beams emerge through the output holes in the mirrors. The position and rotation of each mirror is controlled electrostatically relative to a suspended guard mass (not shown) in a multiple suspension system. On exiting the cavities, the beams pass through Brewster angle longitudinal electrooptic phase modulators driven by RF in antiphase to impress sidebands on the optical carriers for subsequent fringe interrogation. The two electrooptic crystals are mounted together on a separately suspended mass. The phase modulators are also used as phase controllers in a servo fringe locking system with large bandwidth but small dynamic range. Large dynamic range, lower bandwidth fringe control is asserted by electrostatic controllers on the mirrors. The beams are recombined on a separate beam splitter which is identical in construction to the input splitter. Both the symmetric and antisymmetric outputs are coupled out of the interferometer to high power photodetectors. The figure does not show the auxiliary light beams and area detectors used for mirror pointing or the separate low power interferometers that control the relative positions of the the two input mirrors and the beam splitters.

* Figures G-1 and G-3 refer to a 36-pass delay line, but the 34-pass geometry is preferable because of differences in the spacing of the spots on the mirrors. The curves in Figure 3 are only slightly different for a 34-pass geometry.

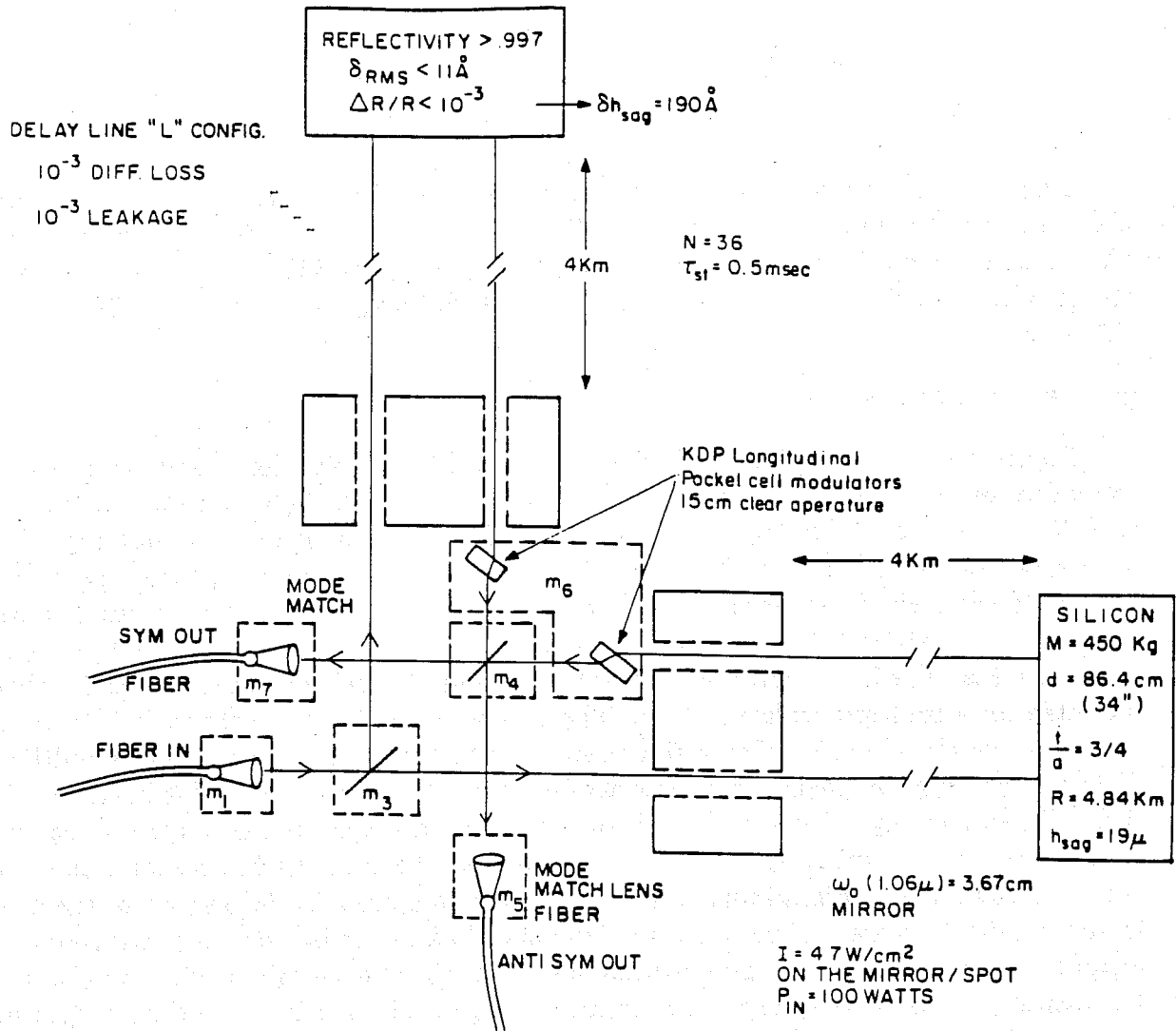

Figure G-1: Schematic diagram of a LIGO delay line receiver in an L configuration.

Positive attributes of the design

The principal advantage of the design is its simplicity and minimization of optical components in the transmission path that can distort wavefronts and scatter light. The mirrors can be monolithic and do not have to be transparent so that an optimized tradeoff of such material properties as substrate mechanical Q, thermal expansion, and the quality of the polished surface can be made over a large range of materials. The delay line interferometer is operated on or near the "white light" fringe so that laser frequency stabilization is not required except as one means of controlling the fringe noise of scattered beams from stationary scatterers and to relax the requirement of strict path length equality. Control of noise from scattering uses the technique of reducing the coherence length of the light by random phase modulation, which is effective for both stationary and moving scatterers. The method is easier to implement in a four

kilometer system than the 1.5 meter system since the time delays between the main beam and the principal scattered beams, originating from different spots on the mirrors, are larger. Beam jitter is controlled by the optical fiber coupling at the input and scattered fields other than those that overlap with the mode defined by the exit output fibers are rejected. This serves not only to reduce the total scattered intensity but also to relax the demands on the uniformity of the photodetector. The fringe phase is, in first order, nearly insensitive to translation of the mirror perpendicular to the optic axis as well as to mirror rotation. This is most strictly true for a completely reentrant geometry, one in which the input and output beams are coupled through the same hole in the mirror. In a four kilometer system the two beams in such a configuration would be separated by an angle of 100 microradians so that auxiliary optics placed in the main beam would be required. The choice made in the design is to use two coupling holes at the cost of a small first order sensitivity to rotation and translation in order to avoid additional components. The relative ease of alignment of the system is preserved. Another possible attribute is that since the beams do not interfere in the cavity, effects associated with the "spring constant" of the optical field are unimportant. The requirements for the vacuum system are relaxed since the amplitude of optical phase fluctuations due to fluctuations in the column density of the residual gas in the cavities is reduced relative to a single beam interferometer in the ratio of the square root of the number of beams.

Developmental requirements and disadvantages of the design

The delay line receiver requires additional development of mirrors of the size and surface quality shown in Figure G-1, modestly large aperture electrooptic crystals, and high power optical fibers and lasers. There is a tight constraint upon the mirror curvature error driven by the need to satisfy simultaneously the geometric constraint that the beam exit through the exit aperture as well as the requirement of optical path length equality in the two arms. The use of two independently suspended beam splitters relaxes this constraint slightly. Representatives of Kodak and Perkin-Elmer maintain that our requirements are less stringent than those of mirrors for surveillance satellites and the Space Telescope, and that mirrors can be made to our specifications. Kodak has experience with nearly flat, super-polished mirrors on this scale, and Perkin-Elmer has the capability to measure the quality of such mirrors. We are concerned that a mirror initially made to specification might deform during use as a result of gravity loading or thermal deformation under high intensity illumination. Thus, there are alternative strategies to meet the requirements of beam geometry and optical path length equality. One possibility is to servo the mirror radius electrostatically. A second is to include a small steering mirror in the delay line cavity. Such a mirror, which would reflect the beam only once, would be movable along the optical axis of the cavity to vary the optical path length and it would be steerable to achieve the beam geometry condition. A third possibility is to use the closed path geometry which is described below. None of these three ideas has been tested. The constraint on surface microroughness is a result of the requirement for low scattering at the mirror surface. Coatings of this quality are achievable; Battelle Northwest uses plasma deposition to coat substrates as large as one meter diameter for the military. Delay line receiver mirrors are large enough to serve as the interferometer masses. The ratio of thickness to radius is chosen to put

the frequency of the lowest order normal mode outside of the frequency band of the gravitational wave search.

The delay line receiver requires longitudinal Pockels cell phase modulators with 15 cm clear apertures. KDP crystals of even larger size are made and used at Lawrence Livermore Laboratory, but they have not been tested for this application. The optical uniformity of the crystals and the transparency and scattering amplitude of the transparent electrodes are critical concerns. The crystals are not required to withstand high optical intensities; the peak intensity is small since the beam diameter is large. Similarly, high intensity capability is not necessary in the Pockels cells used for scattering suppression and laser frequency servo, because these cells will be situated between the laser oscillator and the power amplifier, and only a low power beam will be incident upon them. If large aperture crystals are not suitable for the delay line receiver, then one might focus the beam into a smaller crystal, but that crystal must be able to withstand optical intensities greater than the damage threshold in crystals currently available. Alternatively, one might construct a large crystal with an array of smaller crystals.

Optical fibers of sufficiently large diameter have not yet been developed. We know that optical loss is lower at one micron than at 0.5 micron, so it should be possible to transmit 100 Watts, but fibers of larger diameter than we have now will be required. Nd:YAG lasers which can generate 100 Watts of single mode light do not exist at present, but the development of this laser is a major development item both within the LIGO project and in industry. It is likely that adequate lasers will soon be available. Light recycling is not shown in Figure G-1, and it would require development. There is no reason that light recycling could not be used in the delay line receiver, though it does demand a level of frequency stabilization which is not otherwise required to meet the initial design sensitivity goal of Figure G-3.

An intrinsic limitation of the delay line receiver is that the storage time cannot be increased by large factors. Small increases are possible through the use of non-circular spot geometries, which might be achieved through the use of either astigmatic mirrors or steering mirrors. Nevertheless, Fabry-Perot and tagged-beam receivers hold greater promise to enhance the storage time.

Closed geometry delay line concept

An alternative to the "L" configuration is the closed path delay line receiver shown in Figure G-2. The most significant advantage of this geometry is that it relaxes the constraint on mirror radius error. The equality of optical path length is automatically satisfied and the cavity lengths can be individually adjusted to satisfy the beam geometry condition. The closed path geometry has slightly enhanced sensitivity relative to the "L" configuration in the band above 100 Hz. This is due in part to the increased storage time, but also because the transfer function of the configuration is larger at midband frequencies at the expense of low frequency sensitivity. Nevertheless, the design is such that the performance at low frequencies is still dominated by stochastic forces rather than Poisson noise.

The principal disadvantage of the closed path geometry is the multiplicity of optical

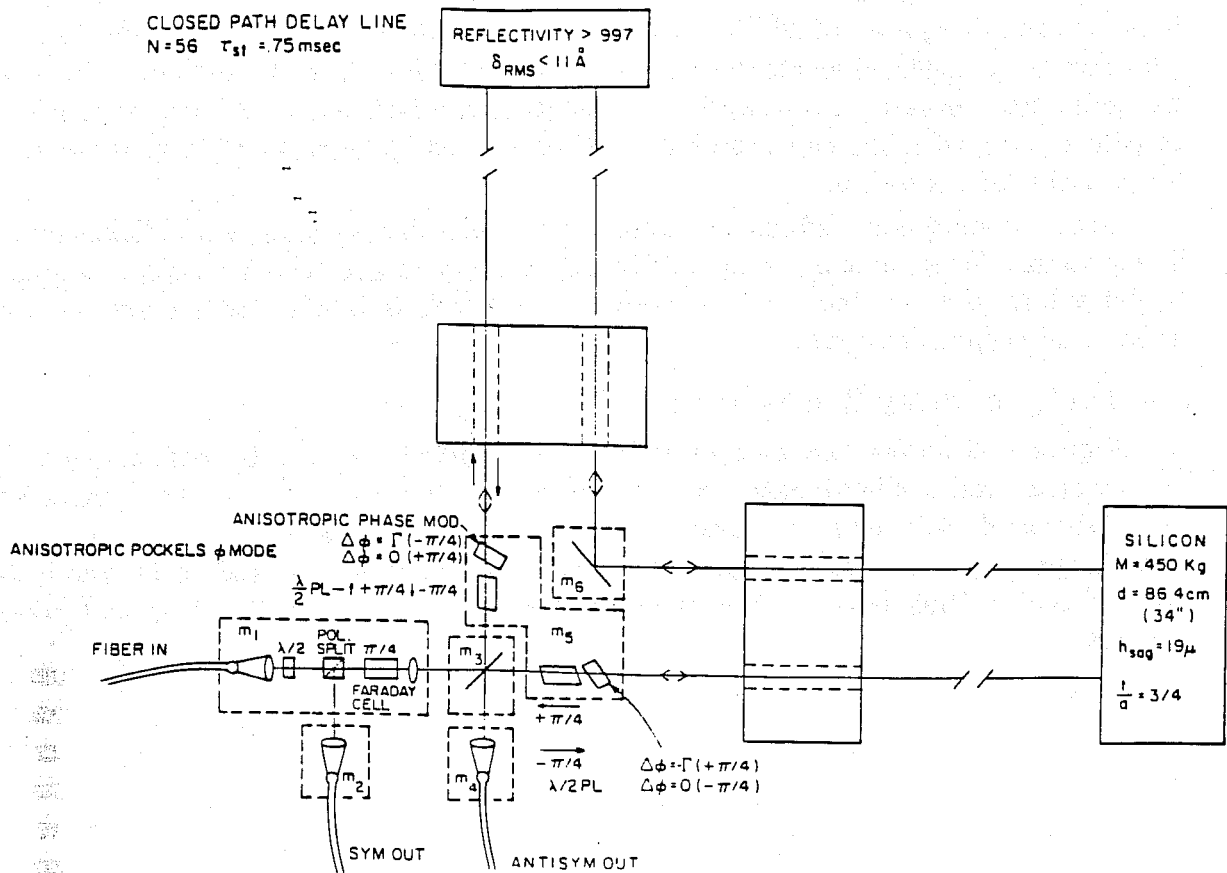

Figure G-2: Schematic diagram of a closed-path delay line receiver.

components required and their attendant losses and distortions. A minor disadvantage is the larger probability of backscatter from overlapping beam spots, though this is not serious as it is controlled by the reduced coherence of the light.

In the closed path design of Figure G-2 each beam traverses each cavity 28 times for a total of 56 passes and a storage time of 0.75 msec. Each beam passes through both Pockels cells, but a beam is modulated by only the Pockels cell through which it passes after having passed through both delay lines. Consider the beam which is reflected from the beam splitting surface on mass 3. Its plane of polarization has been rotated by $\pi/4$ by the Faraday cell, and it traverses the first Pockels cell perpendicular to the modulation axis of that cell, so no modulation results. After traversing one delay line, it is reflected by the mirror on mass 6 into the other delay line, and then passes through the other Pockels cell and is modulated. Similarly, the beam which is initially transmitted by the beam splitter on mass 3 is only modulated by the second Pockels cell through which it passes. The polarization states of the outgoing beams are such that they interfere at the beam splitter.

Proposed work on delay line receivers when and if reinitiated

Delay line research has been halted for the present time in favor of development

of Fabry-Perot receivers. If delay line receiver development is restarted, then efforts would be directed toward construction of an "L" configuration prototype receiver in the 5 meter vacuum system at MIT. Such a prototype would use mirrors of 8 inch diameter. Work on large aperture electrooptic modulators would have to be initiated. Some effort has gone into development of specifications for large mirrors; that work would have to continue along with the development of test methods for mirrors of large diameter and large radius of curvature.

Some development efforts are common to both Fabry-Perot and Michelson delay line systems. Work that is being carried out at present and which would be applicable to delay line receivers includes development of Nd:YAG lasers, large diameter optical fibers, and suspension systems.

Sensitivity of delay line receivers

Figure G-3 shows the anticipated strain sensitivity of an L configuration delay line receiver and a closed path receiver which are designed to meet the initial LIGO sensitivity goal. Seismic noise dominates the noise spectrum at low frequencies, thermal noise in the suspension is dominant at frequencies of roughly 50 to 100 hertz, and Poisson noise is the limiting noise source at higher frequencies. 100 watts of optical power is assumed.

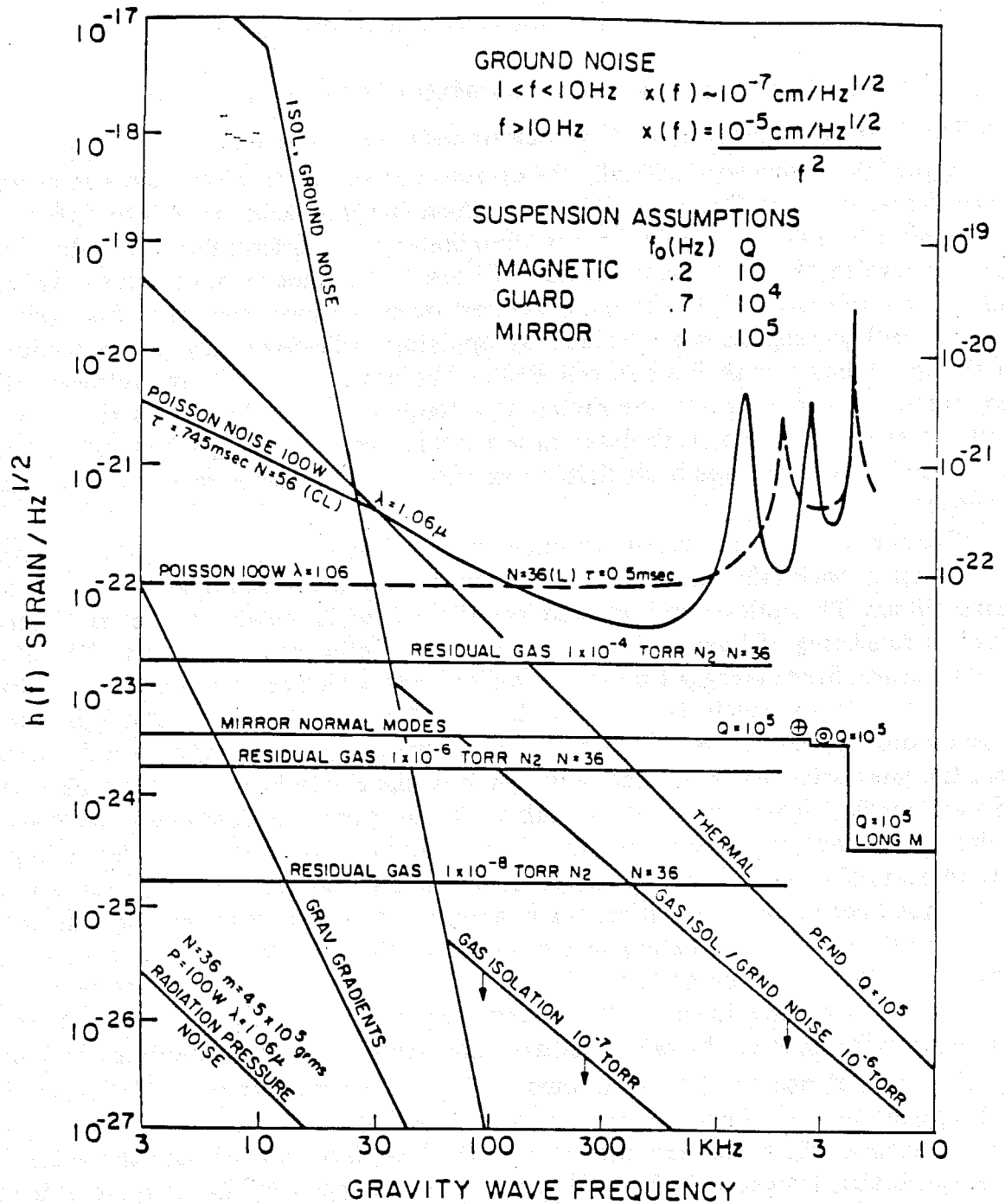

Figure G-3: Anticipated strain sensitivity of possible LIGO delay line receivers.

APPENDIX H

TECHNICAL DETAILS OF THE PROTOTYPE INTERFEROMETERS AND ASSOCIATED TECHNIQUES

H.1 Detailed Description of the 40-Meter Prototype

(a) The Technique to Maintain the Interferometer on Resonance

Figure H-1 shows schematically the optics and electronics of the 40-meter prototype interferometer, as of October 1987. An argon ion gas laser, tuned to 514 nm and operating in a single longitudinal mode, illuminates the interferometer. The fluctuations in laser wavelength and the low-frequency (below 10 Hz) motion of the suspended cavity mirrors are too large by far to maintain resonance without electronic feedback. The needed feedback signals are obtained by applying radio-frequency phase modulation to the input beam with Pockels cell PC4. The optical phase is modulated with an amplitude of approximately one radian at a frequency of 12 MHz. At this frequency laser intensity noise from turbulence in the forced flow of cooling water, plasma noise, and other spurious sources is negligible compared to fluctuations from photon counting statistics.

The modulated light passes through various components: a Faraday isolator to prevent stray back-reflections, a pair of lenses to match the beam to the cavity, and a beamsplitter. The split beam is steered into the pair of 40-meter cavities via directional couplers consisting of beam splitting polarizers and quarter-wave plates. The cavities exhibit an amplitude storage time of 0.5 milliseconds, which corresponds to a bandwidth of 300 Hz. Consequently they reject the 12 MHz sidebands, and the light striking photodiodes D2 and D3 is the vector sum of two components: the modulated beam from the laser reflected by the input mirror, and the cavity beam, without modulation sidebands which "leak" back out through the input mirror. In resonance, the laser and cavity beams have opposite phase, and the intensity on the photodiodes is a minimum. Due to scattering and absorption losses in the mirrors as well as imperfect matching of the input beams to the cavities, the minimum intensity is not zero, but rather 15% of the input intensity. If the mirror separation or the laser wavelength moves slightly away from the resonance condition, the 12 MHz component of the photocurrent in the detectors increases linearly. These error signals are demodulated by r.f. mixers coherently referenced to the same oscillator that applies the phase modulation to PC4.

The error signals from the two arms are fed back asymmetrically. The signal from D2 is applied to a set of controlling elements consisting of a Pockels Cell PC1 inside the laser, a piezoelectric transducer mounted on the laser front mirror, and the extra-laser phase-correcting Pockels cell, PC3. These correction paths combine to match the laser wavelength to the length of one arm, accurately maintaining resonance. The other arm is brought into resonance by mechanically adjusting its length, using the signal from photodiode D3 which is applied to transducers that move one of the end masses.

(b) Reduction of Spatial and Temporal Fluctuations in the Laser Beam

The Munich Group proposed [H-1] that small fluctuations in the geometry of the laser beam could be a source of noise and described a "mode cleaning" cavity to reduce

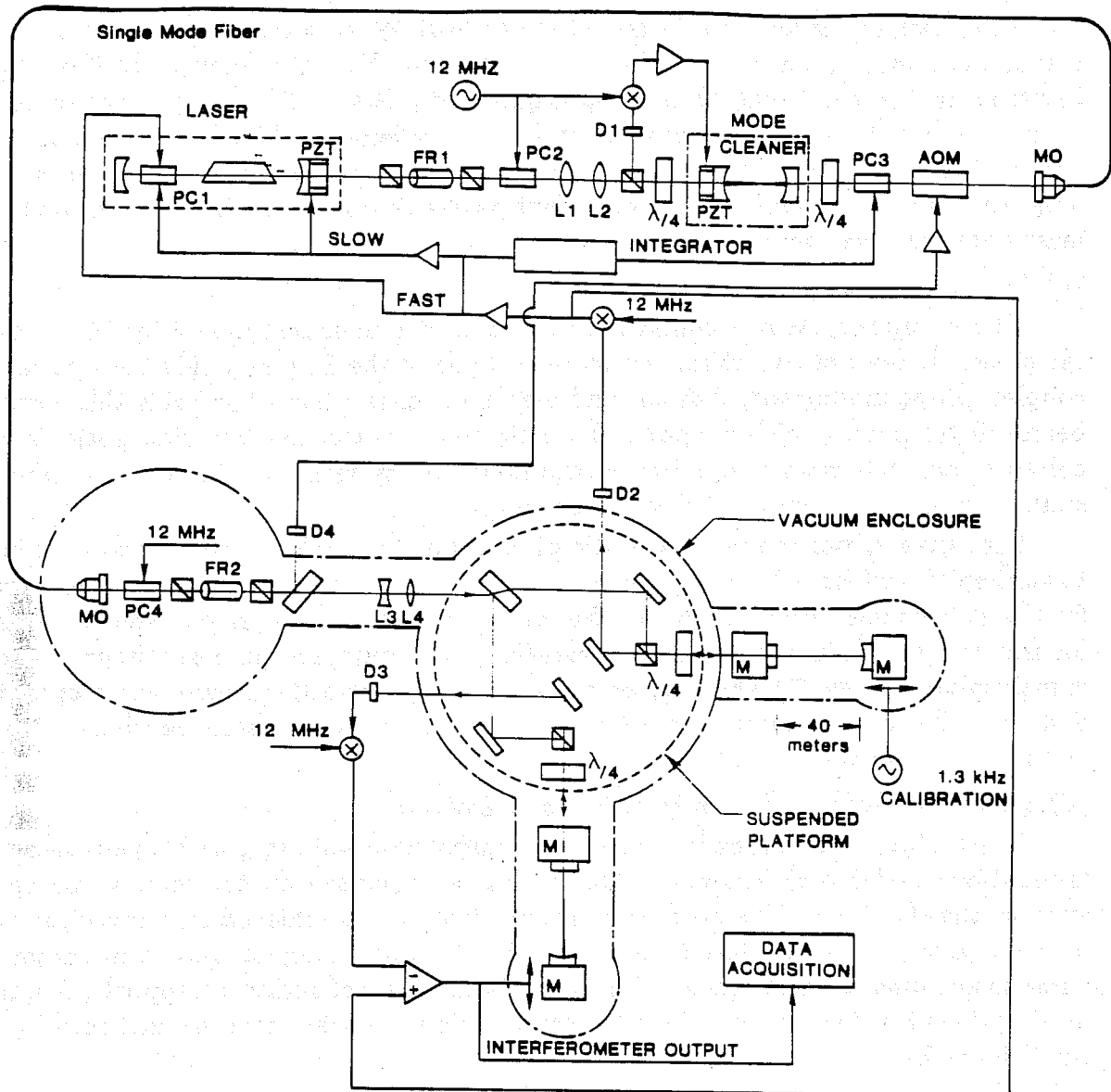

KEY TO SYMBOLS:













- | | | | | | |
|---|--------------------------------|---|----------------------------------|---|----------------------------|
|  | Beam-splitting Polarizer |  | PZT
Piezo-electric transducer |  | rf demodulator (mixer) |
|  | PC
Pocket cell |  | Quarter-wave plate |  | Sine-wave generator |
|  | M
Test Mass with mirror |  | FR
Faraday rotator |  | Amplifier |
|  | L1 - 4
Mode-matching lenses |  | AOM
Acousto-Optic Modulator |  | Photodiode/amplifier |
| | | | |  | MO
Microscope objective |

Figure H-1: Schematic diagram of the 40-meter system. Refer to text for details.

the fluctuations. Subsequently, an alternative method for spatially filtering the beam by passing it through a single-mode optical fiber was suggested by the MIT Group.

Both techniques are used in the 40-meter prototype: the beam first passes through a mode cleaner, which is stabilized to the laser in the same manner as the 40-meter cavities, and is then sent through a single-mode fiber. The mode cleaner is made from mirrors attached to a thermally stable 34-cm long block of ULE glass, and has a bandwidth of 200 kHz. It filters out high-frequency temporal fluctuations in the laser amplitude and wavelength. The beam next passes through the fiber, which couples the laser light into the vacuum system.

(c) Vacuum System

The vacuum system is composed of four 45-cm chambers joined by 20-cm diameter pipes. There are two chambers at the corner of the L. One holds the optical fiber coupler, phase modulator, isolator, and matching lenses; the other holds the suspended beamsplitter mass (which supports the main beamsplitter and steering optics and circulators) and the masses attached to the input cavity mirrors. The end chambers are simpler, holding one suspended test mass each.

Four gate valves at the ends of the pipes allow the tanks to be individually vented to atmosphere without breaking vacuum in the pipes. A system of bellows compensates for the atmospheric force. Each chamber can be run through a cycle of venting, opening for inspection or minor modification, resealing, and pumping, in a few hours. Vacuum is maintained by two 10,000 liter/sec pumps midway down the pipes—one a cryopump, and the other a turbomolecular pump with magnetically levitated bearings. Pressure at the end stations is $4 \cdot 10^{-5}$ torr.

(d) Seismic Isolation, Wire Suspension, and Damping

The prototype is housed in a custom-manufactured building, with separate isolated foundations under each chamber. Optical tables mounted on commercial air springs support the chambers. The bulk of the seismic isolation is achieved by three-layer stacks of lead and rubber inside the chambers, and by the 30-cm long, 80 micron diameter steel wires suspending the test masses. The wires form a pair of slings to support the masses, leaving them free for motions along the cavity axis and constrained against rotation and tilt (Figure H-2).

If left undamped the masses are excited by seismic noise to a pendulation amplitude of 10^{-5} meters peak to peak at the suspension resonance of 1 Hz. The motion would correspond to 10^5 fringe widths or about 10^{11} times the kHz bandwidth displacement sensitivity of the interferometer. These motions are measured with sensors using a light emitting diode, a photodetector and a shadow mask which is placed on the moving mass. The signals from these sensors are combined with the interferometer output and fed back to piezoelectric transducers attached near the suspension points to damp the pendulum motion and to provide the low-frequency gain necessary to maintain optical resonance.

(e) Orientation Control

Figure H-2 also shows how the mass orientation is sensed and controlled [H-2]. Auxiliary Helium-Neon lasers form 40-meter long optical levers with the cavity mirrors

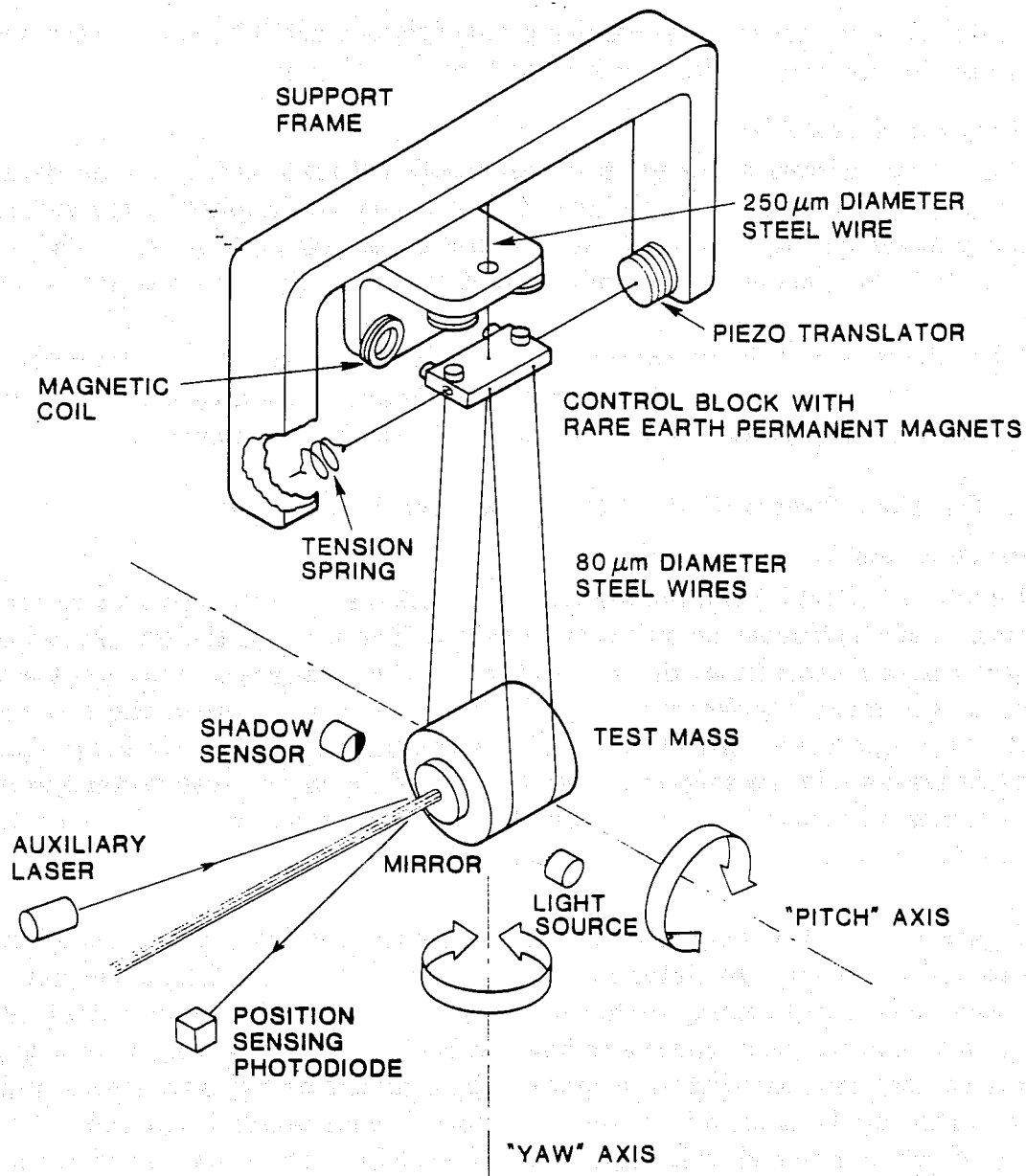

Figure H-2: A schematic drawing of a typical test mass in the 40-meter system, showing the optical lever used for sensing rotation ("yaw") and tilt ("roll") of the mass, and the coils used to apply feedback near the suspension point. The beam from an auxiliary laser at the far end of the pipe strikes the cavity mirror and returns to a two-axis position sensing photodiode. The electrical signal is sent back to coils that interact with magnets on a control block near the suspension point, twisting and turning the block to keep the mass aligned. (The separation between the coils and magnets is exaggerated for clarity; in practice the spacing is adjusted to keep the applied torques insensitive to ground motion.) Also shown are the sensor and translator that damp longitudinal pendulum motions. A modulated beam of light from a light emitting diode is partially blocked by the edge of the mass, producing a spot of light on the photodetector proportional in intensity to the mass's displacement. This signal is filtered, amplified, and applied to a piezoelectric translator at the top, providing cold damping of the pendulum.

to monitor the orientation. The resulting angle signals are fed back to electromagnetic coils near the suspension points to keep the cavities aligned.

(f) Mirrors and Test Masses

The cavity mirrors are made from superpolished fused silica, 3.8 cm diameter by 1 cm thick (see Figure H-3). Multilayer dielectric coatings applied to the surfaces have measured losses due to absorption and scattering of 100 ppm or less. These mirrors store the light long enough to optimize the 40-meter facility for detection of signals as low as 500 Hz.

The mirrors are optically contacted to fused silica masses, 10 cm diameter by 9 cm long. The lowest frequency mode of the mass is 29 kHz, with a Q of $9 \cdot 10^4$. Axial holes of 2.5 cm diameter provide a lossless optical path to the input mirrors.

H.2 Detailed Description of the 1.5-meter Prototype

(a) Structure and Vacuum System

Figure V-6 (Part V) is a photograph of the 1.5 meter prototype gravitational wave detector. It is constructed on two granite tables. The table in the foreground contains the laser and some associated optics; the table in the background supports the vacuum system of the main interferometer. Light is transported between the two tables by means of a single mode optical fiber which serves as a spatial mode filter. The three vertical tanks contain the support points for each of the mirror suspension systems, and the vacuum is maintained at 5×10^{-7} mm Hg by three ion pumps which are cantilevered out from the vertical tanks midway up each tank.

(b) Optics

Figure V-7, Part 5 shows a block diagram of the detector. Each arm of the interferometer is a 56 pass 1.46 meter reentrant optical delay line. The delay line consists of two spherical mirrors facing each other to form a cavity. The beam enters the cavity through a hole in the near mirror and bounces back and forth making a circular pattern of spots on each mirror. When the spot on the near mirror has advanced a multiple of 2π around the circle, it exits from the same hole through which it entered. If the beam is properly mode matched, it is continuously focused by the cavity and the spot size on the mirrors remains constant.

The interferometer is illuminated with light from an argon ion laser operating in a single longitudinal mode at 514.5 nm. The beam passes through a LiTaO_3 crystal where it is phase modulated with wide band noise. The wide band variations of the phase reduce the spatial coherence length of the light so that light scattered out of the main interferometer and onto the photodetector will not cause spurious interference fringes with the main beam. The main beam is unaffected by the modulation because the interferometer is operated near zero path length difference in the two arms (the "white light" fringe).

The beam then passes into a single mode optical fiber. Fluctuations in the angle or position of the beam from the laser are converted by the fiber into intensity fluctuations, to which the interferometer is relatively insensitive. At the output of the fiber the light is mode matched into the delay lines with a commercial zoom lens and passes through a

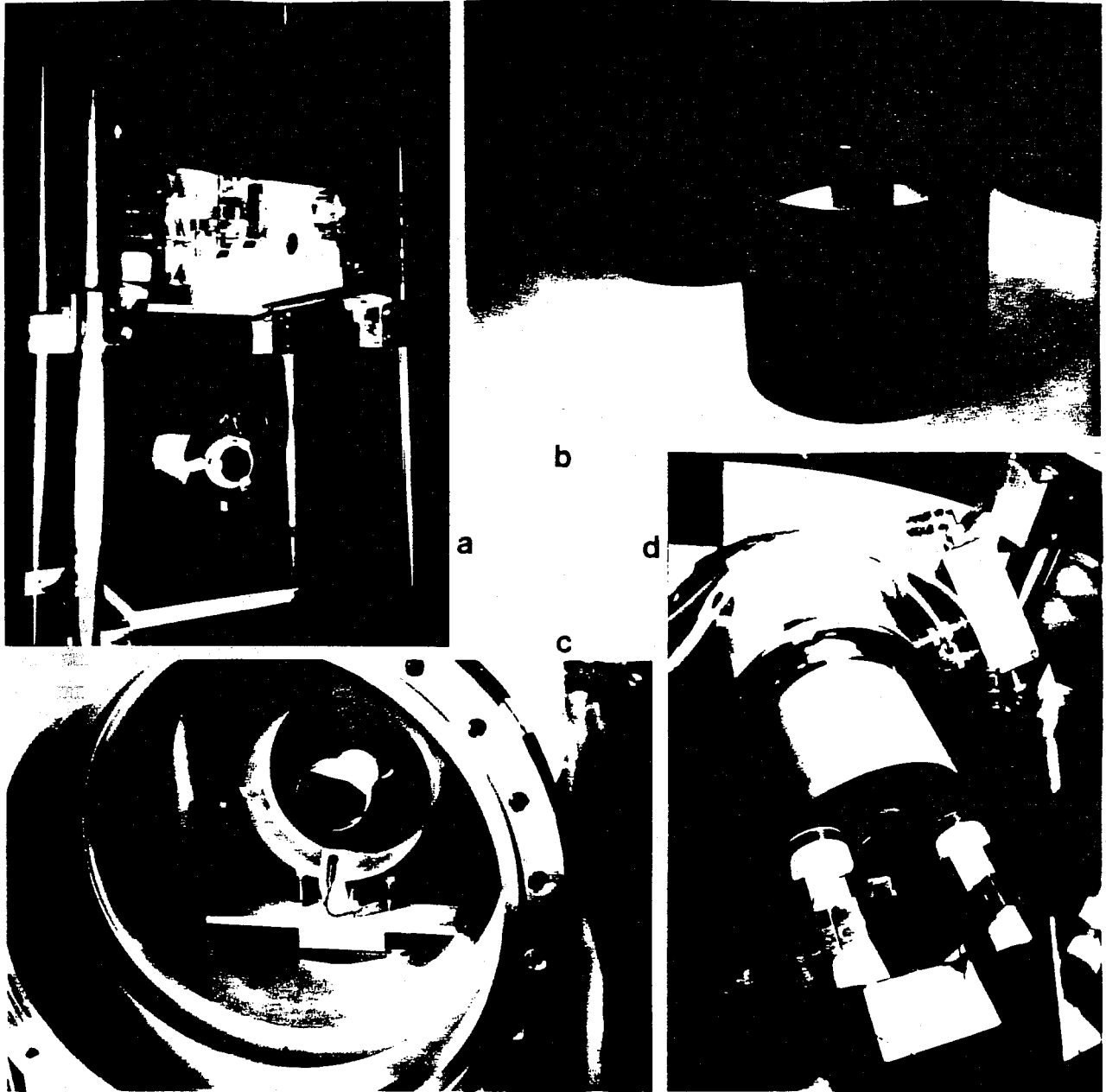
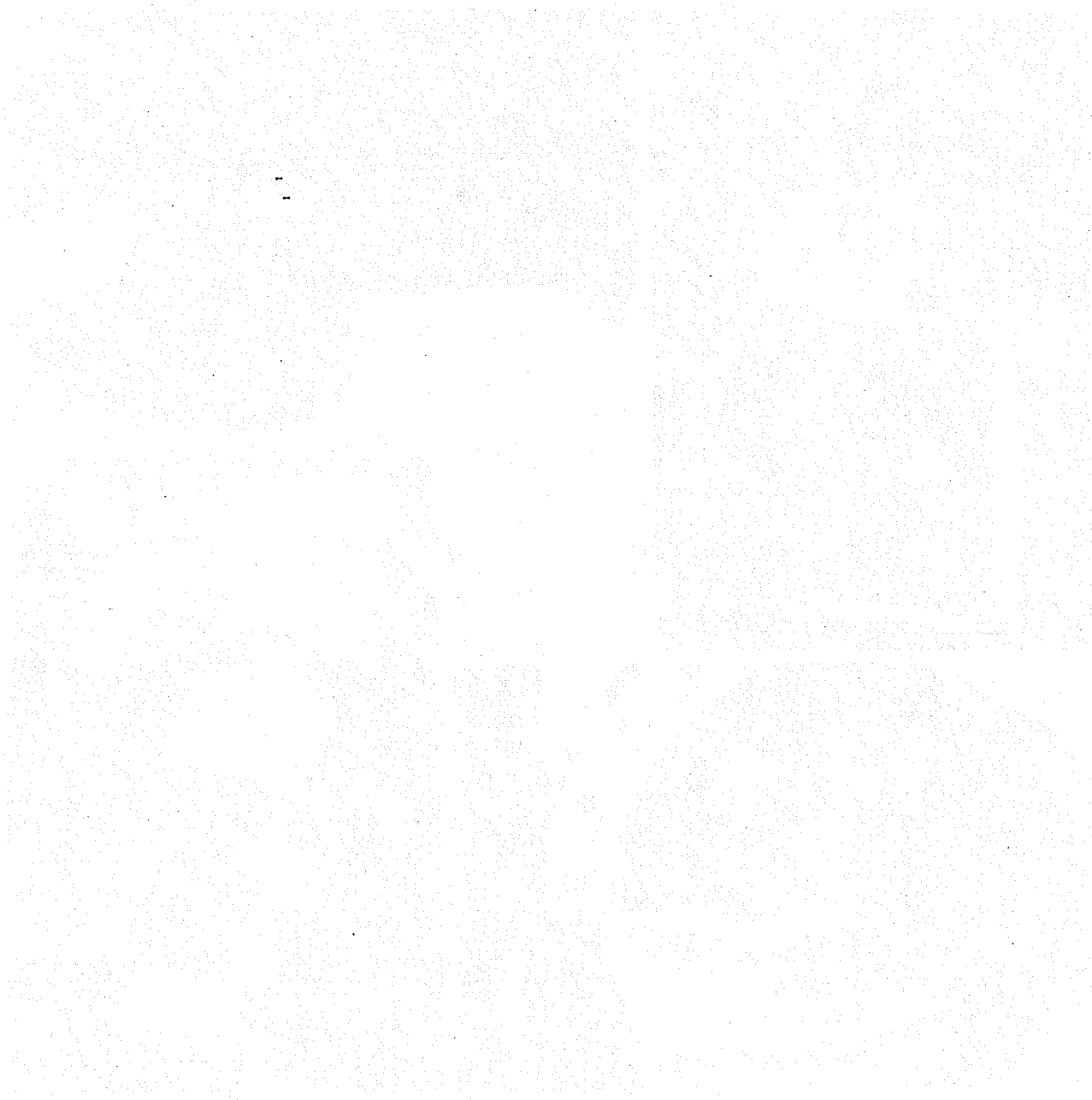

Figure H-3: Views of test masses and suspensions. (a) shows a previous-generation aluminum test mass (ca. 1986). The mirror is glued to a piezoelectric displacement transducer, which in turn is joined by glue to the mass. Also visible are the magnet coils used for orientation controls (cf. Figure H-2) and a lead and rubber stack, seen edge on, supporting the top plate. (b) shows a cavity mirror optically contacted to a fused silica mass. An earlier design made of brass is in the background. (c) shows one of the central masses suspended within its vacuum pipe. The shadowmeter below the mass senses its front edge for damping the 1 Hz pendulum motion. (d) shows an end mass with two types of force transducer: a pair of coils in the front to interact with magnets glued to the mass, and an electrostatic plate that interacts with the back surface, coated to be electrically conducting.



The following text is extremely faint and illegible due to the same degradation as the image above. It appears to be a block of text, possibly a paragraph or a list of items, but the characters are not discernible.

linear polarizer before entering the interferometer. The light must be linearly polarized so that the phase modulation, needed for the fringe interrogation, can be impressed by the AD*P electro-optic crystals at the output of the delay lines. A half-wave retardation plate is used to rotate the plane of polarization of the beam at the input to the fiber to optimize transmission of the fiber in the desired polarization state. The fiber is not polarization preserving, but it has been observed that the fiber will transmit a linearly polarized beam with only a 10% loss to the orthogonal polarization for several days without requiring readjustment. A photodetector after the polarizer provides a signal that can be used to stabilize the amplitude fluctuations of the beam after the fiber, but the additional servo has never been needed.

The output of the interferometer is monitored directly by a photodetector mounted so that the light is incident at Brewster's angle. An experiment is in progress to couple the light out of the interferometer with the same type of optical fiber by which it is injected. The spatial mode apodization performed by the fiber will reduce the contribution from scattering, and improve the contrast.

(c) Suspension

Each end mirror in the 1.5 meter prototype is mounted on a 8 kg aluminum mass suspended by a single wire to form a pendulum with a 2 second period. The 15 kg central mass supports two mirrors, a beam splitter, and two phase modulating crystals. Above the resonance frequency for a particular degree of freedom the mirrors are free to move. Near the resonance frequency the motion of the mirror is sensed and damped in all six degrees of freedom by an electrostatic damping system described below.

(d) Electronics

There are three separate systems in the electronics: an electrostatic mass damping system which controls the motion of the mirrors, a system which performs the fringe interrogation and locking, and another system to collect, store, and interpret the data.

Each aluminum mass supporting a mirror is surrounded on three sides by a cage formed of copper plates evaporated on glass. The position of the mass is sensed relative to the cage by monitoring the capacitances between the mass and the plates. The position information is differentiated to obtain the velocity and a damping signal proportional to velocity is fed back to electrostatically control all six degrees of freedom of each mass.

The interferometer is operated as a gravitational wave detector by holding the path length difference of the two arms constant and near zero. This is accomplished by keeping the system locked to a minimum in the interference fringe at the photodetector. The relative phase of the electric field in each arm is dithered by impressing a high frequency phase modulation on the light with an electrooptic crystal as it exits from each of the delay lines. The output is demodulated and fed back to the phase modulating crystals to maintain the dark fringe. A portion of the demodulated output is also used to move one of the end masses directly at low frequencies to keep the total path length difference within the $\lambda/2$ dynamic range of the phase modulating crystals.

The signal output of the antenna is taken from the error signal used to keep the interferometer on a dark fringe. The error signal is high pass filtered to remove large

low frequency components and then fed into the data collection system, shown in Figure H-4. The data collection system consists of a modified DEC MINC computer system using fast analog to digital converters and a buffered memory. The data stream is then interspersed with information about the state of the system collected at a much slower rate and written to tape. Relative timing for the system is provided by a rubidium clock; absolute timing is achieved by synchronization with WWV. The data collection system is capable of recording approximately 15 minutes of data continuously at 20 kHz and up to 60 minutes at 6 kHz. The data are analyzed offline.

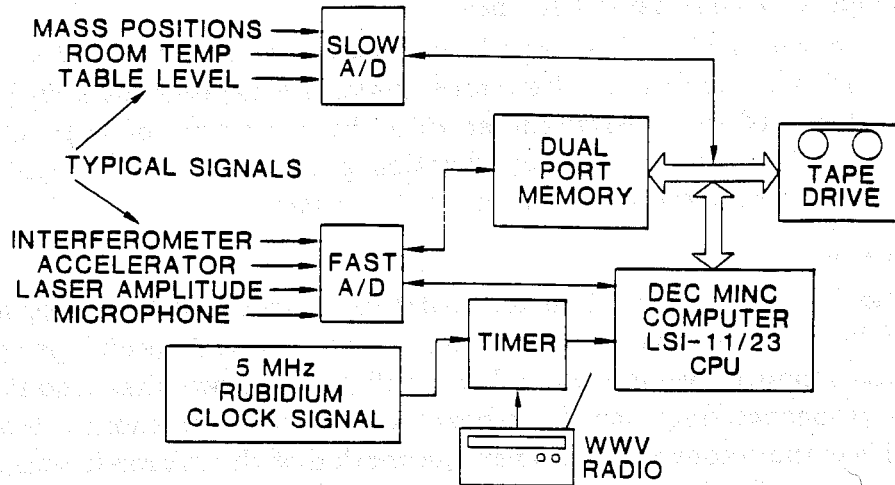

Figure H-4: Block diagram of the data acquisition system for the 1.5 meter prototype.

References

- H-1 A. Rüdiger, R. Schilling, L. Schnupp, W. Winkler, H. Billing, and K. Maischberger, *Optica Acta* **28** (1981), 641-658.
- H-2 S. E. Whitcomb, D. Z. Anderson, R. W. P. Drever, Y. Gursel, M. Hereld, R. Spero *Proceedings of the Third Marcel Grossmann Meeting on General Relativity* ed. Hu Ning, Science Press and North-Holland Publishing Company (1983), 1399.

APPENDIX I

DATA ANALYSIS DEVELOPMENT AND SEARCHES FOR GRAVITATIONAL RADIATION

1. Introduction

One aspect of the plans for a LIGO which must receive increasing attention is the need to develop techniques to analyze the data. Data reduction techniques are essential to extracting science from the observations, and since the hardware and software requirements are quite substantial it is imperative to begin planning for the necessary resources at an early stage in the design of the LIGO. It is already apparent from the work that has been done that recent technological improvements in data storage should be incorporated, and that even near-future supercomputers must be supplemented by special purpose hardware dedicated to the performance of specific analysis tasks.

We summarize below some of the work that has been done to develop data analysis techniques for interferometers. All of these techniques are directed toward the initial *detection* of a signal of astrophysical origin. Very little work has been done on the problem of optimally extracting the waveforms of the signal (the so called Inverse Problem).

2. Periodic Source: Known Period, Known Position

The 40-meter interferometer was used by Mark Hereld to conduct a search for the millisecond pulsar [I-1] PSR 1937+214 for his Ph.D. thesis [I-2]. The scheme developed by Hereld was to average the output of the detector synchronously with the phase of the pulsar, which could be calculated using the known position. The data were averaged in 30 minute pieces and recorded on tape. Subsequent Fourier analysis yielded narrowband ($0.6 \text{ mHz} = (30 \text{ min})^{-1}$) spectra, centered on the pulsar frequency at 642 Hz and its first harmonic at 1284 Hz. Polarization information was extracted by exploiting the different spatial sensitivity of the antenna to each polarization.

The magnitude of each spectral component was binned and compared with the probability distribution of amplitudes calculated for the noise in the instrument. Figures I-1 and I-2 show the results for the cross polarization at each frequency. The dotted curves show the instrument noise distribution; the vertical lines are the actual data. The arrow identifies the bin that would contain the center of the pulsar spectrum. The conclusion is that the observed spectrum is consistent with noise, with a formal 99.7% confidence sensitivity limit of approximately 1.5×10^{-17} in root mean square (RMS) strain.

3. Pulse Search using Templates

The 1.5-meter prototype was used to look for impulsive events with a set of templates developed by Daniel Dewey for his Ph.D. thesis [I-3]. The idea was to cross-correlate the actual data with an idealized representation of the expected signal and look for statistically significant matches.

Figure I-3 shows the set of 22 templates actually used. The set covers the range of center frequencies for a pulse wave packet from 800 Hz to 5.5 kHz, with a Nyquist

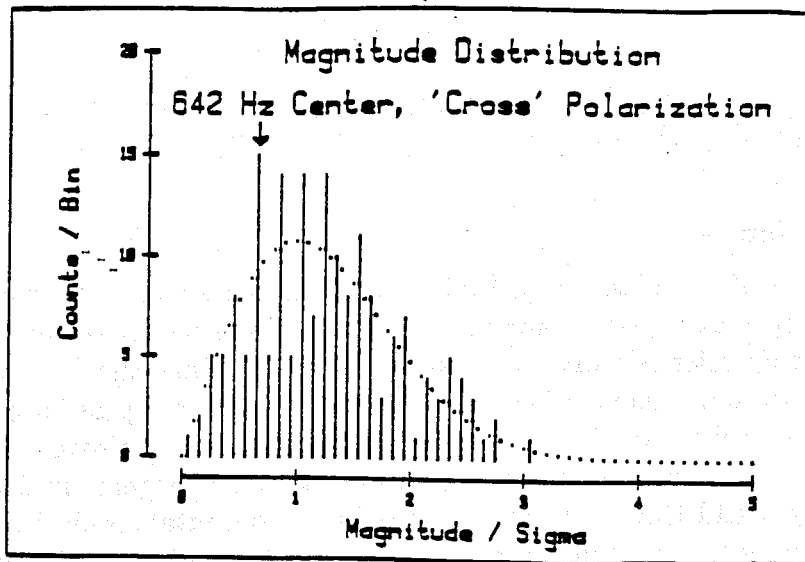

Figure I-1 The measured distribution of the magnitudes of spectral components in a 0.6 mHz wide spectrum centered at the 642 Hz millisecond pulsar frequency. The data were taken with the 40-meter facility and have been processed to extract the "cross" polarization. The dotted line is the noise distribution. The arrow indicates the bin containing the magnitude at the center frequency. (From [I-2], p. 58.)

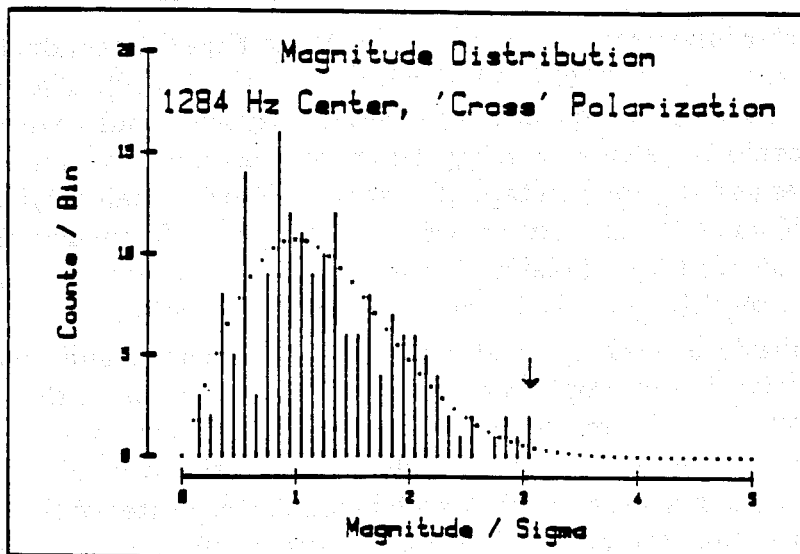

Figure I-2 The measured distribution of the magnitudes of spectral components in a 0.6 mHz wide spectrum centered at the 1284 Hz first harmonic of the millisecond pulsar frequency. The data were taken with the 40-meter facility and have been processed to extract the fixed polarization (the sensitivity to the two polarizations changes as the earth rotates). The dotted line is the noise distribution. The arrow indicates the bin containing the magnitude at the center frequency. (From [I-2], p. 58.)

frequency of 10 kHz. The maximum loss of signal to noise ratio (SNR) due to a mismatch between a real waveform and the idealized representation over this band is 75%. Each cross correlation of a finite length template with the data yields a pulse. The distribution of the amplitudes of these pulses should be a gaussian with variance determined by the

apparatus noise if the receiver noise is gaussian and there are no gravitational wave signals in the data.

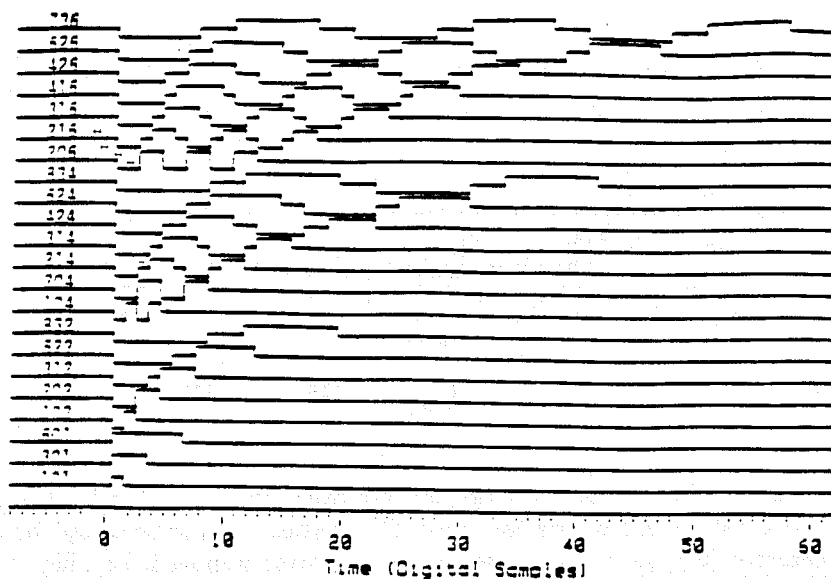

Figure I-3 The set of pulse templates used to search for impulsive events in data from the 1.5-meter facility. The numbers at the left of each template indicate the number of digital samples per cycle for which the template has the value ± 1 , the number of digital samples per cycle for which the template is zero, and the total number of half-cycles for the template. (From [I-3], p. 63.)

Figure I-4 shows the tail of a cumulative pulse height distribution. The slanted dotted line shows the instrument noise distribution, and there is a strong non-gaussian tail beginning at a SNR of approximately 6. Many of these tail events could be associated with electrical transients from the tape drive motor. With these known events removed, the final result was 12 detected events with an RMS strain amplitude $> 5 \times 10^{-14}$, and with an event rate of several per hour. Such events are much too large and too frequent to be of astrophysical origin without being detected in other gravity wave experiments. Such events in a LIGO detector will be removed by cross correlation of the two receivers at the two widely separated sites leaving only gaussian noise.

A similar search for burst sources in data from the recent supernova coincidence experiment is in progress at Caltech as part of Michael Zucker's Ph.D. thesis.

4. Periodic Sources: Unknown Period, Unknown Position

The 1.5-meter interferometer has also been used to conduct a search for periodic sources of unknown period and unknown position, thus exploiting both the broadband character of the detector and its nearly non-directional spatial response. The technique, developed by Jeffrey Livas for his Ph.D. thesis [I-4], is based on Fourier transform methods.

A sinusoidal signal from an astrophysical source is Doppler shifted by the relative motion of the source and antenna, and amplitude modulated by the non-isotropic spatial sensitivity pattern. For a specific position on the sky, the Doppler shift can be removed for all frequencies simultaneously. In principle, the entire sky can be searched

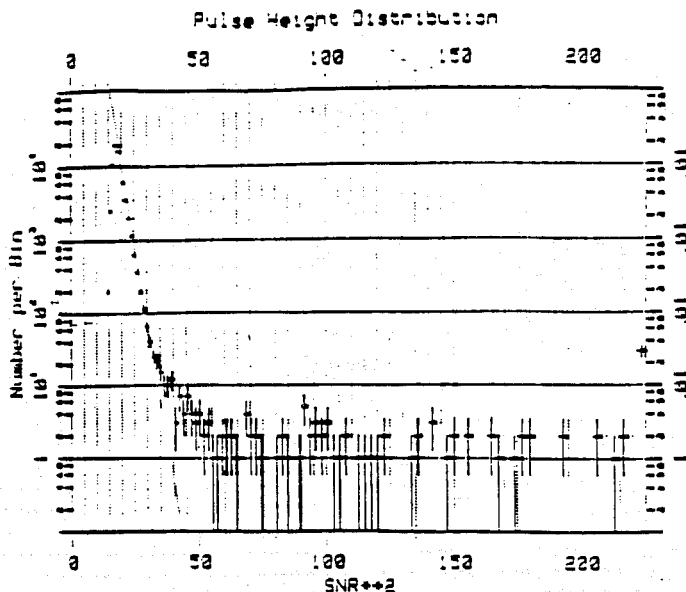

Figure I-4 Tail of the distribution of pulse heights from data filtered with the set of templates in Reference [I-3]. The dotted line shows the noise distribution. Error bars are for statistical counting errors. Events detected in more than one template have been removed, keeping only the pulse height with highest SNR. Most of the events in this tail can be attributed to electrical problems in the magnetic tape drive used to record the data. (From Ref. [I-3], p. 89.)

by repeating the procedure for different positions, but in practice the computational requirements far exceed the capabilities of even future general purpose supercomputers, and will likely require the development of a special-purpose computer.

A complete sky search was accomplished with a series of short (15 minutes of data = 2^{24} points) Fourier transforms taken over a one week baseline, but with limited sensitivity because of the short length of the transforms. However, a Cray 2 supercomputer was required for the computations even at this level. Figure I-5 shows a small portion of one of these transforms, which has a frequency resolution bandwidth of 1 mHz. The obvious peaks in the spectrum were flagged by the detection algorithm, but diagnostics show them to represent resonances in the apparatus, not real signals. Figure I-6 shows the distribution of amplitudes of a complete transform. The solid line is the distribution based on the instrument noise. The arrow indicates the detection threshold.

The final result was an upper limit of approximately $2 \times 10^{-17} (2 \text{ kHz}/f)^2$ in RMS strain in the band from 2-5 kHz, with no signals detected.

5. Template Search for Coalescing Binaries

One of the most promising sources of gravitational radiation is the signal expected from a coalescing binary star system in the final stages of collapse. The expected signal is a chirp whose center frequency increases with time over the duration of the impulse. The waveforms belong to a family of curves that, for fixed polarization (i.e., a detector sensitive only to *one* linear combination of h_+ and h_\times), are a function only of the masses of the constituents. Sheryl Smith at Caltech has developed an algorithm [I-5] to search for this one-parameter family of signals. The data are distorted according to the expected variation of the phase of the waveform, resulting in a sinusoidal waveform if a

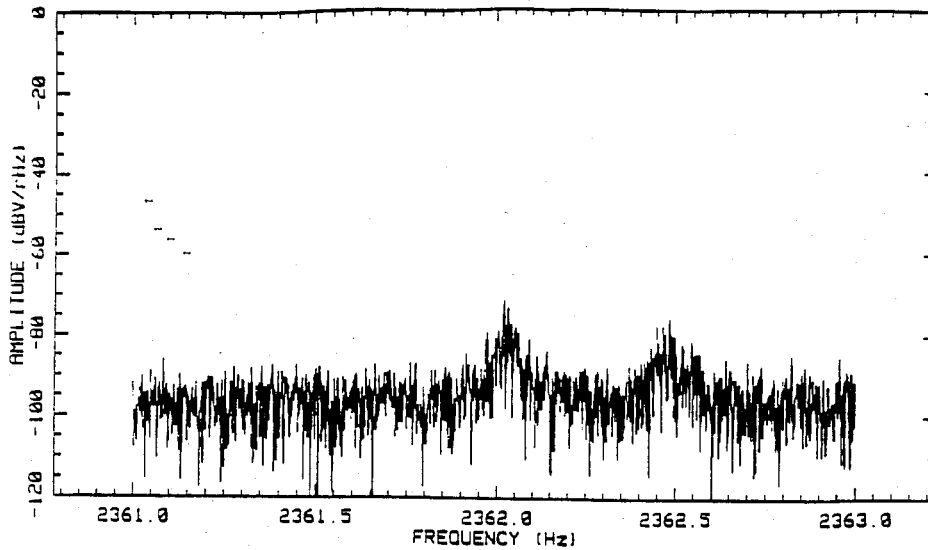

Figure I-5 Small section of a high resolution (1.2 mHz) power spectrum near resonances in the 1.5-meter prototype. Detected on an initial pass through the spectrum, these peaks were identified as apparatus resonances by subsequent diagnostics. (From Ref. [I-4], p. 90.)

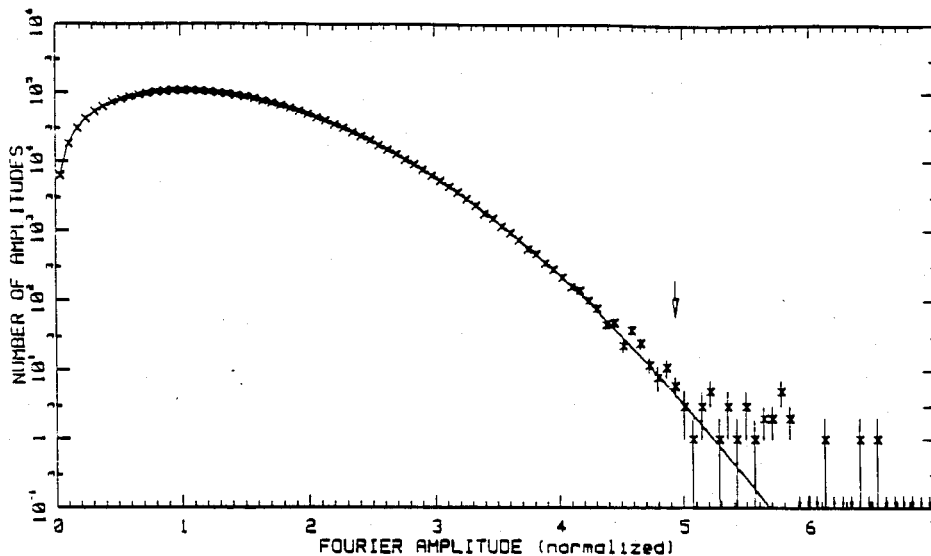

Figure I-6 Measured distribution of the magnitudes of the spectral components of a high resolution power spectrum from 2-5 kHz. Data are from the 1.5-meter facility. The solid line is the expected distribution. The arrow indicates the detection threshold. (From Ref. I-4, p. 84.)

signal is present. The distorted data are then Fourier transformed and the spectrum is searched for statistically significant peaks.

References

- [I-1] Backer, D.C. et. al., *Nature*, 300, 615, (1982).
- [I-2] Hereld, M. Caltech Ph.D. thesis (1983) Physics, "A Search for Gravitational Radiation from PSR 1937+214"

APPENDIX J

OTHER LIGO EXPERIMENTS AND TECHNOLOGY APPLICATIONS

The major payoffs of the LIGO project will be tests of the laws of gravity and the opening of the new field of gravitational wave astronomy. However, the LIGO facilities may also be useful in other areas of research. The long baseline vacuum system, if augmented in a later phase of the LIGO by closing a triangle within the initial L configuration, will find application in experiments using precision laser gyros. The potential sensitivity and precision of laser gyros built in the LIGO facilities is such that measurement of the predicted "dragging" of the local inertial frame by the earth's rotation may be possible if adequate methods of defining a reference frame are found, and these experiments may set improved limits on more speculative preferred frame effects that occur in many metric theories of gravitation, but not in general relativity. Other methods have been proposed for doing such experiments—mostly in space—and the case for using the LIGO for this is not as strong as the prime objective of gravitational wave research, but the LIGO facilities can provide a unique opportunity for some secondary experiments such as these. Another area of science which could benefit from the LIGO facilities is geophysical research. Direct measurement of ground strain over the LIGO arms may be a useful byproduct of the installations with minor additions to the instrumentation, and the baselines would be longer than those of existing geophysical interferometers. The operation of a high precision laser gyro in the enhanced facilities may give unique possibilities such as measurement of the rotation rate of the tectonic plates on which the facilities are sited or of improved monitoring of fluctuations in the earth's rotation itself.

The high precision metrology demanded by interferometric gravitational wave research has already led to innovative techniques which are being adopted elsewhere. For example a laser frequency stabilization technique devised by us has proved to be one of the most precise methods of controlling laser frequency; it is now being used in areas of precision spectroscopy and is being developed as a frequency standard for space experiments on gravity wave detection. This frequency stabilization technique is spinoff which has already occurred, but many more of the precise laser beam control, pointing, and aligning techniques being developed in the LIGO project are also likely to have wide application. The development of moderate power, 10 to 100 watt, laser systems with exquisite spectral purity, less than 10^{-4} Hz / $\sqrt{\text{Hz}}$, and amplitude fluctuations at the Poisson limit will find application in communications and precision instrumentation.

Gravitational wave research requires broadband vibration isolation systems operating near the thermal noise limit; the development of these systems has broad application in other areas requiring stability at submicron levels, such as semiconductor chip masking and processing and electron and tunneling microscopy. Members of the LIGO project have been frequently asked to assist in vibration isolation problems. Associated with the vibration isolation technology is our development of economical and precise position sensors using optical fiber and integrated optics technology. These sensors will have application in general instrumentation, precision machine tools and robotics.

There are several areas in which the LIGO project will give impetus to technological innovation and development because of its special needs. The stringent requirements for mirror grinding, polishing and coatings can now be met in industry for the initial LIGO receiver designs but the continuing improvement of receivers will push the development of optics with lower scattering and lower loss.

The data analysis for periodic sources of unknown location and oscillation period is a substantial problem even for supercomputers. The solution of the problem will require both hardware and software innovation.

APPENDICES

Peter R. Saulson

Publications List:

"Search for Luminous Halos of Spiral Galaxies" with B.H. Siebers, Jr., E.D. Loh, and D.T. Wilkinson, *Bull. Am. Astr. Soc.* 12, 490 (1980)

"Large-Scale Anisotropy in the 2.7 K Radiation" with E.S. Cheng and D.T. Wilkinson, *Astrophysical Journal Letters*, 232, L139 (1980)

"A New Limit on the Mass-to-Light Ratio of the Halo of NGC 4565" with S.P. Boughn and M. Seldner, *Astrophysical Journal Letters*, 250, L15 and *Bull. Am. Astr. Soc.* 13, 506 (1981)

"Infrared Photometry of the Halo of M87" with S.P. Boughn, *Astrophysical Journal Letters*, 265, L55 and *Bull. Am. Astr. Soc.* 14, 643 (1983)

"Terrestrial Gravitational Noise on a Gravitational Wave Antenna", *Physical Review D* 15 30, 643 (1984)

"Vibration Isolation for Broad-Band Gravitational Wave Detectors", *Review of Scientific Instruments* 55, 1315 (1984)

"The Smoothness of the 2.2 Micron Background: Constraints on Models of Primeval Galaxies", *Astrophysical Journal* 301, 17 and *Bull. Am. Astr. Soc.* 14, 630 (1986)

"Interferometric Gravitational Wave Detection at MIT" with R. Benford, M. Burka, N. Christensen, M. Eisgruber, P. Fritschel, A. Jeffries, J. Kovalik, P. Linsay, J. Livas, and R. Weiss, 13th Texas Symposium on Relativistic Astrophysics ed. M. Ulmer, Singapore: World Scientific, p. 15 (1986)

"Gravitational Wave Observatories" with A. Jeffries, R. Spero, and M. Zucker, *Scientific American* v.255, no. 6, p. 50 (1987)

"Progress on the MIT 5-Meter Interferometer" with R. Benford, M. Burka, N. Christensen, M. Eisgruber, P. Fritschel, A. Jeffries, J. Kovalik, P. Linsay, J. Livas, and R. Weiss, *International Symposium on Experimental Gravitational Physics*, Guangzhou, China in press (1987)

Reports:

"A Study of a Long Baseline Gravitational Wave Antenna System" with P. Linsay and R. Weiss (1983)

"LIGO Design and Project Plans"
with F. Schutz (1986)

"Final Report of the LIGO Site Selection Working Group" with J. Livas, R. Spero, and K. Thorne (1987)

JULY 1987

PUBLICATIONS

ROBERT SPERO

1. A Method to Limit the Muon Neutrino Mass. H.H. Chen, R. Gutierrez-Lee, S.Y. Nakamura, and R.E. Spero; Phys. Lett. 59B, 274 (1975).
2. Experimental Test of the Gravitational Inverse Square Law at Laboratory Distances. R. Newman, J. Pellam, J. Schultz, and R. Spero; presented at GR8, 8th International Conference on General Relativity and Gravitation, (1977).
3. Test of the Gravitational Inverse Square Force Law at Short Distances. R. Spero, J.K. Hoskins, R. Newman, J. Pellam, and J. Schultz; Bul. APS 24, 579 (1979).
4. Test of the Gravitational Inverse-Square Law at Laboratory Distances. R. Spero, J.K. Hoskins, R. Newman, J. Pellam, and J. Schultz; Phys. Rev. Lett. 44, 1645 (1980).
5. Optical Cavity Laser-Interferometers for Gravitational-Wave Detection. R.W.P. Drever, J. Hough, A.J. Munley, S.-A. Lee, R. Spero, S.E. Whitcomb, H. Ward, G.M. Ford, M. Hereld, N.A. Robertson, I. Kerr, J.R. Pugh, G.P. Newton, B. Meers, E.D. Brooks III, Y. Gursel; Proceedings of the Fifth International Conference on Laser Spectroscopy (VICOLS); June 29 - July 3, 1981, (Jasper, Alberta, Canada 1981).
6. Prospects for Ground Based Detectors of Low Frequency Gravitational Radiation. R. Spero; Science Underground (Los Alamos, 1982), AIP Conference Proceeding Number 96.
7. Gravitational-Wave Detectors Using Laser-Interferometers and Optical Cavities: 1. Ideas, Principles, and Prospects. R.W.P. Drever, A.J. Munley, J. Hough, S.-A. Lee, R. Spero, S.E. Whitcomb, H. Ward, G.M. Ford, M. Hereld, N.A. Robertson, I. Kerr, J.R. Pugh, G.P. Newton, B. Meers, Brooks III, E., Y. Gursel; in Quantum Optics, Experimental Gravity, and Measurement Theory (eds. Pierre Meystere and Marlan O. Scully), 503-514, (Plenum Publishing, 1983)
8. Gravitational-Wave Detectors Using Laser-Interferometers and Optical Cavities: 2. Some practical aspects and results. J. Hough, R.W.P. Drever, A.J. Munley, S.-A. Lee, R. Spero, S.E. Whitcomb, J. Pugh, G. Newton, B. Meers, Brooks III, E., Y. Gursel; in Quantum Optics, Experimental Gravity, and Measurement Theory (eds. Pierre Meystere and Marlan O. Scully), 515-524, (Plenum Publishing, 1983)
9. Laser-Interferometer Experiments at Caltech. S. Whitcomb, D.Z. Anderson, R.W.P. Drever, Y. Gursel, M. Hereld, R. Spero, Third Marcel Grossman Conference on General Relativity, Shanghai, China 1982, Ed. Hu Ning (Science Press and North-Holland Publishing Co., 1983) pp. 1399

10. Developments in Laser-Interferometer Gravitational-Wave Detectors. R.W.P. Drever, S. Hoggan, B. Meers, A. Munley, G. Newton, H. Ward, D.Z. Anderson, Y. Gursel, M. Hereld, R. Spero, S. Whitcomb, Third Marcel Grossman Conference on General Relativity, Shanghai, China 1982, Ed. Hu Ning (Science Press and North-Holland Publishing Co., 1983) pp. 739-753
11. The Caltech Gravitational-Wave Detector. R. Spero, D.Z. Anderson, R.W.P. Drever, Y. Gursel, G. Gutt, M. Hereld, J. Kaufman, S.E. Whitcomb; in "General Relativity and Gravitation", 10th International Conference on General Relativity and Gravitation, Padua, July 1983. eds. B. Bertotti, F. de Felice, and A. Pascolini; (Reidel Pub. Co. 1984)
12. Experimental Tests of the Gravitational Inverse-Square Law for Mass Separations from 2 to 105 cm. J.K. Hoskins, R.D. Newman, R. Spero, J. Schultz, in The American Physical Society, Physical Review D, Volume 32, Number 12 (December 1985)
13. The Caltech Laser-Interferometric Gravitational-Wave Detector. R. Spero; in Proceedings of the Fourth Marcel Grossmann Meeting on General Relativity, R. Ruffini (ed.) (Elsevier Science Publishers B.V., 1986)
14. Gravitational-Wave Observatories. A. Jeffries, P. Saulson, R. Spero, M. Zucker; in Scientific American, Volume 255, Number 6, (June, 1987)

TECHNICAL PUBLICATIONS/PRESENTATIONS---BOUDE C. MOORE

1. 'The Pulse Technique'. Flight Lines. July 1952, p6-7
2. 'Flight Test Development of Autopilots'. Control Engineering, August 1953, p 85-90
3. 'Estimate Resonant Frequency of Hydraulic Actuators'. Control Engr, July 1957 p 73-74
also Product Engineering, Sept 1958, p JS
4. 'Automatic Testing with a Digital Computer'. Waveguide, v II, #4, Dec 1959, p 16-17
5. 'Automation Promises Better Testing'. Missiles and Rockets, v 7 #27, p 40-43, Dec 5, 1960
6. 'Effect of Gas Condensate on Cryopumping'. Transactions 9th National Vacuum Symposium, p 312-5, 1962
7. 'In-Situ Calibration of Vacuum Gages'. Presented to 1st International Congress on Vacuum Techniques in Space Research, Paris, France, June 29--July 4, 1964
8. 'Measurement of Vacuum in Non-Uniform Temperature Environment'. JVST, v 1, p 10-16
9. 'Vacuum Sealing Rough Surfaces'. JVST, v 2, p 160, 1965
10. 'Advantages of a Spherical Geometry in Vacuum Measurements'. JVST, v 2, p 211-213, 1965
11. 'Effect of Localized Gas Densities on Vacuum Ionization Gages (with L.E. Bergquist, R.G. Camarillo, & R.W. Larson) Trans 3rd Intl Vacuum Congress, Stuttgart, Germany, v 2, p 251-4, 1965
12. 'The Contribution of Cryogenics to Space Simulation'. presented to So Calif Chapter, Cryogenic Soc Am, Jul 1966
13. 'A Cryogenic Low Pressure Seal (with L. E. Bergquist & F. R. Clements). JVST v 4, p 45-6, 1967
14. 'Causes and Consequences of Non-Uniform Gas Distributions in Vacuum Systems'. JVST, v 6, p 246-254, 1969 (Invited Paper)
15. 'Simulating the Space Environment'. Science Journal, Feb 1967, p 41-46
16. 'Spherical Chamber for Calibrating Vacuum Gauges'. U.S. Patent #3,367,149, granted Feb 6, 1968
17. 'The Problem of Qualifying Movable Mechanisms for Space Operations (with L.C. King), presented to 1st Annual Symposium, Southwest Section, American Vacuum Society, May 1, 1968, Anaheim, CA
18. 'Management of Laboratory Automation'. presented to Test Laboratory Managers Working Group, Los Angeles, CA, Jan 1971
19. 'Test Laboratory Management Despite Risks-or, 'The Best Laid Schemes...'. Trans 17th Annual Mtg IES, P 408-411, 1971
20. 'Gas Flux Patterns in Cylindrical Vacuum Systems'. JVST, v 9, p 1090-99, 1972
21. 'Sweet Helium Leak Detection'. (with R.G. Camarillo). JVST, v 10, p 404, 1973
22. 'Encouraging Creativity in Test Laboratory Organizations'. (with P. Trov., Proceedings IES, 18th Annual Mtg, 1973
23. 'Contamination Control in Space Simulation Chambers'. 7th Conference on Space Simulation, NASA P-336, p 265-279, 1973
also presented to SWSG Symposium, Hawthorne, CA, June 1973
24. 'Cost Reduction in Test Laboratory Operation'. presented to Test Laboratory Managers Working Group, Sept 1973
25. 'Cost Effective Tests-or 'More Bang for the Buck'. Proceeding 20th Annual Mtg IES, p 373-?. 1974
26. 'Space Simulation'. presented to AIAA Arrowhead Section, Oct 1975
27. 'Tracer Slug Leak Detection'. (with J.A. Walker) JVST, v 16, p 598-700, 1979
28. 'Molecular Wake Shields of Various Shapes'. JVST, v 16, p 946-50, 1979
29. 'Proposed Method for Degassing Metals for Extreme Low Pressures'. JVST, v 17, p 930-7, 1980
30. 'Degassing for Space Vacuum Research'. TIE, v 12 # 6, p 4, 1981
31. 'Cryopump for Large Pulses of Hydrogen'. (with R.G. Camarillo & J.T. Morrow). 12th Space Simulation Conference, NASA Conf Publ 2229, p 87-112, 1982
32. 'Contamination and Thermal Control' (with W. Olson, R. Fader). AIAA/NASA Space Systems Technology Conf, June 1984
To be published in Aerospace America

Livas publications:

Livas, J., Benford, R., Dewey, D., Jeffries, A., Linsay, P., Saulson, P., Shoemaker, D., Weiss, R. *The M.I.T. Prototype Gravitational Wave Detector*, In *Proceedings of the Fourth Marcel Grossman Meeting on General Relativity*, ed. R. Ruffini, p. 591, (1985).

Livas, J. *Broadband Search Techniques for Periodic Sources of Gravitational Radiation*. In *Proceedings of the 1987 NATO Advanced Research Workshop on Gravitational Wave Data Analysis*, ed B. Schutz (1987).

PAUL S. LINSAY PUBLICATIONS

NONLINEAR DYNAMICS:

Deviations from Universality in the Transition from Quasiperiodicity to Chaos, Andrew Cumming and Paul S. Linsay, *Physical Review Letters*, 59, 1633(1987)

The Structure of Chaotic Behavior in a PN Junction Oscillator, Paul S. Linsay, *Perspectives in Non-linear Dynamics*, World Scientific Publishing Co., 1986, Singapore

Approximate Scaling of Period Doubling Windows, P. S. Linsay, *Physics Letters*, 108A, 431(1985)

The Self-replicating Attractor of a Driven Semiconductor Oscillator, S.D. Brorson, D. Dewey, and P.S. Linsay, *Physical Review A* 28, 1201(1983)

Period Doubling and Chaotic Behavior in a Driven Anharmonic Oscillator, P.S. Linsay, *Physical Review Letters* 47, 1349(1981)

GENERAL RELATIVITY, INTERFEROMETRIC GRAVITY ANTENNA:

A Low Noise RF Capacitance Bridge, P.S. Linsay, and D.H. Shoemaker, *Reviews of Scientific Instruments* 1014, 53(1982)

Response of a Free Mass Interferometer Antenna to Gravitational Waves, Y. Gursel, P.S. Linsay, P. Saulson, R. Spero, R. Weiss, and S. Whitcomb, in preparation

HIGH ENERGY PHYSICS:

Observation of Prompt Like-Sign Dimuon Production in Neutrino Reactions, K. Nishikawa, D. Buchholz, B.C. Barish, J.F. Bartlett, R. Blair, Y. Chu, J. Lee, P.S. Linsay, J. Ludwig, R. Messner, P. Mine, F.J. Sciulli, M. Shaevitz, E. Siskind, D. Edwards, H. Edwards, H.E. Fisk, Y. Fukushima, G. Krafczyk, D. Nease, A. Bodek, W. Marsh, and O. Fackler, *Physical Review Letters* 46, 1555(1981)

Flux Normalized Charged-Current Neutrino Cross Sections up to Neutrino Energies of 260 GeV, B.C. Barish, R. Blair, J. Lee, P. Linsay, J. Ludwig, R. Messner, F. Sciulli, M. Shaevitz, F. Bartlett, D. Edwards, H. Edwards, E. Fisk, G. Krafczyk, Y. Fukushima, Q. Kerns, T. Kondo, D. Nease, S. Segler, D. Theriot, A. Bodek, W. Marsh, O. Fackler, and K. Jenkins, *Proceedings of the Neutrino '79 International Conference*, Bergen, Norway, June 18-22 1979

Density Dependence of Dimuon Rates in the CFNRR Experiment, B.C. Barish, J.F. Bartlett, Y. K. Chu, K. Kleinknecht, J. Lee, P.S. Linsay, J. Ludwig, R. Messner, P. Mine, F.J. Sciulli, M. Shaevitz, E. Siskind, D. Edwards, H. Edwards, H.E. Fisk, G. Krafczyk, D. Nease, D. Buchholz, K. Nishikawa, A. Bodek, W. Marsh, and O. Fackler;

Proceedings of the International Conference on Neutrino Physics and Neutrino Astrophysics, Purdue University, April 1978

Very Large Area Scintillation Counters for Hadron Calorimetry B.C. Barish, A. Bodek, Y.K. Chu, K. Kleinknecht, J. Lee, P.S. Linsay J. Ludwig, F. Sciulli, and M. Shaevitz, IEEE Transactions in Nuclear Science, NS-25, p. 532, talk presented at the 1977 Nuclear Science Symposium, San Francisco, California, Oct. 1977

Measurement of the Decay Rate for the Rare Process $K_L \rightarrow \mu^+ \mu^-$. Shochet, M.J., P.S. Linsay, C. Grosso-Pilcher, H.J. Frisch, R. Devoe, J.W. Cronin, and D.R. Moffett, Physical Review Letters 39, 59(1977)

Measurement of the Branching Ratio $\Gamma(K_L \rightarrow \pi^+ \pi^-) / \Gamma(K_L \rightarrow \text{all})$, Devoe, R., J.W. Cronin, H.J. Frisch, C. Grosso-Pilcher, P.S. Linsay, M.J. Shochet, and D.R. Moffett, Physical Review D16,565(1977)

Andrew D. Jeffries

Publications List:

"Gravitational Wave Observatories", A.D. Jeffries, P.R. Saulson, R.E. Spero, M.E. Zucker. Scientific American, June, 1987, Vol 256, No 6

"The MIT Prototype Gravitational Wave Detector", J. Livas, R. Benford, D. Dewey, A. Jeffries, P. Linsay, P. Saulson, D. Shoemaker, R. Weiss. Proceedings of the Fourth Marcel Grossman Meeting on General Relativity, Elsevier, Amsterdam, 1986

"Monolithic Silicon Bolometers", P.M. Downey, A.D. Jeffries, S.S. Meyer, R. Weiss, and F.J. Backner, J.P. Donnelly, W.T. Lindley, R.W. Mountian, D.J. Silversmith. Applied Optics, Vol 23 Pg 910, 1984

"A Search for the Sunyaev-Zel'dovich Effect at Millimeter Wavelengths", S.S. Meyer, A.D. Jeffries, R. Weiss. The Astrophysical Journal, Letters 271:1

"Laser Systems for Interferometric Gravitational Wave Detectors" Fourth Marcel Grossman Meeting on General Relativity, Stockholm. Paper No 490

"A Search for Inverse Compton Scattering of the Cosmic Background (Zel'dovich Effect)", Talk given at : NASA Ames Research Center Sept, 1982; American Astronomical Society 161st meeting Jan, 1983

- 10) R. W. P. Drever, S. Hoggan, J. P. Hough, B. J. Meers, A. J. Munley, G. P. Newton, H. Ward, D. Z. Anderson, Y. Gursel, M. Hereld, R. E. Spero, S. E. Whitcomb; Developments in Laser Interferometer Gravitational Wave Detectors; in Proceedings of the Third Marcel Grossman Meeting on General Relativity, Shanghai (in press)
- 11) R. Spero, D. Z. Anderson, R. W. P. Drever, Y. Gursel, G. Gutt, M. Hereld, J. Kaufman, S. E. Whitcomb; The Caltech Gravitational Wave Detector; in Proceedings of the Tenth International Conference on General Relativity and Gravitation, eds. B. Bertotti, F. deFelice, A. Pascolini (Congiglio Nazionale Delle Ricerche - Roma), 1983.
- 12) James H. Applegate, Michael R. Douglas, Yekta Gursel, Peter Hunter, Charles L. Seitz and Gerald Jay Sussman; A Digital Orrery; IEEE Transactions on Computers, Volume C-34, Number 9, 822 (1985)
- 13) James H. Applegate, Michael R. Douglas, Yekta Gursel, Gerald Jay Sussman and Jack Wisdom; The Outer Solar System for 110 Million Years; accepted for publication in the Astronomical Journal, 1986.

Y. GURSEL

PUBLICATIONS

- 1) Y. Gursel, U. D. Sandberg, I. D. Novikov, A. A. Starobinsky; Evolution of scalar perturbations near the Cauchy horizon of a charged black hole; in Phys. Rev. D, Volume 19, Number 2, 413 (1979)
- 2) Y. Gursel, I. D. Novikov, U. D. Sandberg, A. A. Starobinsky; Final state of the evolution of the interior of a charged black hole; in Phys. Rev. D Volume 20, Number 6, 1260 (1979)
- 3) D. Macdonald and Y. Gursel; Solving Soma Cube and Polyomino Puzzles; in BYTE, Volume 4, Number 11, 26 (1979)
- 4) R.W.P. Drever, J. Hough, A. J. Munley, S-A. Lee, R. Spero, S. E. Whitcomb H. Ward, G. M. Ford, M. Herald, N. A. Robertson, I. Kerr, J. R. Pugh, G. P. Newton, B. Meers, E. D. Brooks III, Y. Gursel; Optical Cavity Laser Interferometers for Gravitational Wave Detection; in the Proceeding of the Fifth International Conference on Laser Spectroscopy, Springer Verlag. Page 33 (1981)
- 5) Y. Gursel; Multipole Moments in General Relativity: The Equivalence of the Geroch-Hansen Formulation and the Thorne Formulation; in General Relativity and Gravitation, Volume 15, Number 8, 737 (1983)
- 6) K. S. Thorne and Y. Gursel; The Free Precession of Slowly Rotating Neutron Stars: Rigid Body Motion in General Relativity; in Monthly Notices of the Royal Astronomical Society, Volume 205, 809 (1983)
- 7) R.W.P. Drever, J. Hough, A. J. Munley, S-A. Lee, R. Spero, S. E. Whitcomb H. Ward, G. M. Ford, M. Herald, N. A. Robertson, I. Kerr, J. R. Pugh, G. P. Newton, B. Meers, E. D. Brooks III, Y. Gursel; Gravitational Wave Detectors Using Laser Interferometers and Optical Cavities: Ideas, Principles and Prospects; in Quantum Optics, Experimental Gravity, and Measurement, eds. Pierre Meystre and Marlan O. Scully, Plenum Publishing Corporation, Pages 503-504 (1983)
- 8) R.W.P. Drever, J. Hough, A. J. Munley, S-A. Lee, R. Spero, S. E. Whitcomb H. Ward, G. M. Ford, M. Herald, N. A. Robertson, I. Kerr, J. R. Pugh, G. P. Newton, B. Meers, E. D. Brooks III, Y. Gursel; Gravitational Wave Detectors Using Laser Interferometers and Optical Cavities - 2: Some Practical Aspects and Results; in Quantum Optics, Experimental Gravity, a Measurement, eds. Pierre Meystre and Marlan O. Scully, Plenum Publishing Corporation, Pages 505-514 (1983)
- 9) S. E. Whitcomb, D. Z. Anderson, R. W. P. Drever, Y. Gursel, M. Herald, R. Spero; Laser Interferometer Experiments at Caltech; in Proceedings of the Third Marcel Grossman Meeting on General Relativity; Shaghai (in press)

11. Turkevich, A. L.; E. J. Franzgrote; J. H. Patterson; Chemical Analysis of the Moon at the Surveyor VII Landing Site: Preliminary Results, Science, Vol. 162, pp. 117-118, October, 1968.
12. Turkevich, A. L.; J. H. Patterson; E. J. Franzgrote; The Chemical Analysis of the Lunar Surface, American Scientist, Vol. 56, No. 4, pp. 312-343, 1969.
13. Turkevich, A. L.; W. A. Anderson; T. E. Economou; E. J. Franzgrote; et. al.; The Alpha-Scattering Chemical Analysis Experiment on the Surveyor Lunar Missions, NASA SP-184, pp. 271-350, 1969.
14. Turkevich, A. L.; E. J. Franzgrote; J. H. Patterson; Chemical Composition of the Lunar Surface in Mare Tranquillitatis, Science, Vol. 165, pp. 277-279, July 1969.
15. Patterson, J. H.; E. J. Franzgrote; et. al.; Alpha-Scattering Experiment on Surveyor 7: Comparison with Surveyors 5 and 6, J. Geophys. Res., Vol. 74, No. 25, pp. 6120-6148, November 1969.
16. Franzgrote, Ernest J.; et. al; Chemical Composition of the Lunar Surface in Sinus Medii, Science, Vol. 167, pp. 376-379, January 1970.
17. Franzgrote, E. J.; Geochemistry of the Moon, 1970 McGraw-Hill Yearbook of Science and Technology, pp. 257-259, February, 1970
18. Patterson, J. H.; A. L. Turkevich; E. J. Franzgrote; Chemical Analysis of the Lunar Surface in the Surveyor Program -- Summary, Radio Science, Vol. 5, No. 2, pp. 181-183, February 1970.
19. Turkevich, A. L.; J. H. Patterson; E. J. Franzgrote; et. al.; Alpha Radioactivity of the Lunar Surface at the Surveyor V, VI, and VII Landing Sites, Science, Vol. 167, pp. 1722-1724, March 1970.
20. Patterson, J. H.; A. L. Turkevich; E. J. Franzgrote; et. al.; Chemical Composition of the Lunar Surface in a Terra Region Near the Crater Tycho, Science, Vol. 168, pp. 825-828, May 1970.
21. Economou, T. E.; A. L. Turkevich; K. P. Sowinski; J. H. Patterson; E. J. Franzgrote; The Alpha-Scattering Technique of Chemical Analysis, J. Geophys. Res., Vol. 75, No. 32, pp. 6514-6523, November 1970.

PUBLICATIONS OF ERNEST J. FRANZGROTE

1. Patterson, James H.; Anthony L. Turkevich; Ernest Franzgrote; Chemical Analysis of Surfaces Using Alpha Particles, J. Geophys. Res., Vol. 70, No. 6, pp. 1311-1327, March 1965.
2. Patterson, J. H.; A. L. Turkevich; E. Franzgrote; Analysis of Light Elements in Surfaces by Alpha-Particle Scattering, Radioisotope Instruments in Industry and Geophysics, Vol. 1, pp. 337-345, International Atomic Energy Agency, Vienna, 1966.
3. Turkevich, A.; E. Franzgrote; et. al.; Instrument for Lunar Surface Chemical Analysis, The Review of Scientific Instruments, Vol. 37, No. 12, pp. 1681-1686, December 1966.
4. Turkevich, A. L.; E. Franzgrote; et. al.; Chemical Analysis Experiment for the Surveyor Lunar Mission, J. Geophys. Res., Vol. 72, No. 2, pp. 831-839, January 1967
5. Turkevich, A. L.; E. J. Franzgrote; J. H. Patterson; Chemical Analysis of the Moon at the Surveyor V Landing Site, Science, Vol. 158, pp. 635-637, November 1967.
6. Turkevich, A. L.; E. J. Franzgrote; J. H. Patterson; Chemical Analysis of the Moon at Surveyor V Landing Site: Preliminary Results, NASA SP-163, pp. 107-132, December 1967.
7. Turkevich, A. L.; E. J. Franzgrote; J. H. Patterson; Study of Contamination of Surveyor V Landing Site by Main Retro Exhaust, Appendix A, NASA SP-163, pp. 157-158, December 1967.
8. Turkevich, A. L.; E. J. Franzgrote; J. H. Patterson; Chemical Analysis of the Moon at Surveyor VI Landing Site: Preliminary Results, NASA SP-166, pp. 109-132, March 1968.
9. Franzgrote, E. J.; et. al.; Chemical Analysis of the Moon at the Surveyor VII Landing Site: Preliminary Results, NASA SP-173, pp. 207-232, May 1968.
10. Turkevich, A. L.; J. H. Patterson; E. J. Franzgrote; Chemical Analysis of the Moon at the Surveyor VI Landing Site: Preliminary Results, Science, Vol. 160, pp. 1108-1110, June 1968.

E. Michael Burka

List of Publications

E. Michael Burka, *Design considerations in large interferometers*, poster presentation at the 11th International Conference on General Relativity and Gravitation, Stockholm, Sweden, July 6-12, 1986

B. Barnett, M. Burka, C. Y. Chien, D. Christian, W. Koska, L. Madansky, S. Wagner, and N. C. Yang, *Study of the Reaction $\bar{p}p \rightarrow K^+K^-\pi^+\pi^-$ at 8.9 GeV/c*, Physical Review D, v.30 n.9 (1 November 1984), p. 1871

B. Barnett, D. Blockus, M. Burka, C. Y. Chien, D. Christian, W. Koska, L. Madansky, C. May, Y. T. Oh, A. Pevsner, S. Wagner, C. Woody, and N. C. Yang, *Limits on baryonium production in $\bar{p}p$ interactions at 8.9 and 19.0 GeV/c*, Physical Review D, v.27 n.3 (1 February 1983), p. 493

B. Barnett, D. Blockus, M. Burka, C. Y. Chien, D. Christian, W. Koska, L. Madansky, C. May, Y. T. Oh, A. Pevsner, S. Wagner, C. Woody, and N. C. Yang, *Search for the $\rho^0\rho^0$ enhancement near 1700 MeV/c² in the reaction $\bar{p}p \rightarrow 3\pi^+3\pi^-\pi^0$ at 8.9 GeV/c*, Physics Letters, v.120B n.4,5,6 (13 January 1983) p. 455

Richard Benford

Publications List:

Articles Submitted for Publication:

"Measurements of the Anisotropy of the Cosmic Background Radiation and Diffuse Galactic Emission at Millimeter and Submillimeter Wavelengths," with M. Halpern, R. Benford, S. Meyer, D. Muehlner

WILLIAM E. ALTHOUSE

Publications:

"A Solar and Galactic Cosmic Ray Satellite Experiment" (with E.C. Stone, R.E. Vogt, and T.H. Harrington), IEEE Trans. on Nuclear Science, **NS-15**, 229 (1968).

"A Cosmic Ray Isotope Spectrometer" (with A.C. Cummings, T.L. Garrard, R.A. Mewaldt, E.C. Stone, and R.E. Vogt), IEEE Trans. on Geoscience Electronics, **GE-16**, 204 (1978)

"The Voyager Cosmic Ray Experiment" (with D.E. Stilwell, W.D. Davis, R.M. Joyce, F.B. McDonald, J.H. Trainor, A.C. Cummings, T.L. Garrard, E.C. Stone, and R.E. Vogt), IEEE Trans. on Nuclear Science, **NS-26**, 513 (1979)

"A Balloon-Borne Imaging Gamma-Ray Telescope" (with W.R. Cook, A.C. Cummings, M.H. Finger, T.A. Prince, S.M. Schindler, C.H. Starr, and E.C. Stone), **Conf. Papers**, 19th International Cosmic Ray Conference, La Jolla, CA, **3**, 299 (1985)

"Balloon-Borne Video Cassette Recorders for Digital Data Storage" (with W.R. Cook), *ibid* **3**, 395 (1985)

"First Flight of a New Balloon-Borne Gamma-Ray Imaging Telescope" (with W.R. Cook, A.C. Cummings, M.H. Finger, D.M. Palmer, T.A. Prince, S.M. Schindler, C.H. Starr, and E.C. Stone), **Conf. Papers**, 20th International Cosmic Ray Conference, Moscow, USSR (1987)

11. A. Abramovici, Z. Vager, M. Weksler
Experimental test of a prototype active cavity gravitational wave detector
Proceedings of the Fourth Marcel Grossmann Meeting on General Relativity and
Gravitation, Rome, 17-21 June 1985
R. Ruffini ed., Elsevier Publishers B. V. 1986
12. A. Abramovici
Interferometer performance in the presence of losses
Optics Communications **57**, 1-2 (1986)
13. A. Abramovici, Z. Vager
Comparison between active and passive interferometers
Physical Review A **33**, 3181-3184 (1986)
14. A. Abramovici, Z. Vager
A test of Newton's second law at small accelerations
Physical Review D **34**, 3240-3241 (1986)
15. A. Abramovici
Minimal Nd:YAP laser configuration with single frequency output
Optics Communications **61**, 401-405 (1987)
16. A. Čadež, A. Abramovici
Measuring high mechanical quality factors of bodies made of bare insulating materials
J. Phys. E: Scientific Instruments, in press

October 1987

Alex Abramovici

List of publications

1. E. Hegedus, A. Abramovici
Ueber die Abhaengigkeit der Barionenmassen vom Bahndrehimpuls
Ann. Univ. Timisoara, Math.-Phys. **6**, 173-180 (1968)
2. E. Hegedus, A. Abramovici
On completing the SU(3) baryon mass formula with the J^P dependence
Ann. Univ. Timisoara, Math.-Phys. **6**, 167-171 (1968)
3. A. Abramovici, L. Vekas
Statistical model calculation of the branching ratios of N^* (1470)
Acta Phys. Hungarica **26**, 417-419 (1969)
4. E. Hegedus, A. Abramovici, L. Vekas
About the existence of an I=5/2 isobar at 1470 MeV
Z. Physik **225**, 121-124 (1969)
5. A. Abramovici, E. Hegedus, L. Vekas
About the possible existence of I=5/2 nucleon resonances
Z. Physik **255**, 446-449 (1972)
6. A. Abramovici
Comment on the $u=-0.15$ GeV² dip mechanism in π^+p elastic scattering
Univ. Timisoara preprint FT4 (1975), unpublished
7. L. Vekas, A. Abramovici
Light and heavy constituents in a lattice algebra
Acta Phys. Polonica **B8**, 937-944 (1977)
8. E. Hegedus, A. Abramovici, L. Vekas
Baryon spectroscopy and exotics
Univ. Timisoara preprint FT3 (1980), unpublished
9. A. Abramovici
FESR analysis of the dip mechanism in backward $K^-p \rightarrow \Lambda\pi^0$ scattering
Acta Phys. Polonica **B11**, 201-208 (1980)
10. A. Abramovici, Z. Vager, M. Weksler
Experimental test of a prototype gravitational radiation detector employing an active cavity laser sensor
J. Phys. E: Scientific Instruments **19**, 182-188 (1986)

PUBLICATIONS

16. "The Isotopes of H and He in Solar Cosmic Rays", (with T. L. Garrard and E. C. Stone), High Energy Phenomena on the Sun Symposium Proceedings, edited by R. Ramaty and R.G. Stone, GSFC Preprint X-693-73-193, 341 (1973).
17. "The Energy Spectrum of 0.16 to 3 MeV Electrons during Solar Quiet Times", (with G. J. Hurford, R. A. Mewaldt and E. C. Stone) Conf. Papers, 13th Int. Cosmic Ray Conf., Denver, 1, 324 (1973)
18. "Observations of the Ratio of Low-Energy Cosmic-Ray Positrons and Electrons during Solar Quiet Times", (with G. J. Hurford, R. A. Mewaldt, and E. C. Stone), ibid, 1, 330 (1973).
19. "Observations of Low Energy Hydrogen and Helium Isotopes during Solar Quiet Times", (with G. J. Hurford, R. A. Mewaldt, and E. C. Stone), ibid, 1, 93 (1973).
20. "Measurements of the Cosmic-Ray Be/B Ratio and the Age of Cosmic Rays", (with J. W. Brown and E. C. Stone), ibid, 1, 484 (1973).
21. "The Elemental Abundance Ratios of Interstellar Secondary and Primary Cosmic Rays", (with J. W. Brown and E. C. Stone), ibid, 1, 556 (1973).
22. "Interstellar Electron Spectrum from the Galactic Non-Thermal Radio Emission", (with A. C. Cummings and E. C. Stone), ibid, 1, 335 (1973).
23. "Evidence for Primary Interstellar Cosmic-Ray Electrons", (with A. C. Cummings and E. C. Stone), ibid, 1, 340 (1973).
24. "Interplanetary Diffusion Coefficients for Cosmic Rays", (with A. C. Cummings and E. C. Stone), ibid, 2, 772 (1973).
25. "Analytic Approximations in the Study of the Solar Modulation of Electrons", (with A. C. Cummings and E. C. Stone), ibid, 2, 765 (1973).
26. "Solar Modulation of Cosmic-Ray Protons and He Nuclei", (with T. L. Garrard and E. C. Stone), ibid, 2, 732 (1973).
27. "Relation of the Radial Gradient of Cosmic-Ray Protons to the Size of the Solar Modulation Region", (with T. L. Garrard and E. C. Stone), ibid, 2, 1336 (1973).
28. "Measurements of the Flux of Low-Energy Solar-Flare Positrons", (with G. J. Hurford, R. A. Mewaldt and E. C. Stone), ibid, 2, 1613 (1973).
29. "The Energy Spectrum of 0.16 to 2 MeV Electrons During Solar Quiet Times", (with G. J. Hurford, R. A. Mewaldt and E. C. Stone), Ap.J., 192, 541 (1974).
30. "Particles and Fields in the Outer Solar System", (with G. L. Siscoe), Icarus, 24, 333 (1975).

ROCHUS E. VOGT

PUBLICATIONS IN HIGH ENERGY ASTROPHYSICS

1. "Electrons in the Primary Cosmic Radiation", (with P. Meyer), Phys. Rev. Letters 6, 193 (1961).
2. "The Primary Cosmic-Ray Electron Flux during a Forbush-Type Decrease", (with P. Meyer), J. Geophys. Res. 66, 3950 (1961).
3. "Flux and Energy Spectra of Primary Cosmic Ray Protons from 70 to 400 MeV"; J. Phys. Soc. Japan, 17, SA-11, 436 (1962).
4. "Some Properties of Primary Cosmic Ray Electrons", (with P. Meyer), J. Phys. Soc. Japan, 17, SA-III, 5 (1962).
5. "Primary Cosmic-Ray and Solar Protons", Phys. Rev. 125, 366 (1962).
6. "High Energy Electrons of Solar Origin", (with P. Meyer), Phys. Rev. Letters 8, 387 (1962).
7. "Primary Cosmic-Ray and Solar Protons II", (with P. Meyer), Phys. Rev. 129, 2275 (1963).
8. "Changes in the Primary Cosmic Ray Proton Spectrum in 1962 and 1963", (with P. Meyer), Proc. 8th Int. Conf. on Cosmic Rays, 3, 49 (1963).
9. "A Solar and Galactic Cosmic Ray Satellite Experiment", (with W. E. Althouse, T. H. Harrington, and E. C. Stone), IEEE Trans., NS-15, 229 (1968).
10. "Long-Term Variations of the Primary Cosmic-Ray Electron Component", (with J. L'Heureux, P. Meyer, and S. D. Verma), Can. J. Phys. 46, 896 (1968).
11. "Flux of Cosmic-Ray Electrons between 17 and 63 MeV", (with M. H. Israel), Phys. Rev. Letters 20, 1053 (1968).
12. "Cosmic-Ray Negatron and Positron Spectra between 12 and 220 MeV", (with K. P. Beuermann, C. J. Rice and E. C. Stone), Phys. Rev. Letters 22, 412 (1969).
13. "Characteristics of the Diurnally Varying Electron Flux near the Polar Cap", (with M. H. Israel), J. Geophys. Res. 74, 4714 (1969).
14. "Cosmic-Ray Negatron and Positron Spectra Observed near Fort Churchill in 1968", (with K. P. Beuermann, C. J. Rice, and E. C. Stone), Acta Physica Academiae Scientiarum Hungaricae 29, Suppl. 1, 173 (1970).
15. "Interplanetary Deceleration of Solar Cosmic Rays", (with S. S. Murray and E. C. Stone), Phys. Rev. Letters, 26, 663 (1971).

45. "Neutral Particle Background in Cosmic Ray Telescopes Composed of Silicon Solid State Detectors", (with R. A. Mewaldt and E. C. Stone), Space Science Instrumentation, 3, 231, (1977).
46. "Cosmic Ray Investigation for the Voyager Missions; Energetic Particle Studies in the Outer Heliosphere - and Beyond", (with E. C. Stone, F. B. McDonald, B. J. Teegarden, J. H. Trainor, J. R. Jokipii, and W. R. Webber), Space Science Review, 21, 355, (1977).
47. "Simultaneous Observations of Cosmic Ray Particles in Corotating Interplanetary Structures at Different Solar Distances between 0.3 and 1.0 AU from HELIOS 1 and 2 and IMP 7 and 8", (with H. Kunow, G. Wibberenz, G. Green, R. Müller-Mellin, R. Witte, E. Hemp, E.C. Stone and R. Mewaldt), 15th International Cosmic Ray Conference Plovdiv, Bulgaria, Conf. Papers 3, 227, (1977).
48. "A Cosmic Ray Isotope Spectrometer", (with W.E. Althouse, A.C. Cummings, T.L. Garrard, R.A. Mewaldt and E.C. Stone), IEEE Trans. on Geoscience Electronics GE-16, 204, (1978).
49. "The Radial Diffusion Coefficient of 1.3 - 2.3 MeV Protons in Recurrent Proton Streams", (with R.A. Mewaldt and E.C. Stone), Geophys. Res. Ltrs. 5, 965, (1978).
50. "Characteristics of the Spectra of Protons and Alpha Particles in Recurrent Events at 1 AU", (with R.A. Mewaldt and E.C. Stone), Geophys. Res. Ltrs. 6, 589, (1979).
51. "The Isotopic Composition of Solar Flare Accelerated Neon", (with R.A. Mewaldt, J.D. Spalding and E.C. Stone), Ap.J. (Letters) 231, L97, (1979).
52. "The Voyager Cosmic Ray Experiment", (with D.E. Stilwell, W.D. Davis, R.M. Joyce, F.B. McDonald, J.H. Trainor, W.E. Althouse, A.C. Cummings, T.L. Garrard and E.C. Stone), IEEE Trans. on Nuclear Science, NS-26, 513, (1979).
53. "Voyager 1: Energetic Ions and Electrons in the Jovian Magnetosphere", (with W.R. Cook, A.C. Cummings, T.L. Garrard, N. Gehrels, E.C. Stone, J.H. Trainor, A.W. Schardt, T. Conlon, N. Lal and F.B. McDonald), Science 204, 1003, (1979).
54. "Voyager 2: Energetic Ions and Electrons in the Jovian Magnetosphere", (with A.C. Cummings, T.L. Garrard, N. Gehrels, E.C. Stone, J.H. Trainor, A.W. Schardt, T.F. Conlon and F.B. McDonald), Science 206, 984, (1979).
55. "Satellite Measurements of the Isotopic Composition of Galactic Cosmic Rays", (with R.A. Mewaldt, J.D. Spalding and E.C. Stone), 16th International Cosmic Ray Conference Kyoto, Japan, Conf. Papers 12, 86, (1979).
56. "The Elemental Composition of Quiet Time Low Energy Cosmic Rays Measured on the Voyager Spacecraft", (with W.R. Webber and E.C. Stone), ibid 5, 357, (1979).
57. "Elemental Composition of Solar Energetic Particles in 1977 and 1978", (with W.R. Cook, E.C. Stone, J.H. Trainor and W.R. Webber), ibid 12, 265, (1979).

31. "The Isotopic Composition of Hydrogen and Helium in Low Energy Cosmic Rays", (with R. A. Mewaldt and E. C. Stone), 14th International Cosmic Ray Conf. Munich, Germany, Conf. Papers, 1, 306 (1975).
32. "Isotopic Composition of the Anomalous Low Energy Cosmic Ray Nitrogen and Oxygen", (with R. A. Mewaldt, E. C. Stone and S. B. Vidor), ibid, 1, 349 (1975).
33. "The Elemental Composition of 4-30 MeV/nuc Cosmic Ray Nuclei with $1 \leq Z \leq 8$ ", (with R. A. Mewaldt, E. C. Stone and S. B. Vidor), ibid, 2, 798 (1975).
34. "Implications of Time Variations for the Origin of Low Energy Cosmic Ray Nitrogen and Oxygen Nuclei", (with R. A. Mewaldt and E. C. Stone), ibid, 2, 804 (1975).
35. "Observations of Hydrogen and Helium Isotopes in Solar Cosmic Rays", (with G. J. Hurford and E. C. Stone), ibid, 5, 1624 (1975).
36. "A Search for Solar Flare Positrons", (with R. A. Mewaldt and E. C. Stone), ibid, 5, 1668 (1975).
37. "Observations of Low Energy Interplanetary Electrons", (with R. A. Mewaldt and E. C. Stone), ibid, 2, 758 (1975).
38. "The Quiet Time Flux of 0.16-1.6 MeV Cosmic Ray Positrons", (with R. A. Mewaldt and E. C. Stone), ibid, 1, 401 (1975).
39. "The Quiet Time Spectra of Low Energy Hydrogen and Helium Nuclei", (with R. A. Mewaldt and E. C. Stone), ibid, 2, 774 (1975).
40. "Enrichment of Heavy Nuclei in ^3He Rich Flares", (with G. J. Hurford, R. A. Mewaldt, and E. C. Stone), Ap.J., 201, L95 (1975).
41. "Splash Albedo Protons Between 4 and 315 MeV at High and Low Geomagnetic Latitudes", (with K. P. Wenzel and E. C. Stone), J. Geophys. Res., 80, 3580 (1975).
42. "The Isotopic Composition of Hydrogen and Helium in Low Energy Cosmic Rays", (with R. A. Mewaldt and E. C. Stone), Ap.J., 206, 616 (1976).
43. "Observations of Jovian Electrons at 1 AU", (with R. A. Mewaldt and E. C. Stone), J. Geophys. Res. 81, 2397 (1976).
44. "Isotopic and Elemental Composition of the Anomalous Low Energy Cosmic Ray Fluxes", (with R. A. Mewaldt, E. C. Stone and S. B. Vidor), Ap.J. 205, 931 (1976).

PUBLICATIONS

RONALD WILLIAM PREST DREVER

1. Drever, R.W.P., Moljk, A., "K-capture in the decay of Chlorine-36", *Phil. Mag.* **46**, (7th S.), 1336 (1955).
2. Moljk, A., Drever, R.W.P., Curran, S.C., "Neutron activation applied to Potassium-mineral dating", *Rev. Sci. Inst.* **26**, 1034 (1955).
3. Drever, R.W.P., Moljk, A., "Measurement of Tritium as water vapour", *Rev. Sci. Inst.* **27**, 650 (1956).
4. Drever, R.W.P., Moljk, A., Curran, S.C., "Ratio of K-capture to positron emission in Flourine-18", *Nucl. Inst. and Meth.* **1**, 41 (1957).
5. Drever, R.W.P., Moljk, A., "L/K capture ratio of Germanium-71", *Phil. Mag.* **2**, (8th S.), 427 (1957).
6. Moljk, A., Drever, R.W.P., "Proportional counters for demonstration experiments", *Amer. J. Phys.* **25**, 165 (1957).
7. Moljk, A., Drever, R.W.P., Curran, S.C., "The background of counters and radiocarbon dating", *Proc. Roy. Soc.* **A239**, 433 (1957).
8. Drever, R.W.P., "Studies of orbital electron capture using proportional counters", Ph.D. Thesis, University of Glasgow (1958).
9. Moljk, A., Drever, R.W.P., Curran, S.C., "Proportional counters for low activity measurements", (*Proceedings of the 1st UNESCO International Conference, Paris, 1957*), *Radioisotopes in Scientific Research*, Vol. II, 596 (Pergamon Press, 1958).
10. Drever, R.W.P., "Upper limit to anisotropy of inertial mass", *Phil. Mag.* **5**, (8th S.), 409 (1960).
11. Drever, R.W.P., "A search for anisotropy of inertial mass using a free precession technique", *Phil. Mag.* **6**, (8th S.), 683 (1961).
12. Pound, R.V., Benedek, G.B., Drever, R.W.P., "Effect of hydrostatic compression on the 14.4 keV gamma ray from Iron-57", *Phys. Rev. Lett.* **7**, 405 (1961).
13. Dougan, P.W., Ledingham, K.W.D., Drever, R.W.P., "The L/K capture ratio of Argon-37", *Phil. Mag.* **7**, (8th S.), 475 (1962).
14. Dougan, P.W., Ledingham, K.W.D., Drever, R.W.P., "The decay of Chlorine-36 to Sulphur-36", *Phil. Mag.* **7**, (8th S.), 1223 (1962).
15. Ledingham, K.W.D., Payne, J.A., Drever, R.W.P., "The ratio of K-capture to positron emission in the decay of Nitrogen-13", *Proceedings of the International Conference on Role of Atomic Electrons in Nuclear Transformations*, Warsaw, 1963, Vol. II, 359 (ed. D. Berenyi) (1956).

58. "High Resolution Measurements of Galactic Cosmic Ray Neon, Magnesium and Silicon Isotopes", (with R.A. Mewaldt, J.D. Spalding and E.C. Stone), Ap.J. (Letters) 235, L95 (1980).
59. "The Isotopic Composition of Galactic Cosmic Ray Iron Nuclei", (with R.A. Mewaldt, J.D. Spalding and E.C. Stone), Ap.J. (Letters) 236, L121 (1980).
60. "Elemental Composition of Solar Energetic Nuclei", (with W.R. Cook and E.C. Stone), Ap.J. (Letters) 238, L97 (1980).
61. "The Isotopic Composition of Solar Flare Accelerated Magnesium", (with R.A. Mewaldt, J.D. Spalding, and E.C. Stone), Ap.J. (Letters) 243, L163 (1981).
62. "Energetic Charged Particles in Saturn's Magnetosphere: Voyager 1 Results", (with D.L. Chenette, A.C. Cummings, T.L. Garrard, E.C. Stone, A.W. Schardt, J.H. Trainor, N. Lal, and F.B. McDonald), Science 212, 231 (1981).
63. "High Resolution Measurements of Solar Flare Isotopes", (with R.A. Mewaldt, J.D. Spalding, and E.C. Stone), 17th International Cosmic Ray Conference, Paris, France, Conf. Papers 3, 131 (1981).
64. "The Isotopic Composition of Low Energy Cosmic Rays", (with R.A. Mewaldt, J.D. Spalding, and E.C. Stone), *ibid* 2, 68 (1981). Erratum, *ibid* 11, 431 (1981).
65. "The Isotopic Composition of Cosmic Ray B, C, N, and O Nuclei", (with R.A. Mewaldt, J.D. Spalding, and E.C. Stone), Ap.J. (Letters) 251, L27 (1981).
66. "Energetic Charged Particles in Saturn's Magnetosphere: Voyager 2 Results", (with D.L. Chenette, A.C. Cummings, T.L. Garrard, E.C. Stone, A.W. Schardt, J.H. Trainor, N. Lal, and F.B. McDonald), Science 215, 577 (1982).
67. "Elemental Composition of Solar Energetic Particles" (with W.R. Cook and E.C. Stone), Ap. J. 279, 827 (1984)

ments", *Proceedings of the 6th Texas Symposium on Relativistic Astrophysics*, Ann. New York Acad. Sci. **224**, 103 (ed. J.H. Hegyi), (1973).

29. Drever, R.W.P., "Weber's Waves", *Nature* **243**, 553 (1973).
30. Drever, R.W.P., Hough, J., Bland, R., Lessnoff, G.W., "Search for short bursts of gravitational radiation", *Nature* **246**, 340 (1973).
31. Jelley, J.V. (Harwell); Meikle, W.P.S., Drever, R.W.P. (Glasgow); Palumbo, G.G.C., Bonoli, F. (Bologna); Smith, H., Delaney, T. (Dublin), "An experiment to search for prompt emissions from supernovae at microwave frequencies", *Proceeding of the International Conference on Supernovae and Supernovae Remnants*, (Lecce, May, 1973), (ed. C.G. Cosmovici), **61**, (D. Reidel Publishing Co., 1974).
32. Drever, R.W.P., Hough, J., Bland, R., Lessnoff, G.W., Colloques, "Experiments and observations with wide band gravity-wave detectors", *Internationaux du Centre National de la Recherche Scientifique (Ondes et Radiations Gravitationnelles, June, 1973): CNRS Report 220*, 113 (ed. Y. Choquet-Bruhat) (Paris, 1974).
33. Drever, R.W.P., "Gravitational-wave experiments", *Proceedings of the 1973 School for Young High Energy Physicists, Rutherford Laboratory* (ed. H. Muirhead). Rutherford Lab. Report RL-74-038, VIII-1 (1974).
34. Drever, R.W.P., Meikle, W.P.S., Hough, J., Bland, R., Lessnoff, G.W. (Glasgow); in association with Jelley, J.V. (Harwell); Delaney, T. (Dublin); Palumbo, G.G.C. (Bologna), "Searches for ionospheric effects of X-ray bursts, and for bursts of radio emission, gravitational radiation and microwave emission from astronomical sources", *Proceedings of the Conference on Transient Cosmic Gamma and X-ray Sources*, (Los Alamos, September, 1978), (ed. I. Strong), LA-5505-C Conference Proceedings UC-34B (1974).
35. Delaney, T., Baird, G.A., Smith, H. (Dublin); Jelley, J.V., Fruin, J.H. (Harwell); Meikle, W.P.S., Drever, R.W.P. (Glasgow); Morigi, G., Palumbo, G.G.C. (Bologna); Partridge, R.G. (Haverford, USA), "A search for isolated microwave pulses from the Perseus Clusters of Galaxies", *Astronomy and Astrophysics* **36**, 83 (1974).
36. Drever, R.W.P., "Contribution to panel discussion on gravitational-waves", *Proceedings of the 7th International Conference on General Relativity and Gravitation*, (Tel-Aviv, June 1974) (ed. G. Shaviv and J. Rosen; Halsted Press - John Wiley), 243-298 (1975).
37. Baird, G.A., Delaney, T., Lawless, B.F. (Dublin); Griffiths, D.J., Shakeshaft, J.R. (Cambridge); Drever, R.W.P., Meikle, W.P.S. (Glasgow); Jelley, J.V., Charman, W.N. (Harwell), "A search for VHF radio pulses in coincidence with celestial gamma-ray bursts", *Astrophysics J. Lett.* **196**, L11 (1975).
38. Hough, J., Pugh, J.R., Bland, R., Drever, R.W.P., "Search for continuous gravitational radiation", *Nature* **254**, 498 (1975).
39. Meikle, W.P.S., Drever, R.W.P. (Glasgow); Baird, G.A., Delaney, T. (Dublin); Jel-

16. Charman, W.N., Jelley, J.V., Orman, P.R., Drever, R.W.P., McBreen, B., "Search for high energy gamma-rays from pulsar CP 1133", *Nature*, **220**, 565 (1968).
17. Drever, R.W.P., Williams, M.D.C., "A technique for removing pile-up distortion in high precision pulse height spectroscopy", *Proceedings of the International Symposium on Nuclear Electronics*, Versailles (1968).
18. Charman, W.N., Drever, R.W.P., "Further search for high energy gamma-rays from CP 1133", *Nature* **224**, 567 (1969).
19. Charman, W.N., Jelley, J.V., Drever, R.W.P., "A search for periodic high energy gamma rays from pulsars", *Proceedings of the 11th International Conference on Cosmic Rays*, Budapest, 1969; *Act Phys. Acad. Sci. Hungar.* **29**, Suppl., **1**, 63 (1970).
20. Campbell, J.L., Leiper, W., Ledingham, K.W.D., Drever, R.W.P., "The ratio of K-capture to positron emission in the decay of Carbon-11", *Nucl. Phys.* **A96**, 279 (1967).
21. Charman, W.N., Drever, R.W.P., Fruin, J.H., Jelley, J.V., "Upper-air fluorescence as a tool in X-ray astronomy and searches for X-rays from CP 0532 and other pulsars", in *Non solar X- and gamma-ray astronomy*, (ed. L. Gratton), (Int. Astron. Union, 1970).
22. Charman, W.N., Jelley, J.V., Fruin, J.H. (Atomic Energy Research Establishment, Harwell); Hodgson, E.R., Scott, P.F., Shakeshaft, J.R. (Mullard Radio Astronomy Observatory, University of Cambridge); Baird, G.A., Delaney, T., Lawless, B.G. (University College, Dublin); Drever, R.W.P., Meikle, W.P.S. (University of Glasgow); Porter, R.A., Spencer, R.E. (Nuffield Radio Astronomy Laboratories, Jodrell Bank, University of Manchester), "Spaced receiver observations of radio pulses", *Nature*, **228**, 346 (1970).
23. Charman, W.N., Fruin, J.H., Jelley, J.V. (Harwell); Haynes, R.F., Hodgson, E.R., Scott, P.F., Shakeshaft, J.R. (Cambridge); Baird, G.A., Delaney, T., Lawless, B.F. (Dublin and Malta); Drever, R.W.P., Meikle, W.P.S. (Glasgow), "A search for isolated radio pulses from the Galactic Centre at 151.5 MHz.", *Nature* **232**, 177 (1971).
24. Drever, R.W.P., Fruin, J.H., Jelley, J.V., "A precision sidereal telescope drive", *Observatory* **91**, 203 (1971).
25. Leiper, W., Drever, R.W.P., "K-electron capture to positron emission ratio in the decays of Oxygen-15 and Neon-19", *Phys. Rev.* **C6**, 1132 (1972).
26. Meikle, W.P.S., Drever, R.W.P. (Glasgow); Haynes, R.F., Shakeshaft, J.R. (Cambridge); Charman, W.N., Jelley, J.V. (Harwell), "A search for isolated radio pulses from the Crab Nebula at 151.5 MHz.", *Mon. Not. Astro. Soc.* **160**, 50 (1972).
27. Hough, J., Drever, R.W.P., "Proportional counters for the localization of ionizing radiation", *Nucl. Instr. and Meth.* **103**, 365 (1972).
28. Drever, R.W.P., "Contribution to open discussion on gravitational radiation experi-

51. Drever, R.W.P., "The search for gravitational-waves", *Engineering and Science*, 6-9; 24-26 (Caltech, 1983).
52. Drever, R.W.P., Hough, J., Munley, A.J., Lee, S.-A., Spero, R., Whitcomb, S.E., Pugh, J., Newton, G., Meers, B., Brooks III, E., Gürsel, Y., "Gravitational-wave detectors using laser-interferometers and optical cavities: 1. Ideas, Principles, and Prospects", in *Quantum Optics, Experimental Gravity, and Measurement Theory* (eds. Pierre Meystere and Marlan O. Scully), 503-514 (Plenum Publishing, 1983).
53. Hough, J., Drever, R.W.P., Munley, A.J., Lee, S.-A., Spero, R., Whitcomb, S.E., Pugh, J., Newton, G., Meers, B., Brooks III, E., Gürsel, Y., "Gravitational-wave detectors using laser-interferometers and optical cavities: 2. Some practical aspects and results", in *Quantum Optics, Experimental Gravity, and Measurement Theory* (eds. Pierre Meystere and Marlan O. Scully), 515-524 (Plenum Publishing, 1983).
54. Drever, R.W.P., "Contribution on the millisecond pulsar", *Proceedings of the Meeting of the Royal Astronomical Society, (December, 1982), The Observatory*, 103, 118 (June 1983).
55. Drever, R.W.P., Hall, J.L., Kowalski, F.V., Hough, J., Ford, G.M., Munley, A.J., Ward, H., "Laser phase and frequency stabilization using an optical resonator", *Applied Physics*, B31, 97-103 (1983).
56. Drever, R.W.P., Ford, G., Hough, J., Kerr, I., Munley, A.J., Pugh, J., Robertson, N., Ward, H., "A gravity-wave detector using optical cavity sensing", *Proceedings of the 9th International Conference on General Relativity and Gravitation, 1981*, (ed. E. Schmutzer), 265-267, (Veb Deutscher Verlag der Wissenschaften, DDR-1080, Berlin, 1983).
57. Hough, J., Drever, R.W.P., Ward, H., Munley, A.J., Newton, G., Meers, B., Hoggan, S., Kerr, G.A., "Direct observational upper limit to gravitational radiation from millisecond pulsar PSR 1937 + 214", *Nature*, 303, (5941), 216-217 (May, 1983).
58. Whitcomb, S.E., Anderson, D.Z., Drever, R.W.P., Gürsel, Y., Hereld, M., Spero, R., "Laser-interferometer experiments at Caltech", *Proceedings of the Third Marcel Grossman Conference on General Relativity*, (Shanghai, China 1982), (ed. Hu Ning) (Science Press and North-Holland Publishing Co.), 1399 (1983).
59. Drever, R.W.P., Hoggan, S., Hough, J., Meers, B.J., Munley, A.J., Newton, G.P., Ward, H., Anderson, D.Z., Gürsel, Y., Hereld, M., Spero, R., Whitcomb, S.E., "Developments in laser-interferometer gravitational-wave detectors", *Proceedings of the Third Marcel Grossman Conference on General Relativity*, (Shanghai, China 1982), (ed. Hu Ning) (Science Press and North-Holland Publishing Co.), 739-753 (1983).
60. Spero, R., Anderson, D.Z., Drever, R.W.P., Gürsel, Y., Gutt, G., Hereld, M., Kaufman, K., Whitcomb, S.E., "The Caltech gravitational-wave detector", in *General Relativity and Gravitation, Proceedings of the 10th International Conference on General Relativity and Gravitation*, (Padua, July 1983), (eds. B. Bertotti, F. de Felice, and A. Pascolini; Reidel Pub. Co.), 930-932 (1984).

- ley, J.V., Fruin, J.H. (Harwell); Palumbo, G.G.C., Morigi, G. (Bologna); Partridge, R.B. (Haverford, USA), "An upper limit to microwave pulse emission at the onset of a supernova", *Astronomy and Astrophysics* **46**, 477 (1976).
40. Drever, R.W.P., "Gravitational-wave astronomy", *Quarterly J. Roy. Astr. Soc.* **18**, 9 (1977).
 41. Drever, R.W.P., Hough, J., Edelstein, W., Martin, W., "Gravitational-wave detectors using optical interferometry", *Gravitazione Sperimentale, (Accademia Nazionale dei Lincei, Rome)* (ed. B. Bertotti) 365 (1977).
 42. Palumbo, G.G.C., Mandolesi, N., Morigi, G. (Bologna); Baird, G.A., Delaney, T. (Dulin); Meikle, W.P.S., Drever, R.W.P. (Glasgow); Jelley, J.V., Fruin, J.H. (Harwell); Partridge, B. (Haverford USA), "Upper limits for the microwave pulsed emission from supernova explosions in clusters of galaxies", *Astrophysics Space Science*, **54**, 355 (1978).
 43. Hough, J., Drever, R.W.P., "Gravity-wave detection: a tough challenge", *New Scientist*, **79**, 464 (1978).
 44. Thorne, K.S., Drever, R.W.P., Caves, C.M., Zimmermann, M., Sandberg, V.D., "Quantum nondemolition measurements of harmonic oscillators", *Phys. Rev. Lett.* **40**, 667 (1978).
 45. Thorne, K.S., Caves, C.M., Sandberg, V.D., Zimmermann, M., Drever, R.W.P., "The quantum limit for gravitational wave detectors and methods of circumventing it", *Sources of Gravitational Radiation*, (ed. L. Smarr) (Cambridge University Press), 49 (1979).
 46. Caves, C.M., Drever, R.W.P., Sandberg, V.D., Thorne, K.S., Zimmermann, M., "On the measurement of a weak classical force coupled to a quantum mechanical oscillator", *Rev. Mod. Phys.* **52**, (2), 341 (1980).
 47. Drever, R.W.P., Hough, J., Munley, A.J., Lee, S.-A., Spero, R., Whitcomb, S.E., Ward, H., Ford, G.M., Hereld, M., Robertson, N.A., Kerr, I., Pugh, I., Newton, G.P., Meers, B., Brooks, E.D., Gürsel, Y., "Optical cavity laser-interferometers for gravitational wave detection", *Proceedings of the 5th International Conference on Laser Spectroscopy (VICOLS)*, Jasper, Canada, **33**, (Springer-Verlag, 1981).
 48. Drever, R.W.P., "Interferometric detectors for gravitational radiation", *Gravitational Radiation*, NATO Advanced Physics Institute, Les Houches, (ed. N. Deruelle and T. Piran), 321-337, (North Holland Publishing, 1983).
 49. Drever, R.W.P., "Laser-interferometer gravitational radiation detectors", *Science Underground, American Institute of Physics*, Conference Proceedings No. 96, 336-346 (Los Alamos, 1982).
 50. Robertson, N.A., Drever, R.W.P., Kerr, I., Hough, J., "Passive and active isolation for gravitational radiation detectors and other instruments", *Phys. E. Sci. Instr.* **15**, 1101-1105 (1982).

Kip S. Thorne – Partial List of Publications

A. Technical Books Co-authored

- B. K. Harrison, K. S. Thorne, M. Wakano, and J. A. Wheeler, *Gravitation Theory and Gravitational Collapse* (University of Chicago Press, Chicago, 1965) 177 pp.
- A. G. W. Cameron and K. S. Thorne, *High Energy Astrophysics*, Vol. 3, eds. C. DeWitt, E. Schatzman, P. Veron (Gordon and Breach, New York, 1967) 449 pp.
- C. W. Misner, K. S. Thorne, and J. A. Wheeler, *Gravitation*, (W. H. Freeman & Co., San Francisco, 1973) 1279 pp.
- K. S. Thorne, R. H. Price, and D. M. Macdonald, *Black Holes: The Membrane Paradigm* (Yale University Press, New Haven, Conn., 1986), 367 pp.

B. Selected Publications on Gravitational Radiation

- K. S. Thorne, "Gravitational Radiation Damping", *Physical Review Letters*, **21**, 320–323 (1968).
- K. S. Thorne, "Nonradial Pulsation of General Relativistic Stellar Models. III. Analytic and Numerical Results for Neutron Stars", *Astrophysical Journal*, **158**, 1–16 (1969).
- W. H. Press and K. S. Thorne, "Gravitational-Wave Astronomy", *Annual Review of Astronomy and Astrophysics*, **10**, 335–374 (1972).
- K. S. Thorne, "How to Test Gravitation Theories by Means of Gravitational-Wave Measurements" in *Colloque International C.N.R.S. No. 220, "Ondes et Radiations Gravitationnelles"*, (Institut Henri Poincaré, Paris, 1974) pp. 214–223.
- K. S. Thorne and S. Kovacs, "The Generation of Gravitational Waves. I. Weak-Field Sources", *Astrophysical Journal*, **200**, 245–262 (1975).
- K. S. Thorne and V. B. Braginsky, "Gravitational-Wave Bursts from the Nuclei of Distant Galaxies and Quasars: Proposal for Detection Using Doppler Tracking of Interplanetary Spacecraft", *Astrophysical Journal*, **204**, L1–L6 (1976).
- H. D. Wahlquist, J. D. Anderson, F. B. Estabrook, and K. S. Thorne, "Recent JPL Work on Gravity Wave Detection and Solar System Relativity Experiments", in *Gravitatione Sperimentale*, Proceedings of September 1976 Pavia Conference, ed. B. Bertotti (Rome: Accademia Nazionale dei Lincei, 1977) pp. 335–350.
- S. Kovacs and K. S. Thorne, "The Generation of Gravitational Waves. IV. Bremsstrahlung" *Astrophysical Journal*, **222**, 62–85 (1978).
- K. S. Thorne, "The Generation of Gravitational Waves: A Review of Computational Techniques", in *Topics in Theoretical and Experimental Gravitation Physics*, eds. V. De Sabbata and J. Weber (Plenum Press, New York and London, 1977) pp. 1–61.
- K. S. Thorne, R. W. P. Drever, C. M. Caves, M. Zimmermann, and V. D. Sandberg, "Quantum Nondemolition Measurements of Harmonic Oscillators", *Physical Review Letters*, **40**, 667–671 (1978).

61. Ward, H., Drever, R.W.P., Hough, J., Munley, A.J., Newton, G.P., Meers, B.J., Hoggan, S., Kerr, G.A., "Development of a long baseline laser interferometer gravitational radiation detectors using resonant optical cavities", in *General Relativity and Gravitation, Proceedings of the 10th International Conference on General Relativity and Gravitation*, (Padua, July 1983), (eds. B. Bertotti, F. de Felice, and A. Pascolini; Reidel Pub. Co.) 939-941 (1984).
62. Chen, Y-T., Drever, R.W.P., "Reduction of seismic noise in a laser gravitational wave detector by interferometer control of test mass suspension points", Prepared for the *Proceedings of the International Symposium on Experimental Gravitational Physics*, (Guangzhou, P. R. China, August 3-8, 1987).
63. Drever, R.W.P., Spero, R., Chen, Y-T., Čade ž, A., Abramovici, A., Gürsel, Y., Zucker, M.E., Smith, S., Bostick, A., Ward, H., "Developments in laser interferometer gravity wave detectors", In preparation for the *Proceedings of the International Symposium on Experimental Gravitational Physics*, (Guangzhou, P. R. China, August 3-8, 1987).

Rainer Weiss

Publications List:

- "Magnetic Moments and Hyperfine Structure Anomalies of Cs¹³³, Cs¹³⁵, and Cs¹³⁷," Phys. Rev. 105, 590 (1957), with H.H. Stroke, V. Jaccarino, and D.S. Edmonds.
- "Molecular Beam Electron Bombardment Detector," Rev. Sci. Instr. 32, 397 (1961).
- "A Search for a frequency Shift of 14.4 KeV Photons on Traversing Radiation Fields," Physics Letters 1, 342 (1962), with L. Grodzins.
- "Stark Effect and Hyperfine Structure of Hydrogen Fluoride," Phys. Rev. 131, 659 (1963).
- "The Cesium Fountain Experiment: The Paucity of Slow Atoms," Festschrift, (1965), for J.R. Zacharias.
- "A Gravimeter to Monitor the \circ S₀ Dilational Mode of the Earth," J. Geophys. Res. 70, 5615 (1966), with B. Block.
- "Experimental Test of the Freundlich Red-Shift Hypothesis," Phys. Rev. 155, 1412 (1967), with G. Blum.
- "Electric and Magnetic Field Probes," A J. Phys. 35, 1047 (1967).
- "Laser-induced Fluorescence in a Molecular Beam of Iodine," Phys. Rev. Let. 20, 91 (1968), with S. Ezekiel.
- "A Measurement of the Isotropic Background Radiation in the Far Infrared," Phys. Rev. Let. 24, 742 (1970), with D. Muehlner.
- "Electromagnetically Coupled Broadband Gravitational Antenna," Quarterly Progress Report, Research Lab. of Electronics, M.I.T., 105, 54 (1972).
- "Balloon Measurements of the Far Infrared Background Radiation," Phys. Rev. D 7, 326 (1973), with D. Muehlner.
- "Further Measurements of the Submillimeter Background at Balloon Altitude," Phys. Rev. Let. 30, 757 (1973), With D. Muehlner.
- "Measurements of the Phase Fluctuations in a He-Ne Zeeman Laser," Rev. Sci. Instr. 45, 1060 (1974), with D.K. Ownes.
- "The Oldest Fossil," Technology Review 78, P 56 (1975).
- "A Large Beam Sky Survey at Millimeter and Submillimeter Wavelengths made from Balloon Altitudes," Astrophysical Journal 231, 702 (1979) with D. Owens and D. Muehlner.

- K. S. Thorne, C. M. Caves, V. D. Sandberg, M. Zimmermann, and R. W. P. Drever, "The Quantum Limit for Gravitational-Wave Detectors and Methods of Circumventing It", in *Sources of Gravitational Radiation*, ed. L. Smarr (Cambridge: Cambridge University Press, 1979) pp. 49-68.
- V. D. Braginsky, Yu. I. Vorontsov, and K. S. Thorne, "Quantum Non-demolition Measurements", *Science*, **209**, 547-557 (1980). Reprinted as Chapter VI.8 of "Quantum Theory and Measurement", ed. J. A. Wheeler and W. H. Zurek (Princeton University Press, Princeton, NJ, 1983) pp. 749-768.
- C. M. Caves, K. S. Thorne, R. W. P. Drever, V. D. Sandberg, and M. Zimmermann, "On the Measurement of a Weak Classical Force Coupled to a Quantum-Mechanical Oscillator. I. Issues of Principle", *Reviews of Modern Physics*, **52**, 341-392 (1980).
- K. S. Thorne, "Multipole Expansion of Gravitational Radiation", *Reviews of Modern Physics*, **52**, 299-340 (1980).
- K. S. Thorne, "Gravitational-Wave Research: Current Status and Future Prospects", *Reviews of Modern Physics*, **52**, 285-298 (1980).
- M. Zimmermann and K. S. Thorne, "The Gravitational Waves that Bathe the Earth: Upper Limits Based on Theorists' Cherished Beliefs", in *Essays in General Relativity. A Festschrift for Abraham Taub*, ed. F. Tipler (Academic Press, New York, 1980) pp. 139-155.
- K. S. Thorne, "The Theory of Gravitational Radiation: An Introductory Review", in *Gravitational Radiation*, eds. N. Dereulle and T. Piran (North Holland, Amsterdam, 1983) pp. 1-57.
- V. B. Braginsky and K. S. Thorne, "Skyhook Gravitational Wave Detector", *Nature* **316**, 610-612 (1985).
- V. B. Braginsky and K. S. Thorne, "Gravitational-Wave Bursts with Memory and Experimental Prospects", *Nature* **327** 123-125 (1987).
- K. S. Thorne, "Gravitational Radiation", in *Three Hundred Years of Gravitation*, ed. S. W. Hawking and W. Israel (Cambridge: Cambridge University Press) pp. xx-xx.

"Gravitational Radiation - The Status of the Experiments and Prospects for the Future," in Sources of Gravitational Radiation, Cambridge University Press, Cambridge, England (1979).

"Monolithic Silicon Bolometers," Journal of Infrared and Millimeter Waves 1 (1980), with P.M. Downey, F.J. Bachner, J.P. Donnelly, W.T. Lindley, R.W. Mountain and D. J. Silversmith.

"Monolithic Silicon Bolometers," Applied Optics 23, 910 (1983), with P.M. Downey, A.D. Jeffries, S.S. Meyer, F.J. Bachner, J.P. Donnelly, W.R. Lindley, R.W. Mountain, D.J. Silversmith.

"Measurements of the Cosmic Background Radiation," Annual Review of Astronomy and Astrophysics 18, 489 (1980).

"The COBE Project," Physica Scripta 21, 670 (1980).

"A Search for the Sunyaev-Zel'dovich Effect at Millimeter Wavelengths," Ap. J. Let. 271 L1 (1983), with S.S. Meyer and A.D. Jeffries.

Reports:

"Study Report for the Cosmic Background Explorer," Goddard Space Flight Center, Feb. 1977, with S. Gulkis, M. Hauser, J. Mather, G. Smoot, D. Wilkinson.

"Report of the Sub-Panel on Relativity and Gravitation," Management and Operations Working Group for Shuttle Astronomy, NASA Headquarters, Sept., 1976, with P. Bender, C. Misner, R.V. Pound.

"Report of the Detector Study Panel NASA," with P. Richards (Chairman) 1979.

"A Study of a Long Baseline Gravitational Wave Antenna System," with P. Linsay and P. Saulson 1983.

"Task Group on Fundamental Physics and Chemistry" National Academy of Sciences Report on Gravitational Physics, 1987, with P. Bender, A. Berlad, R. Donnelly, F. Dyson, W. Fairbank, G. Homsy, J. Langer, J. Naugle, R. Pellat, J. Reynolds, R. Ruffini, D. Saville, J. Schrieffer.

Articles Submitted for Publication:

"Measurements of the Anisotropy of the Cosmic Background Radiation and Diffuse Galactic Emission at Millimeter and Submillimeter Wavelengths," with M. Halpern, R. Benford, S. Meyer, D. Muehlner.

Articles in Preparation:

"Noise Due to Scattered Light in Interferometric Gravitational Antennas and Its Reduction by Random Phase Modulation of the Input Beam," with D. Dewey and J. Livas.

"Analysis of a Multipass Interferometer Using Tagged Light Beams and a Compact Geometry for Gravitational Wave Research."

"Response of a Free Mass Interferometric Antenna to Gravitational Wave Excitation," with Y. Gursel, P. Linsay, R. Spero, P. Saulson and S. Whitcomb.